



ISO 9001-2008 Certified

MASCOT®

Radial Piston Hydraulic Motor



- ✓ LD Series
- ✓ MD Series
- ✓ MDS Series
- ✓ 820 Series
- ✓ HD Series



MD series

MASCOT MD Series Hydraulic Motors are designed for high power and high speed applications. Most of the Wagon Tippler, Slew drive are driven by MD Series motors. In addition, these motors are most suited for use in Feeder Breaker, Ball Mills and Bowl Mills. Optionally, a brake can be fitted in the front end of the motor.

The motor displacements available range from 12 lit/rev. to 15 lit/rev. They aim to provide a wide variety of precise hydraulic motor and pump combinations. These motors can take heavy shock loads due to the incorporation of a robust front bearing arrangement.

Options

- ✓ Customized shaft
- ✓ Integral multi plate disc brake
- ✓ High speed versions
- ✓ Double shaft
- ✓ Super low noise
- ✓ Corrosion resistant material
- ✓ Through hole shaft of various sizes
- ✓ Custom finish
- ✓ Deep water submersible
- ✓ Non magnetic material
- ✓ Dual displacement

Features

- ✓ Long life
- ✓ High mechanical efficiency
- ✓ Constant torque output
- ✓ Smooth low speed performance < 1rpm
- ✓ Resistance to thermal shock
- ✓ Double shaft sealing
- ✓ Shrink disc coupling
- ✓ Shaft or flange mounting
- ✓ Shock resistance
- ✓ Low noise

MOTOR FRAME SIZE	SPECIFICATION					
	DISP(*) PER REV	TORQUE (THEORETICAL)	TORQUE MAX	SPEED RATED	SPEED MAX**	PRESSURE RATED
METRIC	CM ³ /REV	NM/BAR	NM	RPM	RPM	BAR
HM 12	12760	200	66000	75	100	345
HM 13.5	13540	215	70950	75	110	345
HM 15	15160	241	79530	70	100	345

**High speed version upon request.

* Any other displacement upon request.

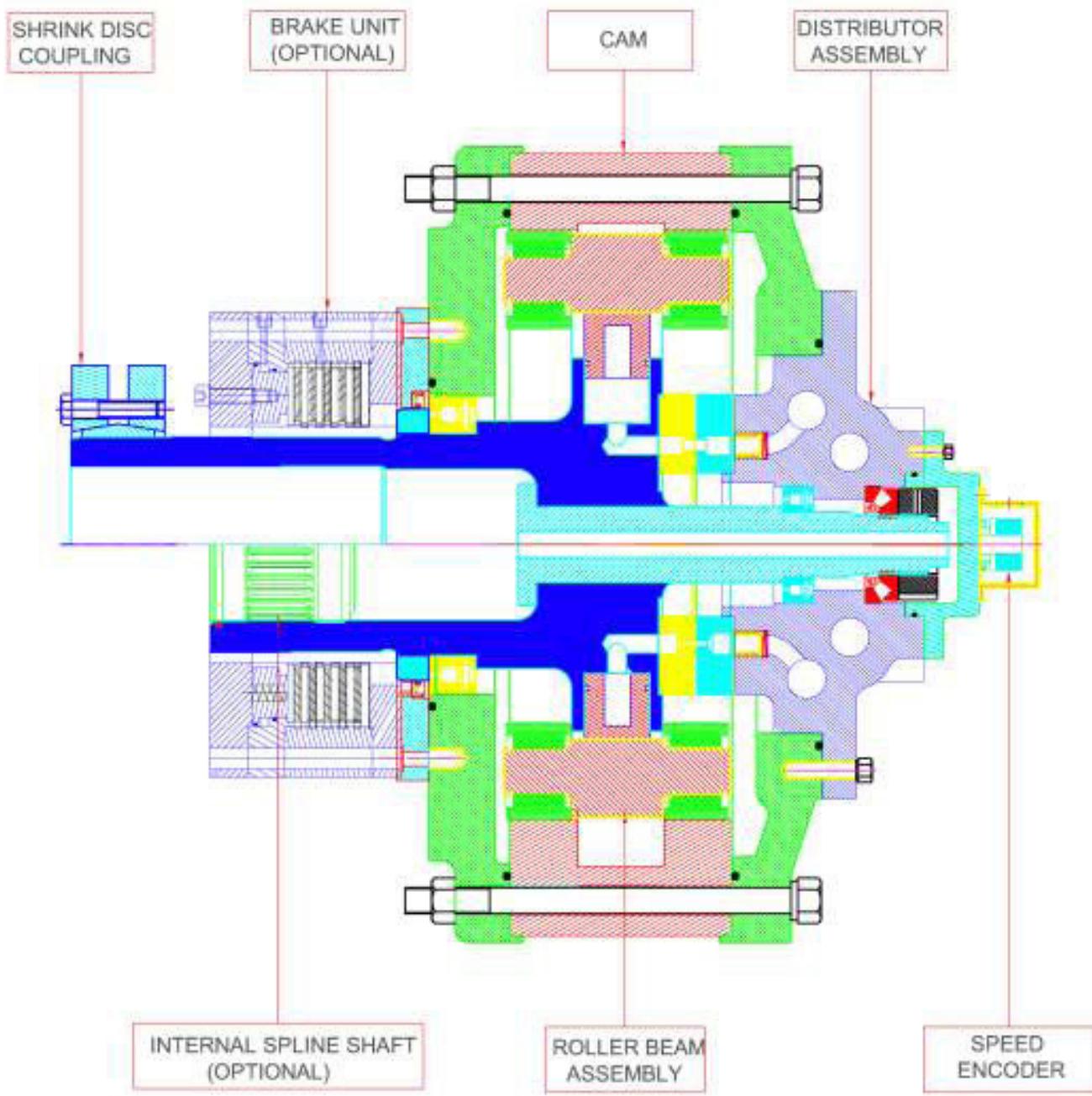

MECHANICAL EFFICIENCY, η_m

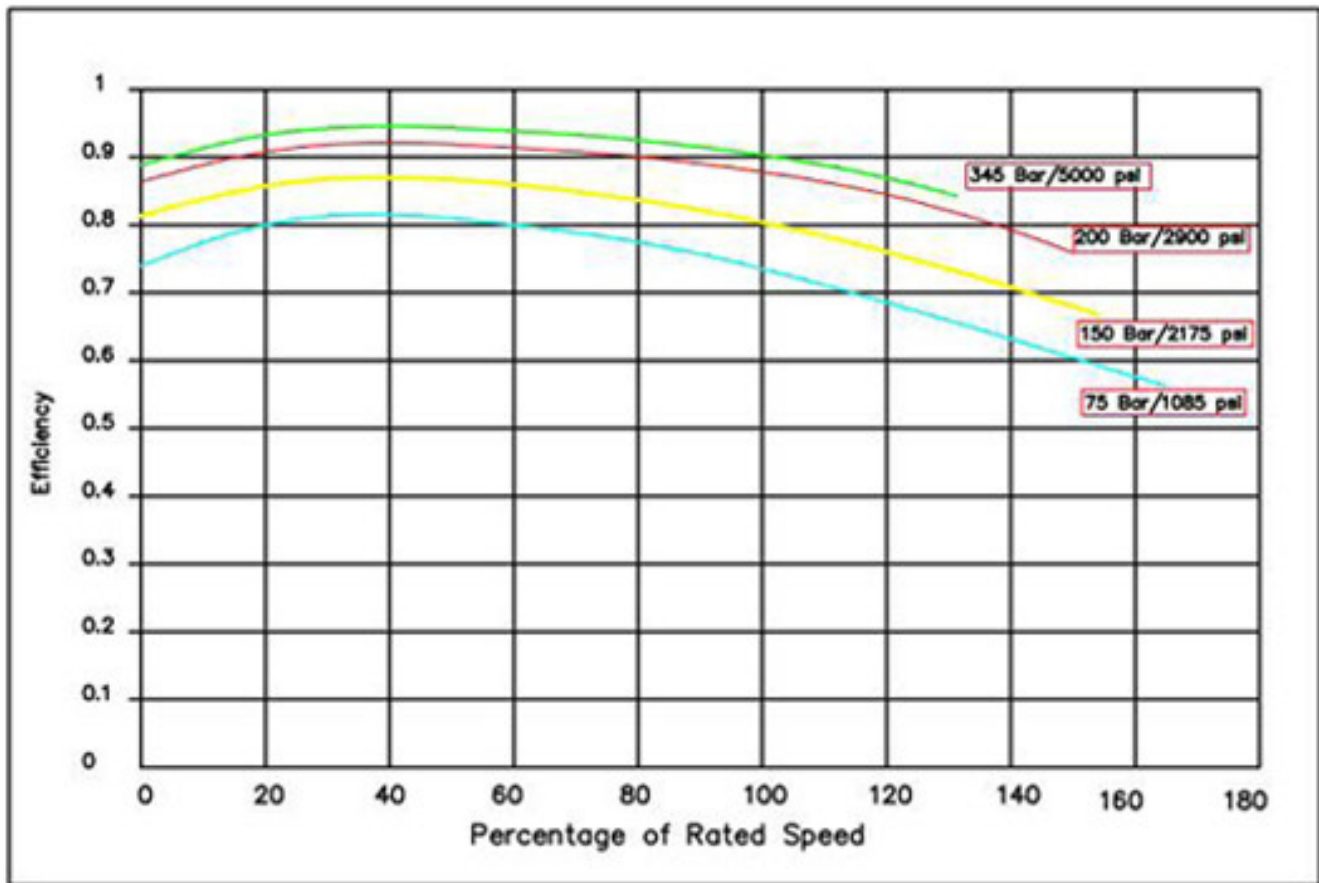

Starting Torque Efficiency should be taken as 0.86

RECOMMENDED CHARGE PRESSURE, P_c

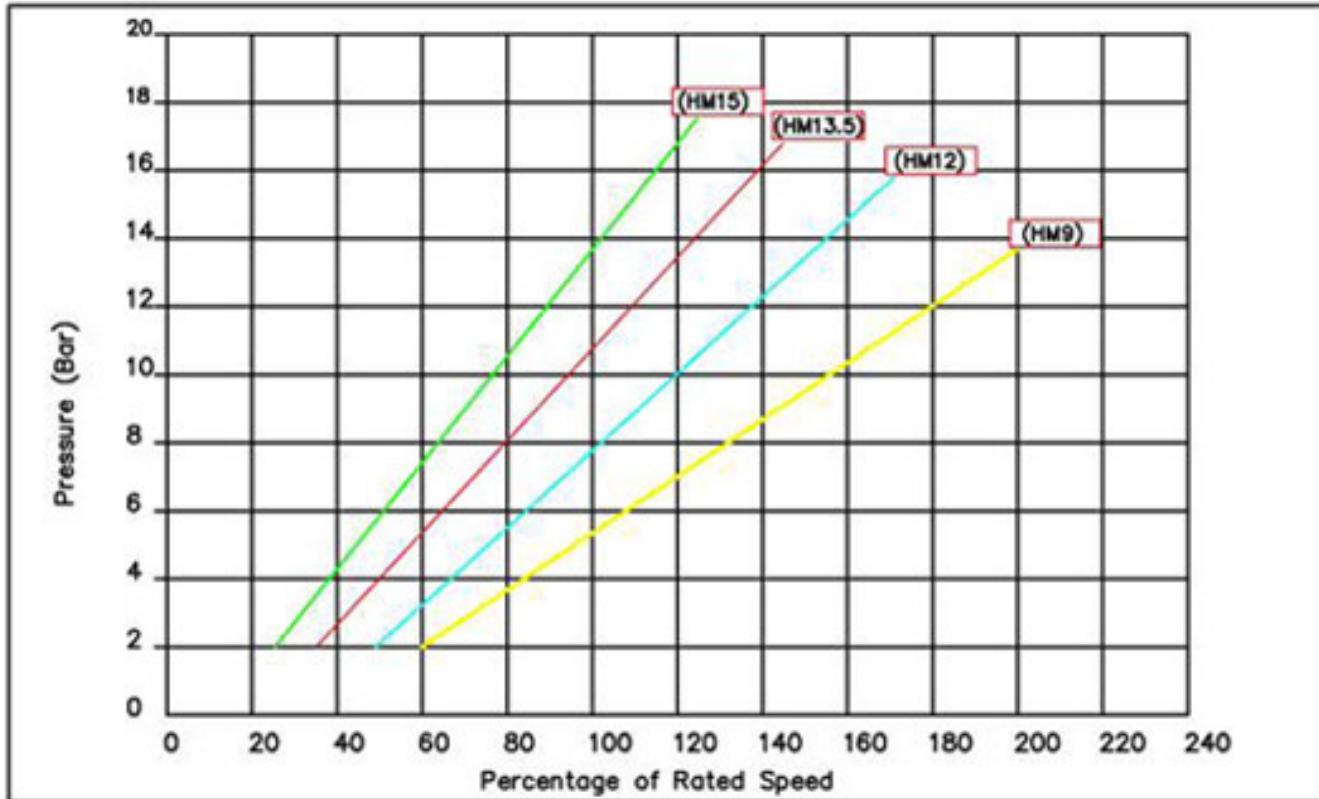

VOLUMETRIC LOSS, QL AT 20° (50cSt)

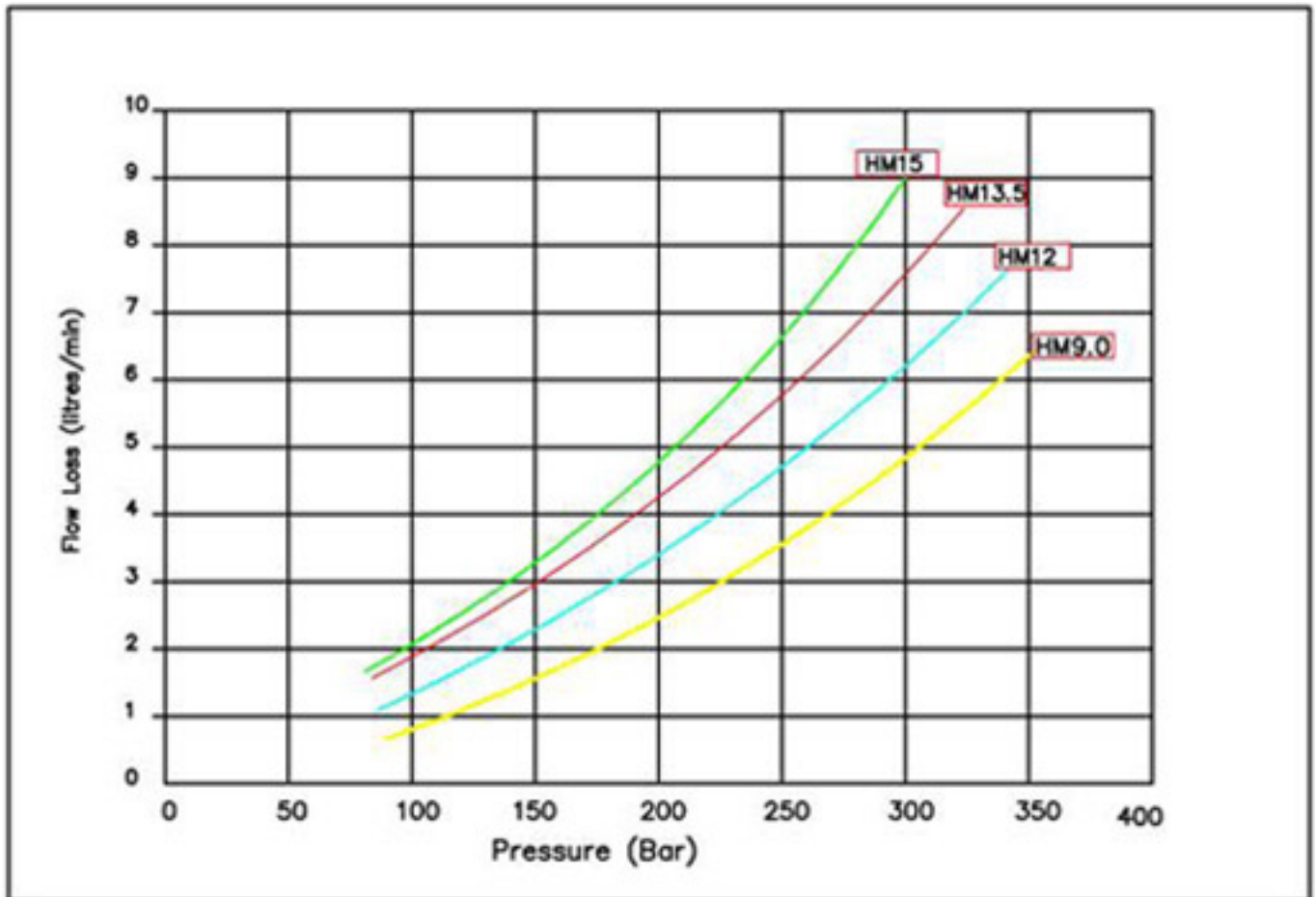

MD series

Motors with shrink disc coupling

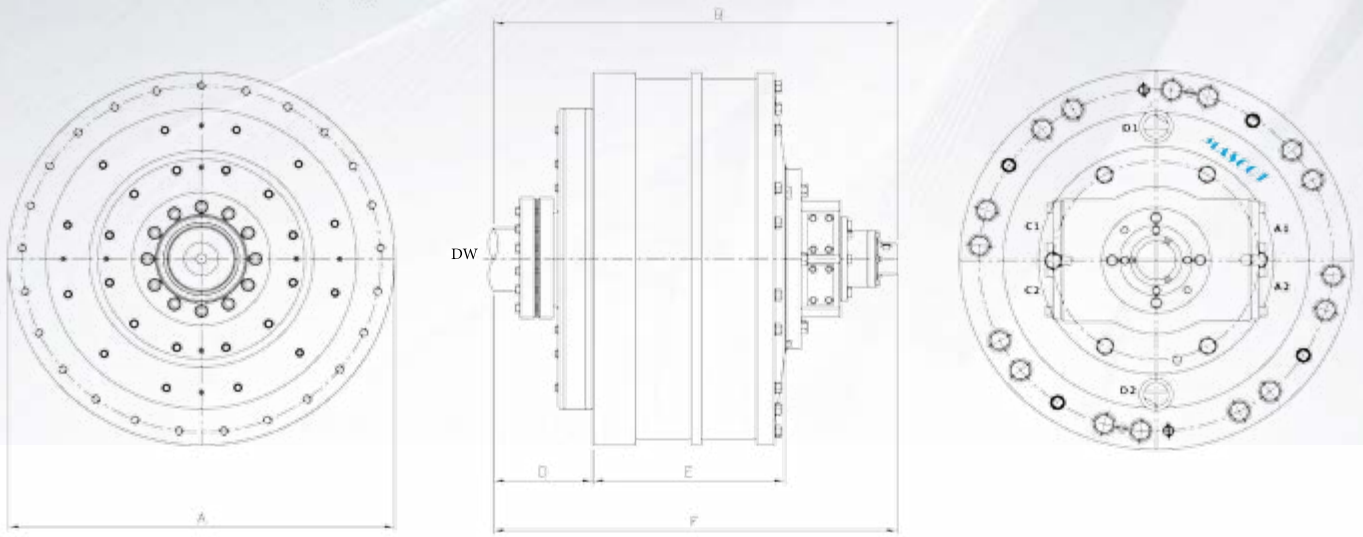

Hollow shaft motors with female splines

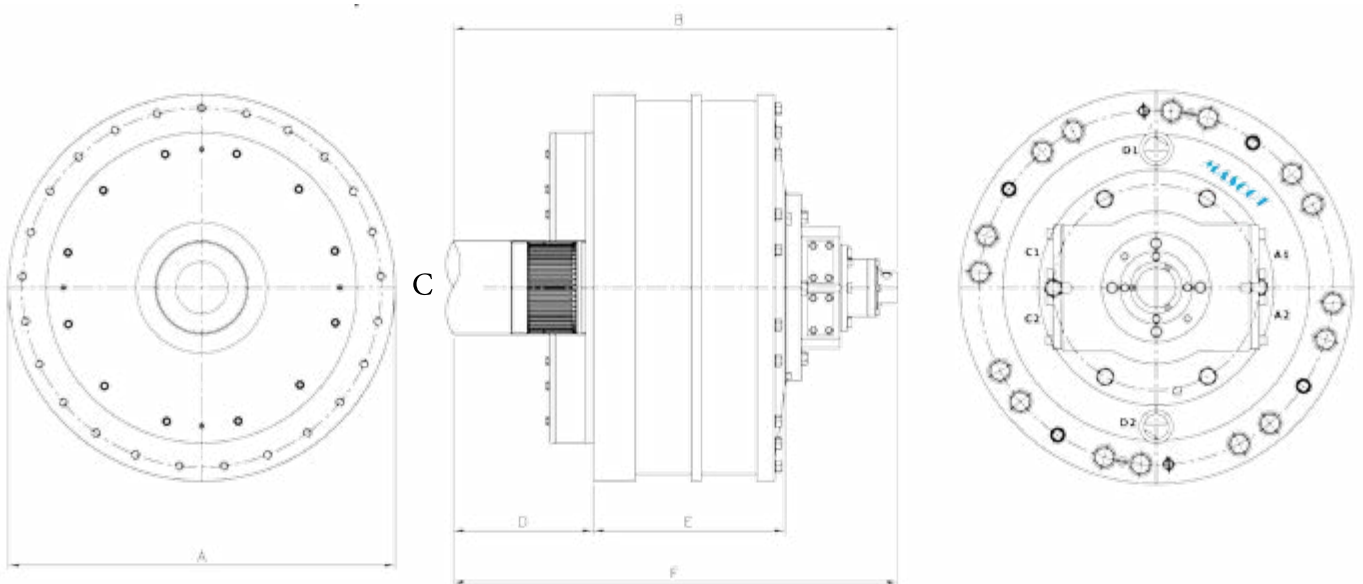

MD series

Motors with shrink disc coupling

Motor Type	A(MM)	B(MM)	DW(MM)	E(MM)	F(MM)	G(MM)	Weight (Kg)	Main Connc (A1,A2,C1,C2)	Drain Connc (D1,D2)
HM 12.0	650	994	160	321	520	962	693	SAE 1 1/4"	BSP 3/4"
HM 13.0	650	994	160	321	520	962	697	SAE 1 1/4"	BSP 3/4"
HM 15.0	650	1062	180	390	520	1032	724	SAE 1 1/4"	BSP 3/4"

Hollow shaft motors with female splines

Motor Type	A(MM)	B(MM)	C(MM)	D(MM)	E(MM)	F(MM)	Weight (Kg)	Main Connc (A1,A2,C1,C2)	Drain Connc (D1,D2)
HM 12.0	650	933	N150x5x30x28x9H	260	520	893	627	SAE 1 1/4"	BSP 3/4"
HM 13.5	650	933	N150x5x30x28x9H	260	520	893	653	SAE 1 1/4"	BSP 3/4"
HM 15.0	650	990	N200x5x30x38x9H	305	520	950	681	SAE 1 1/4"	BSP 3/4"

Brake (Static / Parking)

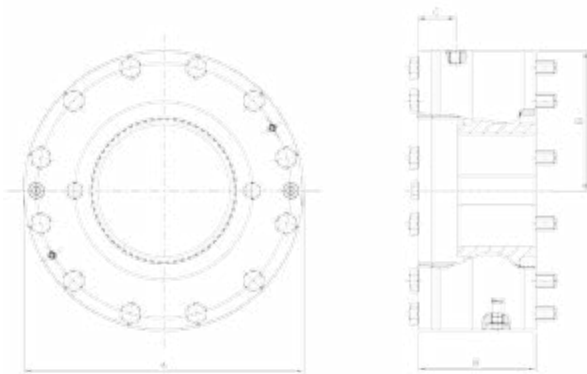

Motor Type	A(MM)	B(MM)	C(MM)	D(MM)	Break Release Pressure	Break Torque NM max
HM 12-15	480	195	62	260	20-30 Bar	60,000

* Technical Dimensions are subject to change without prior notice

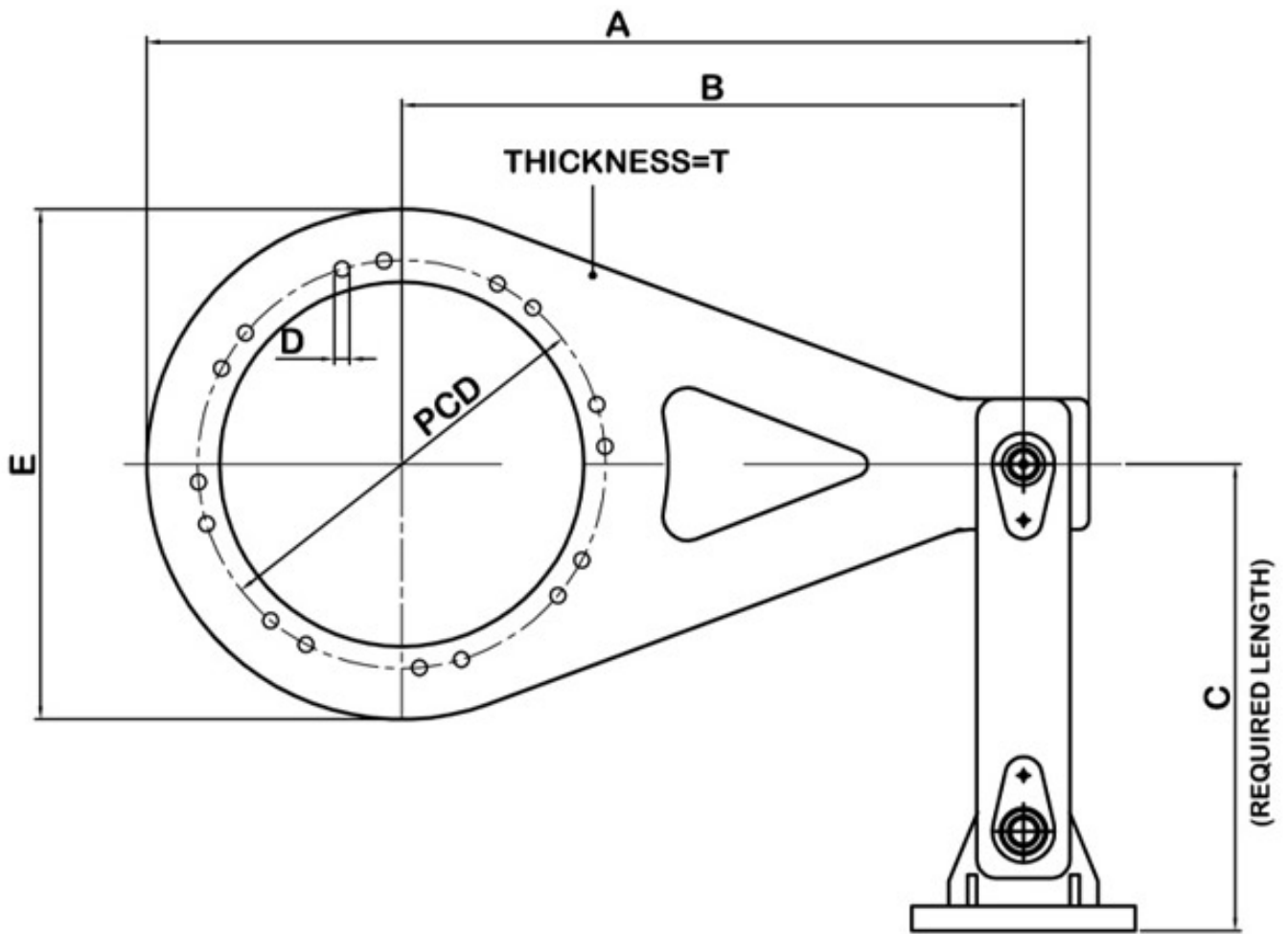

Motor	A	B	C	D	PCD	E	T	Weight
	(mm)	(mm)	(mm)	(mm)	(mm)	(mm)	(mm)	(kg)
TA 9 to 15	1430	1000	-	22	587	650	30	75

Technical data sheet-model destination code

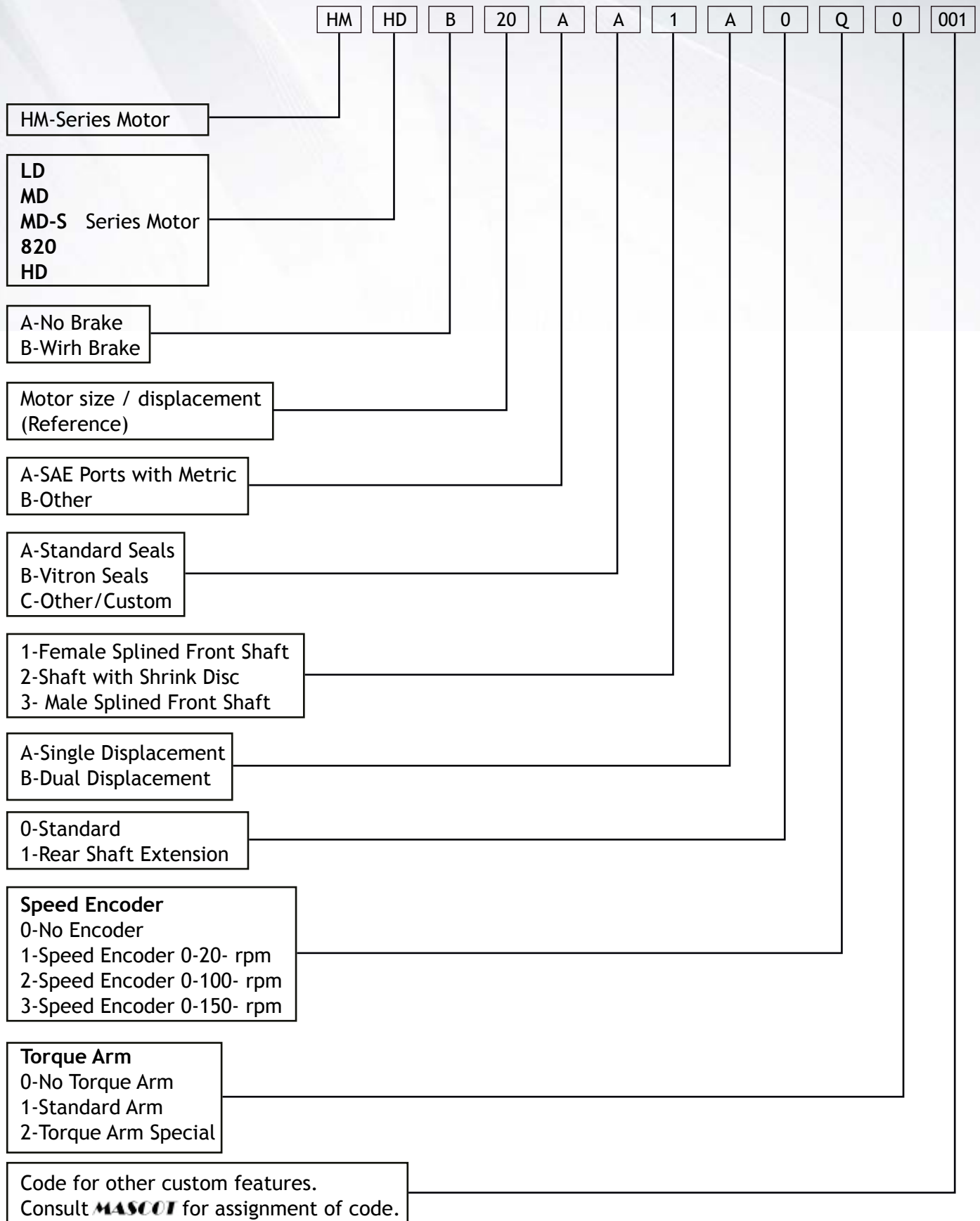

Application for High Torque Gearless Hydraulic System



Pulp & Paperindustry

- ▶ waste paperhandling
- ▶ cooking process
- ▶ washing and bleaching

Rubber& Plastics

- ▶ winch drives
- ▶ steering
- ▶ dredgers
- ▶ crawlers
- ▶ drive barges

Mining

- ▶ kiln drivers
- ▶ driers
- ▶ chemical
- ▶ evaporators
- ▶ mixers
- ▶ reactors
- ▶ dryers

Power

- ▶ conveyor
- ▶ reclaimer
- ▶ stacker
- ▶ bogie drives
- ▶ unloaders

Marine

- ▶ mouldingmachines
- ▶ process machines
- ▶ belt process
- ▶ screw drives

Material Handling

- ▶ conveyors
- ▶ wagon tippers
- ▶ side arm charges
- ▶ paddle feeders
- ▶ apron feeders
- ▶ stacker reclaimers
- ▶ crushers

Cement

- ▶ mill drives
- ▶ pressure feeders
- ▶ cane carriers
- ▶ cane unloaders

Sugar

- ▶ ball mills
- ▶ bowl mills
- ▶ feeder conveyors
- ▶ ash handling
- ▶ feeding gates
- ▶ conveyors



ISO 9001-2008 Certified



Dutch Hydraulic Consultants BV	Tel. : +31-(0)6-83695868
Achterweg ZZ 8	Mail : info@dhc-hydraulic.nl
3216 AB Abbenbroek	Web : www.dhc-hydraulic.nl
Nederland	