

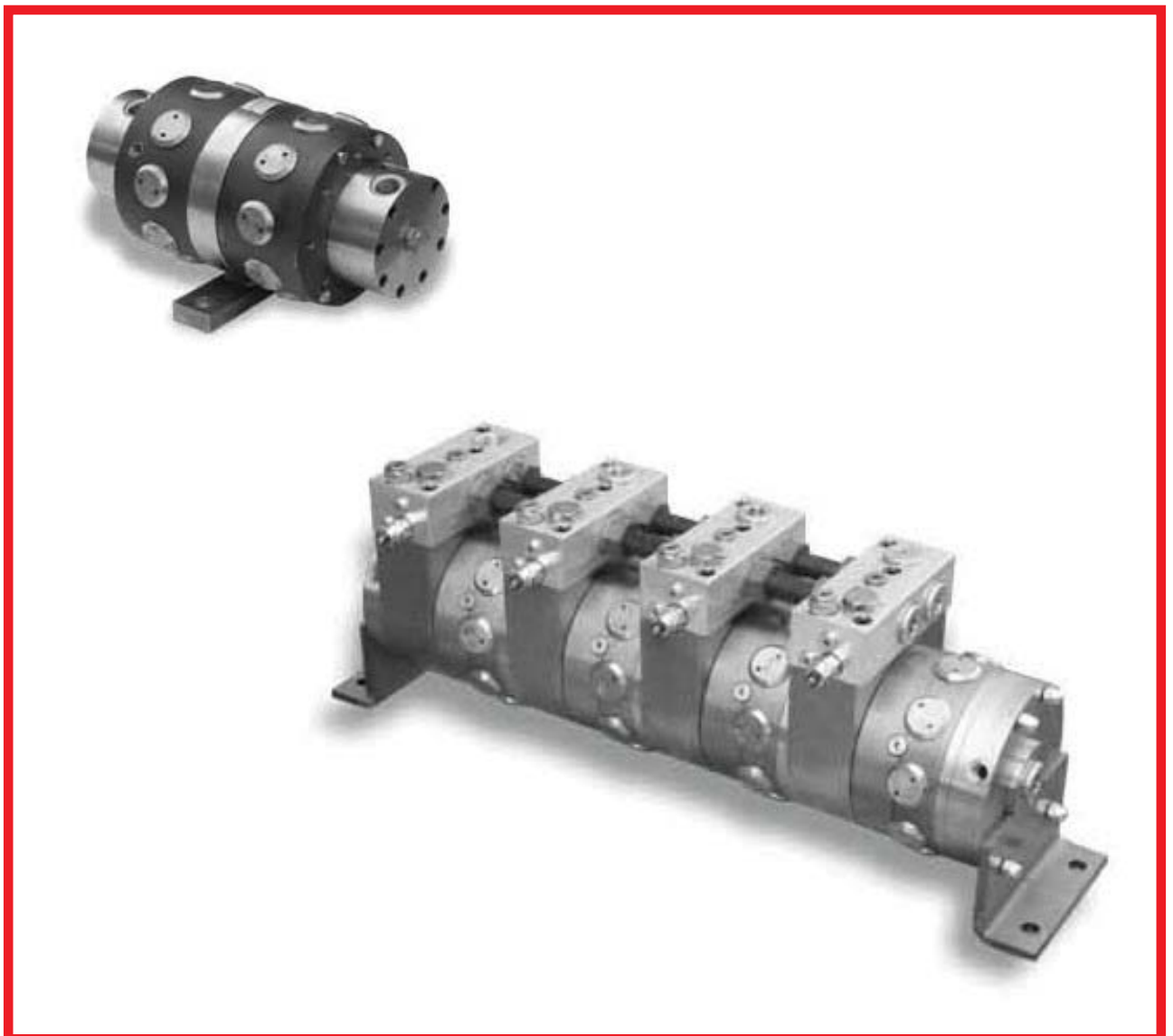

HYDRAULIC COMPONENTS
HYDROSTATIC TRANSMISSIONS
GEARBOXES - ACCESSORIES

HT 22 / D / 101 / 0310 / E

Radial Piston Flow Dividers FD / FDM Series



CONTENTS

Flow Dividers Technical Data.....	4
Hydraulic Fluid Recommendations.....	5
Instruction and Advices.....	6 - 7
Formulas and Conversions.....	8
FD 20-27-34 D20.....	9
FD 20-27-34 D21 VB.....	10
FD 50-75-90-100 D20.....	11
FD 50-75-90-100 D21 VB.....	12
FD 1 80-100-150 D47.....	13
FD 1 80-100-150 D47 VB.....	14
FD 2 250-350 D47.....	15
FD 2 250-350 D47 VB.....	16
FD 3 400-450-500-600 D47.....	17
FD 3 400-450-500-600 D47 VB.....	18
FD 4 800-900 D47.....	19
FD 4 800-900 D47 VB.....	20
FD 5 1400-1500-1600 D90.....	21
FD 5 1400-1500-1600 D90 VB.....	22
FD 6 2500-3000-3200-3500 D90.....	23
FD 6 2500-3000-3200-3500 D90 VB.....	24
FDM 34 D21.....	25
FDM 34 D21 VB.....	26
FDM 50-75-100 D21.....	27
FDM 50-75-100 D21 VB.....	28
Valve Dimensions and Technical Data.....	29
Hydraulic Circuit.....	30
Ordering Instructions (FD Series).....	31
Ordering Instructions (FDM Series).....	32
Flow Dividers Selection Chart.....	33

FLOW DIVIDERS TECHNICAL DATA

MODEL		N° of pistons per section	Displacement per section cc/rev	Pressure			Flow per section		Max power per section		Dry Weight kg
				Max Cont.	Max Int.	Max	Max Continuous	Max Int.			
				bar	bar	bar	l/min	l/min	HP	kW	
FD 20	FD	9	20	250	280	320	25	35	12	9	55
FD 27		9	27	250	280	320	35	50	16	12	55
FD 34		9	34	250	280	320	45	60	20	15	55
FD 50		9	51	250	280	320	60	80	27	20	65
FD 75		9	76	250	280	320	90	120	41	30	65
FD 90		9	89	250	280	320	110	140	48	35	65
FD 100		9	102	250	280	320	125	160	54	40	65
FD 1 80	FD 1	5	80	250	280	350	55	65	27	20	90
FD 1 100		5	100	250	280	350	70	85	34	25	90
FD 1 150		5	157	250	280	350	110	130	52	38	90
FD 2 250	FD 2	5	253	250	280	350	130	150	61	45	110
FD 2 350		5	362	250	280	350	165	190	79	58	110
FD 3 400	FD 3	5	397	250	280	350	170	190	82	60	180
FD 3 450		5	452	250	280	350	190	215	91	67	180
FD 3 500		5	491	250	280	350	210	230	101	74	180
FD 3 600		5	594	250	280	350	230	260	109	80	180
FD 4 800	FD 4	5	792	250	280	350	250	295	120	88	230
FD 4 900		5	904	250	280	350	285	335	139	100	230
FD 5 1400	FD 5	5	1376	250	280	300	290	340	119	87	460
FD 5 1500		5	1528	250	280	300	320	375	130	96	460
FD 5 1600		5	1648	250	280	300	350	400	143	105	460
FD 6 2500	FD 6	5	2525	250	280	300	390	460	160	118	900
FD 6 3000		5	2983	250	280	300	440	525	179	132	900
FD 6 3200		5	3289	250	280	300	460	550	188	138	900
FD 6 3500		5	3479	250	280	300	490	590	200	147	900
FDM 34	FDM	9	34	250	280	320	45	60	20	15	35 per section
FDM 50		9	51	250	280	320	60	80	27	20	45 per section
FDM 75		9	76	250	280	320	90	120	48	35	45 per section
FDM 100		9	102	250	280	320	125	160	54	40	45 per section

HYDRAULIC FLUIDS RECOMMENDATIONS

HYDRAULIC FLUIDS

We recommend the use of hydraulic oils with anti-wear additives (ISO HM or HV) and minimum viscosity index of 95. Once normal working temperature is reached, oil viscosity must be at least 44 cSt, preferably in the range from 50 to 80 cSt.

Hydraulic oils meeting Denison MF-O, Vickers M-2952-S I - 286-S performance requirements and DIN 51524 specifications, are preferred.

Pay particular attention if you use HE type oils (ecological fluid) because them can influence the motor seals compatibility, the motor performance and life. Please ask us for advice in case of HE type oils usage.

Mineral hydraulic oils are divided into four main types, designated by the International Standards Organisation (ISO) as HH, HL, HM and HV. We advise to use only products with HM or HV specifications.

HM type

These are the most widely employed hydraulic oils. They include small quantities of anti-wear additives to provide significant improvement in wear reduction. "Superior" quality HM type oils can be used for all equipment, with the added assurance that they will be suitable for the highest temperature.

HV type

HV hydraulic oils show minimal change in viscosity with temperature variations.

OIL VISCOSITY RECOMMENDATION

Room temperature HM type ISO-VG

- -20°C / 0°C BP ENERGOL HLP - HM 22
- -15°C / +5°C BP ENERGOL HLP - HM 32
- -8°C / +15°C BP BNERGOL HLP - HM 46
- 0°C / +22°C BP ENERGOL HLP - HM 68
- +8°C / +30°C BP ENERGOL HLP - HM100
- -20°C / +5°C BP BARTRAN HV 32
- -15°C / +22°C BP BARTRAN HV 46
- 0°C / +30°C BP BARTRAN HV 68

Our motors have been designed to work also with:

- oils type ATF (Automatic Transmission Fluid)
- oils with viscosity SAE 10W - 20 -30
- multigrade motor oils SAE 10 W/40 or 15 W/40
- universal oils

During cold start-up, avoid high-speed operation until the system is warmed up to provide adequate lubrication.

Continuous working temperature must not exceed 70°C. Every 5-8°C of increase from the optimum working temperature, the hydraulic fluid life decrease of about 40-50% (see OXIDATION). Therefore the motor life will be affected by consequence.

FIRE RESISTANT OIL LIMITATIONS

	Max cont. pressure	Max int. pressure	Max speed
HFA, 5-95% oil-water	103	138	50%
HFB, 60-40% oil-water	138	172	100%
HFC, water-glycol	103	138	50%
HFD, ester phosphate	250	293	100%

FILTRATION

Hydraulic systems oil must always be filtered.

The choice of filtration grade derives from needs of service life and money spent. In order to obtain stated service life it is important to follow our recommendations concerning filtration grade.

When choosing the filter it is important to consider the amount of dirt particles that filter can absorb and still operate satisfactorily. For that reason we recommend filters showing when you need to substitute filtering cartridge.

- 25 µm filtration required in most applications
- 10 µm filtration in closed circuit applications

OXIDATION

Hydraulic oil oxidizes with time of use and temperature. Oxidation causes changes in colour and smell, acidity increase or sludge formation in the tank. Oxidation rate increases rapidly at surface temperatures above 60°C, in these situations oil should be checked more often. Every 5-8°C of increase from the optimum working temperature, the hydraulic fluid life decrease of about 40-50%.

The oxidation process increases the acidity of the fluid; the acidity is stated in terms of the "neutralization number". Oxidation is usually slow at the beginning and then it increases rapidly.

A sharp increase (by a factor of 2 to 3) in neutralization number between inspections shows that oil has oxidized too much and should be replaced immediately.

WATER CONTENT

Oil contamination by water can be detected by sampling from the bottom of the tank. Most hydraulic oils repel the water, which then collects at the bottom of the tank. This water must be drained off at regular intervals. Certain types of transmission oils and engine oils emulsify the water; this can be detected by coatings on filter cartridges or a change in the colour of the oil. In such cases, obtain your oil supplier advice.

DEGREE OF CONTAMINATION

Heavy contamination of the oil causes wear rising in hydraulic system components. Contamination causes must be immediately investigated and remedied.

ANALYSIS

In optimum operating conditions, we recommend to perform an oil analysis 6 months. The analysis should cover viscosity, oxidation, water content, additives and contamination. Most oil suppliers are equipped to analyze oil state and to recommend appropriate action. Oil must be immediately replaced if the analysis shows that it is exhausted.

INSTRUCTIONS AND ADVICES

GENERAL INFORMATION ON FLOW DIVIDERS

If several motors or cylinders are operate from a single pump without any means of controlling their individual flows only the motor or cylinder with the lowest pressure requirement would start its work cycle. The motor or cylinder with the next lower pressure requirement would only start when the first unit has completed its work cycle. This mode of operation is normally undesirable, the total pump flow must therefore be divided into a series of partial flows. This can be obtained in the following ways:

- Throttles or flow regulation valves in each motor or cylinder connection;
- Operating the units in a series circuit;
- By the flow dividers utilisation.

INSTALLATION

Hoses and piping must be clean and free from contamination. No other special requirements are necessary.

- Always advises the application datasheet compilation to help the customer to perform the best flow divider type selection
- Flow divider can be mounted in any position
- In all the working conditions suggests the valve block version selection
- Consult factory for intermittent applications

START UP

The flow divider case and pistons must be completely filled with oil before starting. Infact, the drain line piping must be installed in a way that doesn't allow that the flow divider can be empty. Due to the low drain quantity it is absolutely necessary fill completely the flow divider before the start-up (this is fundamental for the first start-up especially). Do not load the flow divider immediately at the maximum pressure and speed but increase the load gradually at start-up. Especially when the flow divider has a small displacement, do not start the flow divider when the outlet pressure is already at the maximum value.

CASE DRAIN – CASE PRESSURE

The flow dividers have many drain ports that are internally connected together. At least one of these drain ports must be connected to the tank. For continuous use flushing is required to maintain the operating fluid viscosity between the recommended values (see Hydraulics fluid recommendations). The case pressure must not exceed 20 bar, in order to avoid the mechanical parts failure and flow divider leakage.

TEMPERATURE

Refer to hydraulic fluid recommendations.

VISCOSITY

Refer to hydraulic fluid recommendations.

HIGH PRESSURE APPLICATIONS

In case of high pressure applications, a Nitemper treatment on motor body or in cylinders it is suggested to increase wear and tear resistance.

MINIMUM FLOWS

The minimum recommended flow per section can be calculated as the 20% of the maximum continuous flow (refer to the flow dividers technical data).

SYNCHRONISATION

Flow dividers are of the radial piston design. Thanks to this characteristic, they can reach a very high accuracy. The synchronisation error depends by different factors:

- Oil viscosity and temperature;
- System pressure mean value and variability;
- Total flow rate that must be divided.

The approximate synchronisation error is about $\pm 0.5\%$. This synchronisation degree is maintained over a wide flow range. In addition, due to the low leakage rate located in every individual section, the high synchronisation degree is maintained with different load conditions.

The flow dividers are not able to compensate the errors caused by different oil compression deriving from different cylinder loads: therefore it is recommended minimize the oil volumes between the flow divider and the hydraulic actuators by the usage of short pipes (of the same diameter) of equal length foe each actuator. If this is not enough the synchronization error can be reduced or eliminated by an adequate use of relief pressure valves.

SYNCHRONIZATION RATIO

In general, the synchronization ratio is 1:1. Other synchronization ratios are possible, to obtain more details please contact technical departement.

INTERNAL PRESSURE DROP

The minimum recommended flow per section can be calculated as the 20% of the maximum continuous flow (refer to the flow dividers technical data). To minimize the internal pressure drop, that is higher when the flow divider is working at high working pressures, basing on the fact that often the flow divider works in only one direction, the flow divider can be realized, for example, in the return line. Another possibility to reduce the pressure drop, when the synchronization is required in the low pressures working phase only, the flow divider can be by-passed during the high pressure working phase by using check valves.

APPROXIMATED INTERNAL PRESSURE DROP ESTIMATION

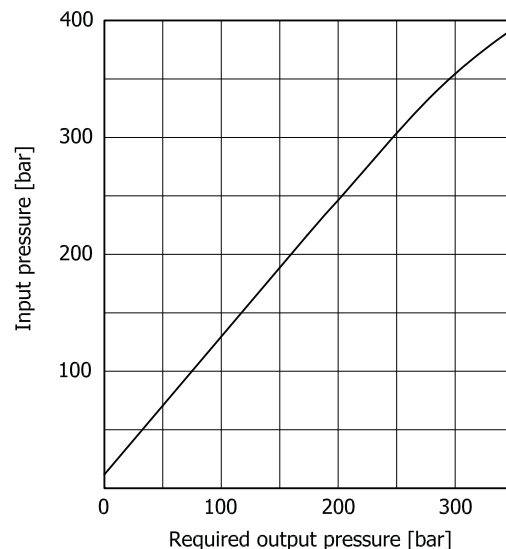

INSTRUCTIONS AND ADVICES

VALVES

Can provide balancing valves directly assembled on flow dividers. These valves are assembled together by the utilization of steel pipes supplied by to minimize the piping and fitting problems (see the next pages for more details).

INSTALLATION CIRCUIT

The use of flow dividers is not complicate if the hydraulic circuit has an appropriate design. Additional installation operations are not necessary. See even the internal pressure drop paragraph for more details.

In some special conditions, for example when the load is not sufficiently high to create the minimum pressure difference that is needed to win the flow divider internal pressure, the user can add a further section (with equal or bigger displacement than the other sections) with the return line of this section directly connected to the tank.

With reference at the application example circuits, the check valves assure a minimum pressure in each flow divider section (in other words they act as anticavitation valves). The M1, M2 and M3 ports can be used as manometer ports. Refer to page 29 to obtain more details about the valve data and circuit.

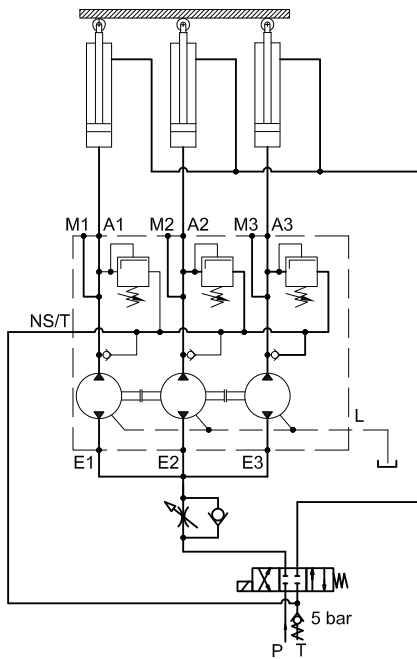

Flow divider application to control three cylinders

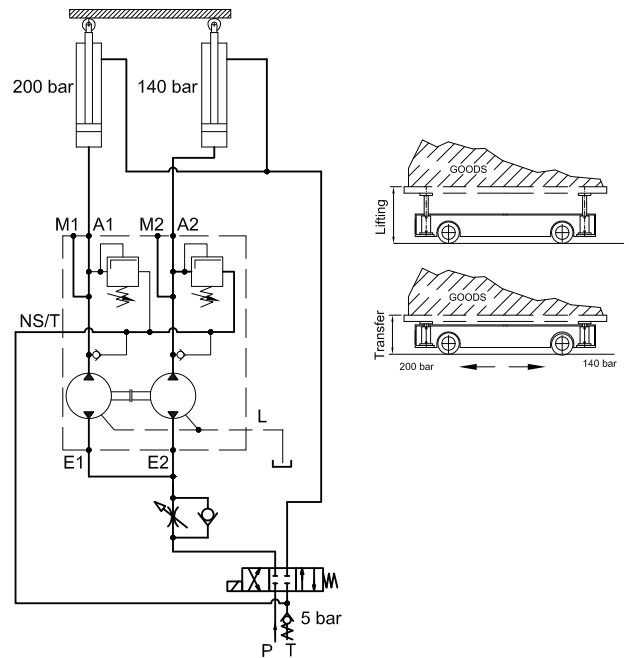

Example: flow divider application circuit on a lifting truck

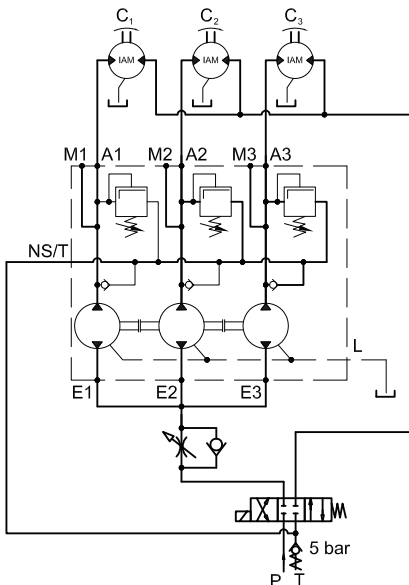

Flow divider application to control three motors

FORMULAS

- TORQUE (1) $\text{Torque} = (\text{specific torque}) \cdot (\text{pressure})$
- TORQUE (2) $\text{Torque [Nm]} = \frac{\text{displacement [cc/rev]} \cdot \text{pressure [bar]}}{62.8}$
- POWER (1) $\text{Power [kW]} = \frac{\text{Torque [Nm]} \cdot \text{speed [rpm]}}{9549}$
- POWER (2) $\text{Power [CV]} = \frac{\text{Torque [Nm]} \cdot \text{speed [rpm]}}{7023}$
- SPEED $\text{speed [rpm]} = \frac{\text{flow rate [l/min]} \cdot 1000}{\text{displacement [cc/rev]}}$
- REQUIRED MOTOR DISPLACEMENT $\text{displacement [cc/rev]} = \frac{\text{max required torque [Nm]} \cdot 62.8}{\text{max pressure [bar]}}$
- REQUIRED PUMP FLOW RATE $\text{flow [l/min]} = \frac{\text{displacement [cc/rev]} \cdot \text{max speed [rpm]}}{1000}$

CONVERSIONS

LENGTH	1 m	=	39.3701 in		1 lbf	=	0.4536 kgf
		=	3.2808 ft			=	4.448 N
		=	1.0936 yd				
		=	1000 mm	PRESSURE	1 bar	=	14.223 psi
1 in	=	0.0833 ft				=	0.99 atm
	=	25.4 mm				=	1.02 ata
1 ft	=	0.3048 m				=	100000 Pa
	=	0.3333 yd				=	100 kPa
	=	12 in				=	0.1 MPa
1 yd	=	0.9144 m			1 psi	=	0.0703 bar
	=	3 ft					
	=	36 in	FLOW	1 l/min	=	0.264 gpm	
1 km	=	1000 m			=	1000 cc/min	
	=	1093.6 yd		1 gpm	=	3.785 l/min	
	=	0.6214 mile			=	3785 cc/min	
1 mile	=	1.609 km		1 m ³ /s	=	60000 l/min	
	=	1760 yd			=	15852 gpm	
MASS	1 kg	=	2.2046 lb	VOLUME	1 m ³	=	1000 l
	1 lb	=	0.4536 kg		1 l	=	61,023 in ³
						=	0,264 galUS
SPEED	1 m/s	=	3.6 km/h		1 in ³	=	0,01639 l
		=	2.237 mph			=	16,39 cm ³
		=	3.2808 ft/s			=	0,004326 galUS
1 km/h	=	0.2778 m/s		1 galUS	=	3,7879 l	
	=	0.6214 mph			=	231,15 in ³	
	=	0.9113 ft/s	POWER	1 kW	=	1.341 HP	
1 mph	=	1.609 km/h			=	1.3596 CV	
	=	0.447 m/s		1 HP	=	0.7457 Kw	
	=	1.467 ft/s			=	1.0139 CV	
1 ft/s	=	0.3048 m/s	TORQUE	1 Nm	=	0.102 kgm	
	=	1.0973 km/h			=	0.7376 lbf ft	
	=	0.6818 mph		1 kgm	=	9.806 Nm	
FORCE	1 N	=	0.102 kgf		=	7.2325 lbf ft	
		=	0.2248 lbf		1 lbf ft	=	0.1383 kgm
1 kgf	=	2.205 lbf			=	1.3558 Nm	
	=	9.806 N					

SIZE

FD 20-27-34 D20

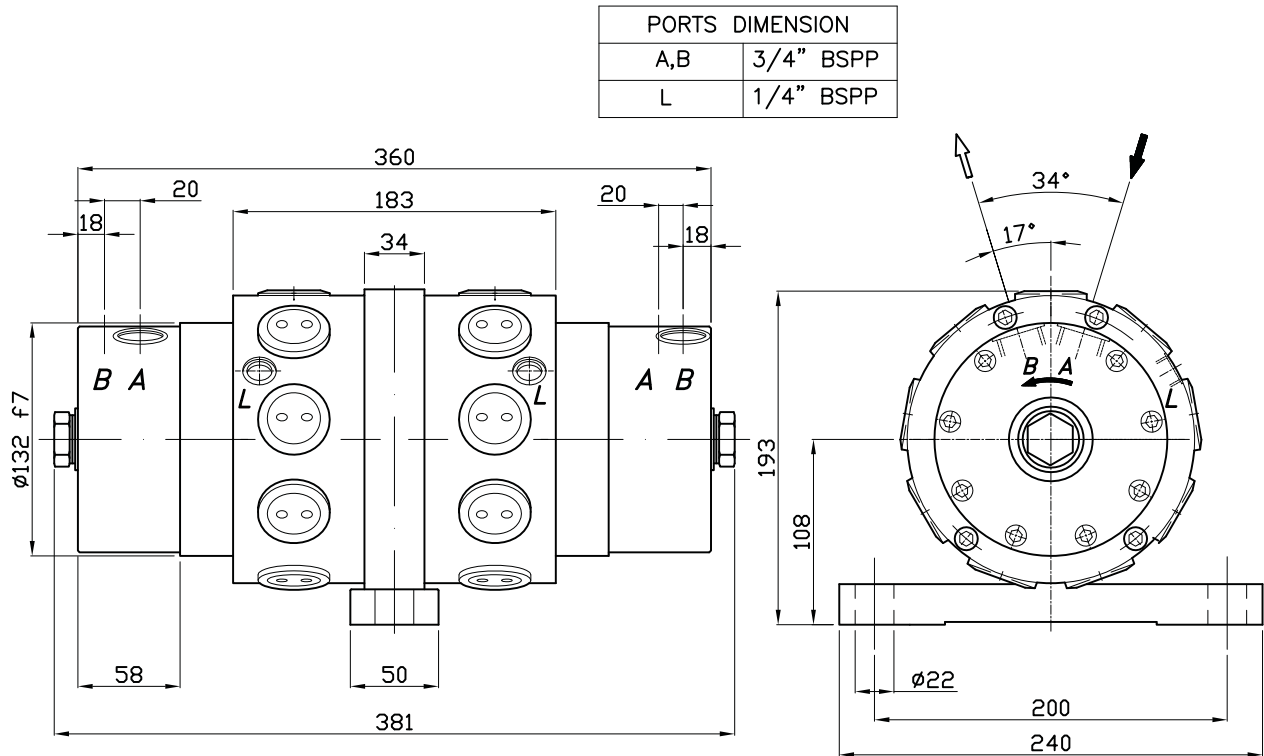

TECHNICAL DATA

FD 20-27-34 D20

MODEL	Flow per section		Displacement per section cc/Rev	Working pressure			Power per section kW
	l/min (cont)	l/min (max)		continuous bar	intermittent bar	maximum bar	
FD20	25	35	20	250	280	320	9
FD27	35	50	27	250	280	320	12
FD34	45	60	34	250	280	320	15

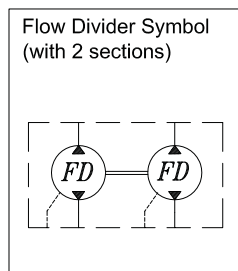

Dry weight 55 kg

Max case pressure 20 bar

SIZE

FD 20-27-34 D21 VB

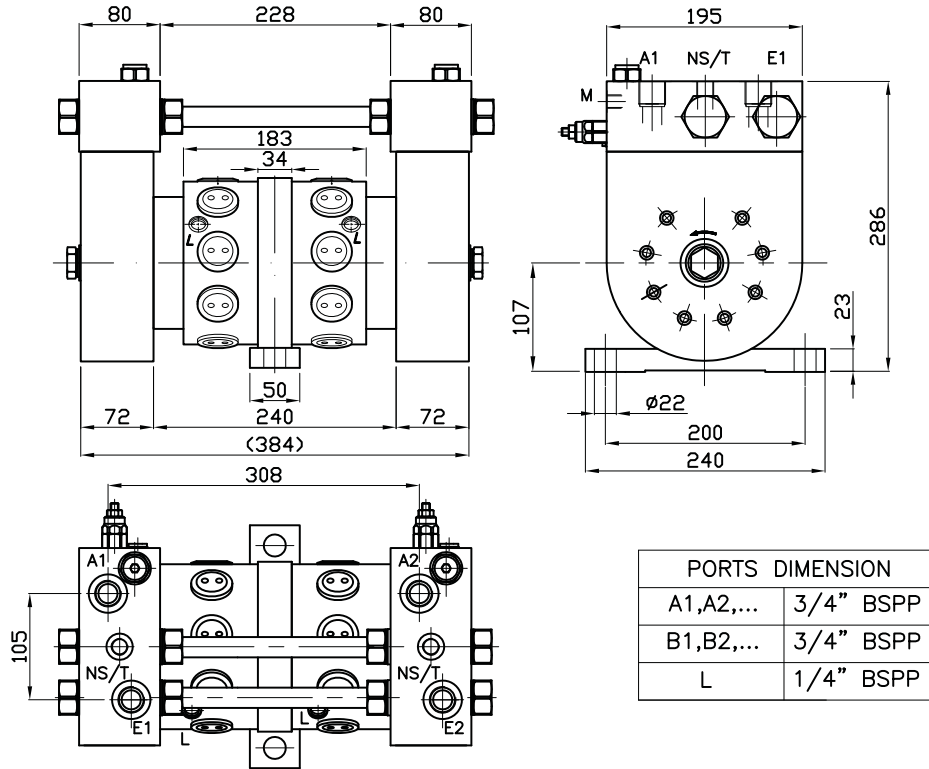

TECHNICAL DATA

FD 20-27-34 D21 VB

MODEL	Flow per section		Displacement per section cc/Rev	Working pressure			Power per section kW
	l/min (cont)	l/min (max)		continuous bar	intermittent bar	maximum bar	
FD20	25	35	20	250	280	320	9
FD27	35	50	27	250	280	320	12
FD34	45	60	34	250	280	320	15

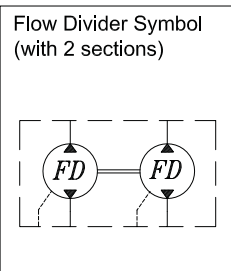

Refer to page 29 for valve technical data, valve dimensions and hydraulic circuit.

Dry weight 55 kg

Max case pressure 20 bar

SIZE

FD 50-75-90-100 D20

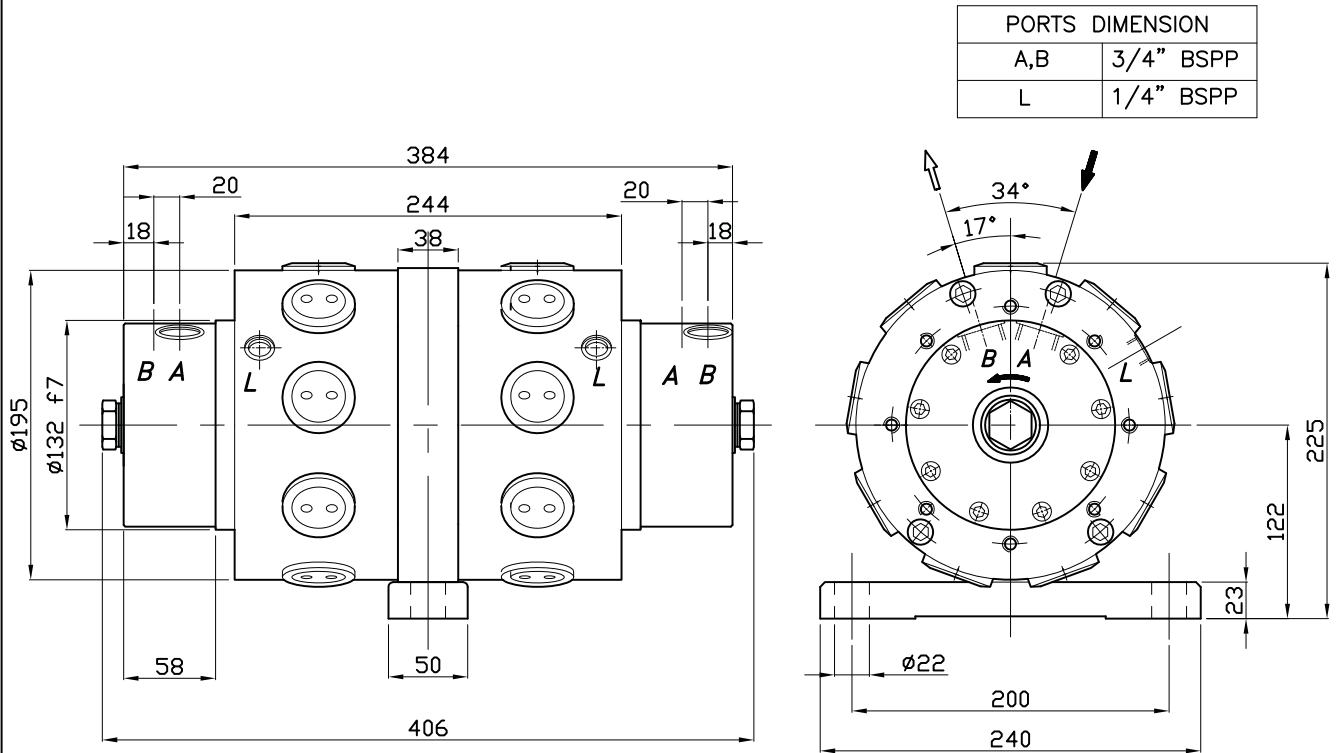

TECHNICAL DATA

FD 50-75-90-100 D20

MODEL	Flow per section		Displacement per section cc/Rev	Working pressure			Power per section kW
	l/min (cont)	l/min (max)		continuous bar	intermittent bar	maximum bar	
FD50	60	80	50	250	280	320	20
FD75	90	120	76	250	280	320	30
FD90	110	140	89	250	280	320	35
FD100	125	160	101	250	280	320	40

Flow Divider Symbol
(with 2 sections)

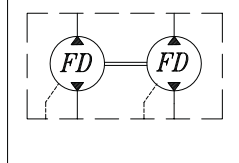

Dry weight 65 kg

Max case pressure 20 bar

SIZE

FD 50-75-90-100 D21 VB

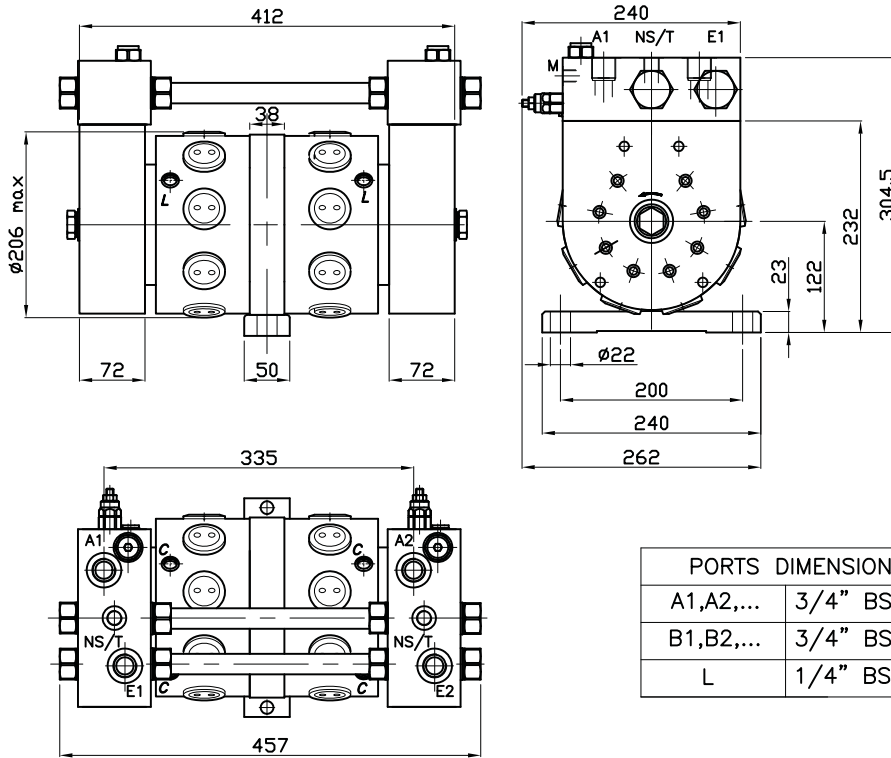

TECHNICAL DATA

FD 50-75-90-100 D21 VB

MODEL	Flow per section		Displacement per section cc/Rev	Working pressure			Power per section kW
	l/min (cont)	l/min (max)		continuous bar	intermittent bar	maximum bar	
FD50	60	80	50	250	280	320	20
FD75	90	120	76	250	280	320	30
FD90	110	140	89	250	280	320	35
FD100	125	160	101	250	280	320	40

Refer to page 29 for valve technical data, valve dimensions and hydraulic circuit.

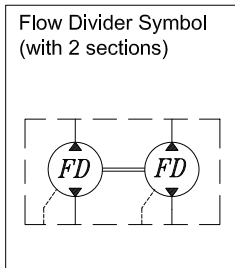

Dry weight 65 kg

Max case pressure 20 bar

SIZE

FD 1 80-100-150 D47

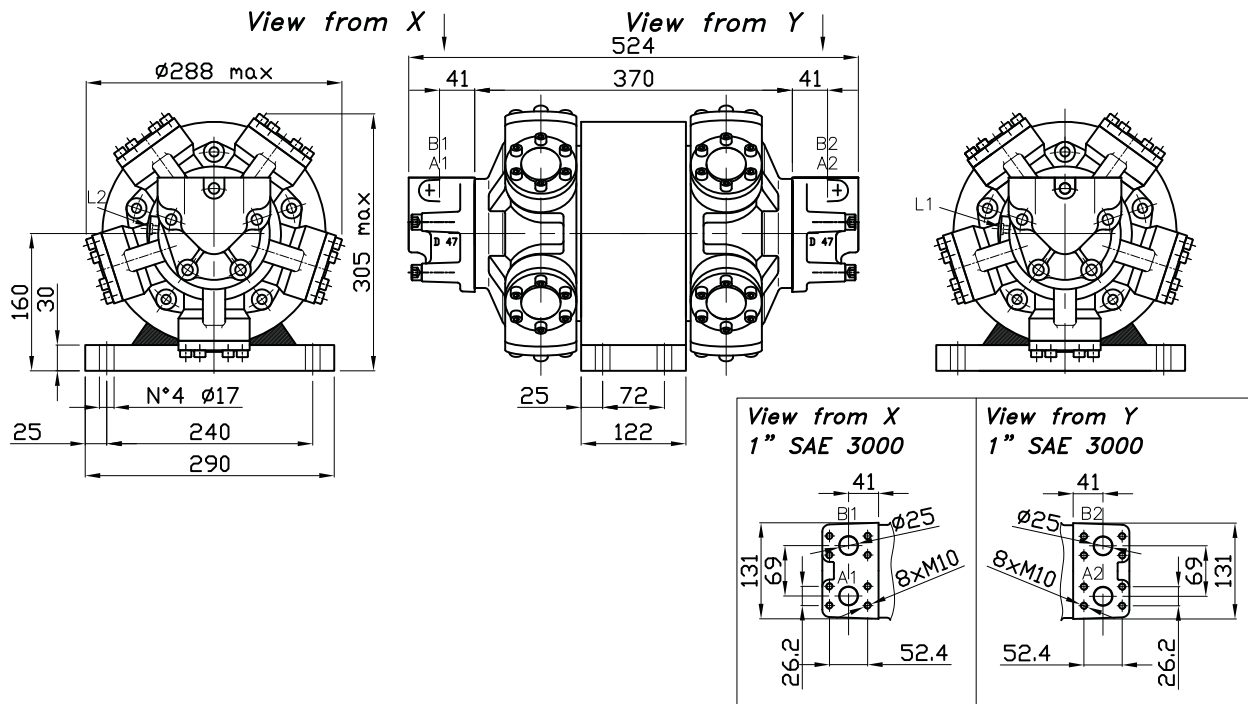

TECHNICAL DATA

FD 1 80-100-150 D47

MODEL	Flow per section		Displacement per section cc/Rev	Working pressure			Power per section kW
	l/min (cont)	l/min (max)		continuous bar	intermittent bar	maximum bar	
FD 1 80	55	65	80	250	280	350	20
FD 1 100	70	85	100	250	280	350	25
FD 1 150	110	130	157	250	280	350	38

Flow Divider Symbol
(with 2 sections)

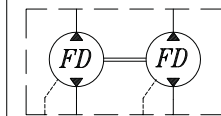

PORTS DIMENSION
L1/L2 3/8" BSP

Dry weight 90 kg

Max case pressure 20 bar

SIZE

FD 1 80-100-150 D47 VB

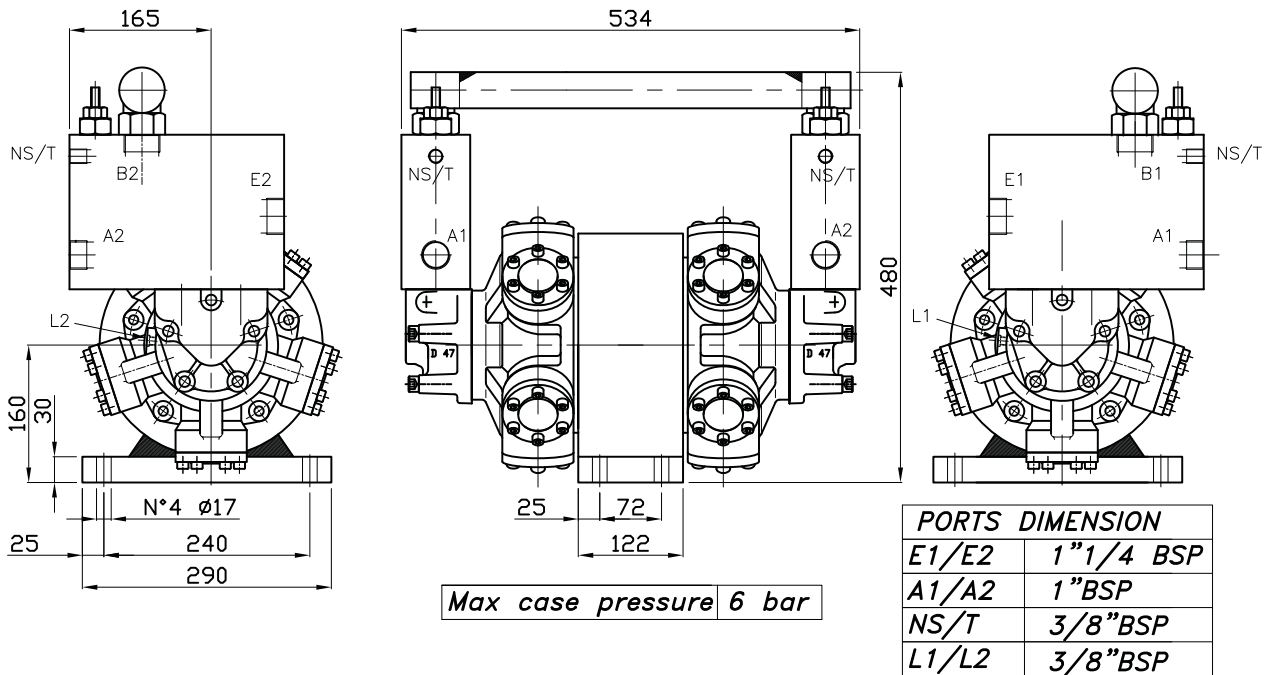

TECHNICAL DATA

FD 1 80-100-150 D47 VB

MODEL	Flow per section		Displacement per section cc/Rev	Working pressure			Power per section kW
	l/min (cont)	l/min (max)		continuous bar	intermittent bar	maximum bar	
FD 1 80	55	65	80	250	280	350	20
FD 1 100	70	85	100	250	280	350	25
FD 1 150	110	130	157	250	280	350	38

Flow Divider Symbol
(with 2 sections)

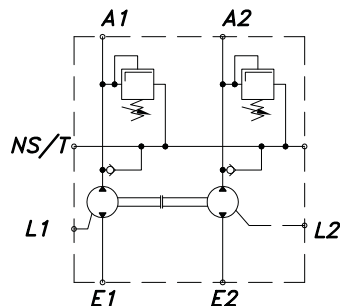
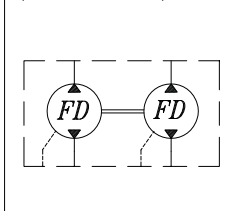

RELIEF VALVE DATA

Rated flow	40 l/min
Adjustable pressure range	5-50 bar
	30-100 bar
	50-220 bar
	80-350 bar

Dry weight 90 kg

Max case pressure 20 bar

SIZE

FD 2 250-350 D47

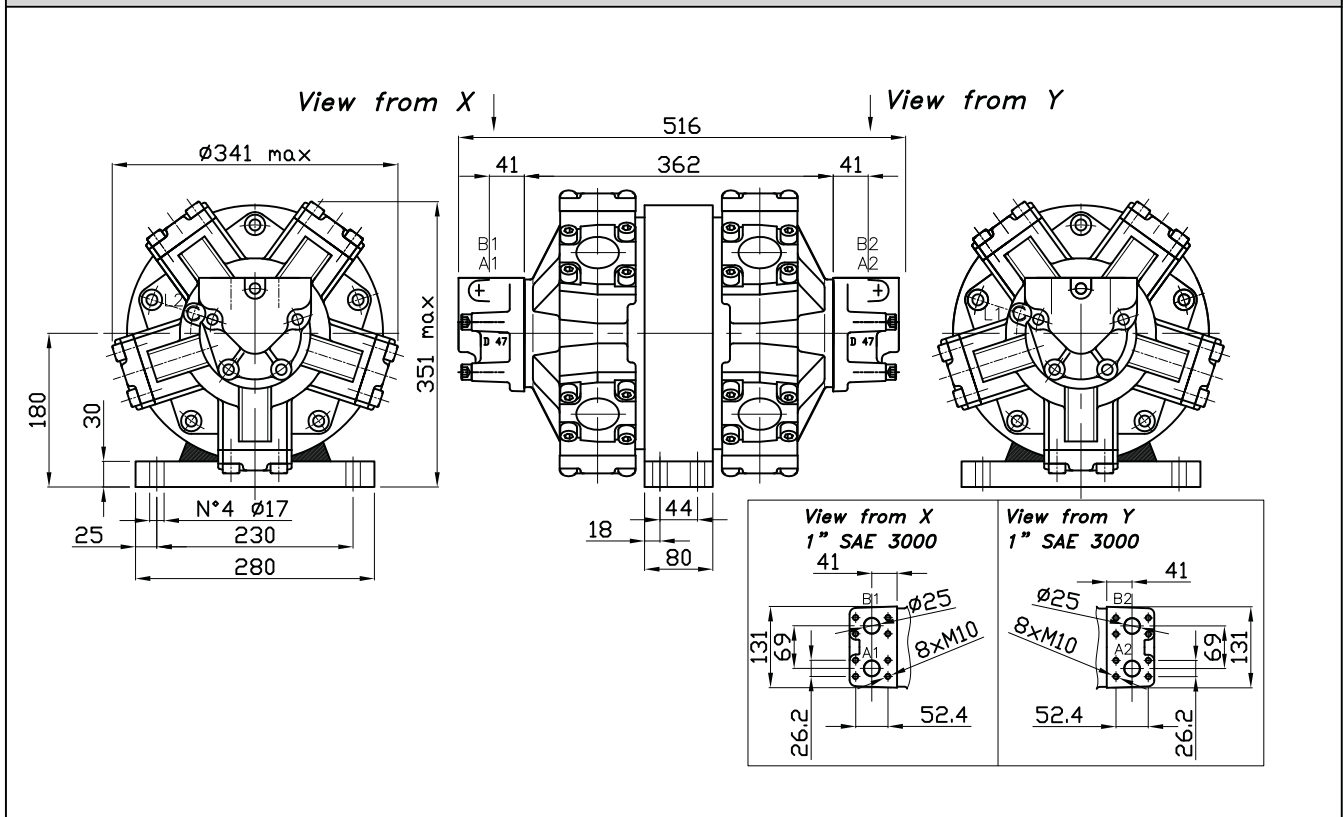

TECHNICAL DATA

FD 2 250-350 D47

MODEL	Flow per section		Displacement per section cc/Rev	Working pressure			Power per section kW
	l/min (cont)	l/min (max)		continuous bar	intermittent bar	maximum bar	
FD 2 250	130	150	253	250	280	350	45
FD 2 350	165	190	362	250	280	350	58

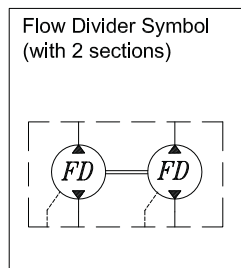

PORTS DIMENSION	
L1/L2	3/8" BSP

Dry weight 110 kg

Max case pressure 20 bar

SIZE

FD 2 250-350 D47 VB

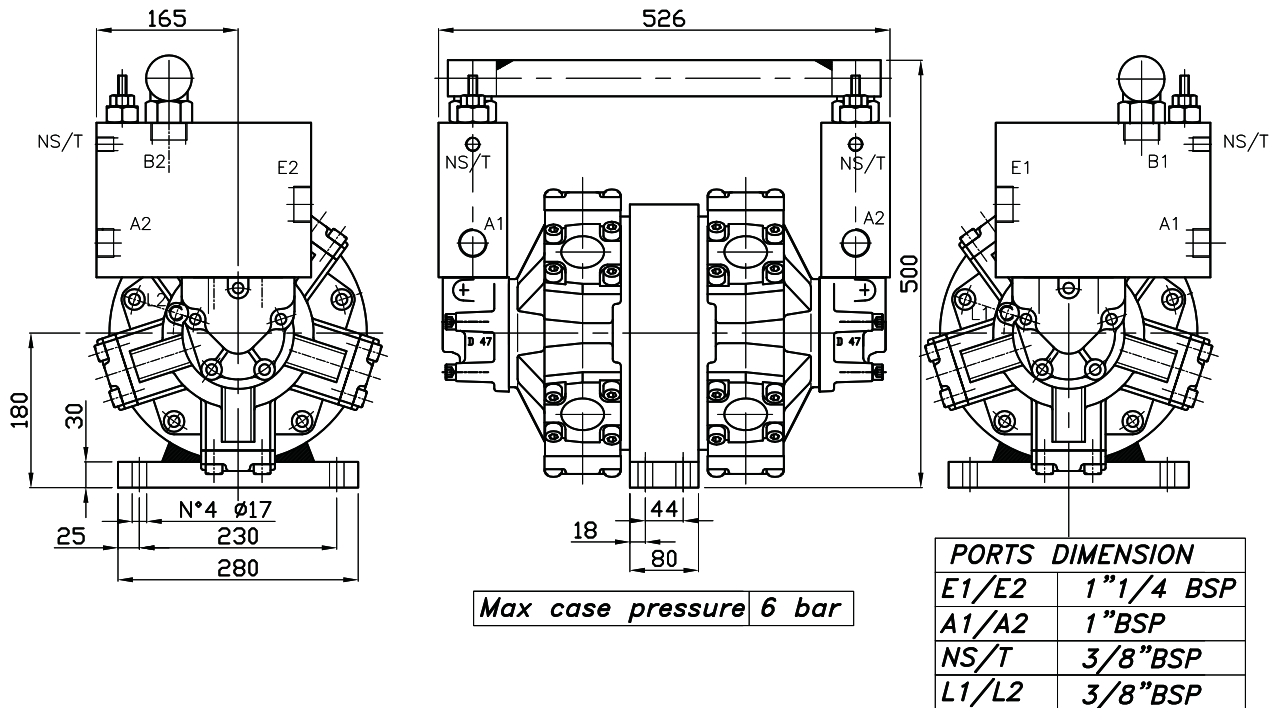

TECHNICAL DATA

FD 2 250-350 D47 VB

MODEL	Flow per section		Displacement per section cc/Rev	Working pressure			Power per section kW
	l/min (cont)	l/min (max)		continuous bar	intermittent bar	maximum bar	
FD 2 250	130	150	253	250	280	350	45
FD 2 350	165	190	362	250	280	350	58

Flow Divider Symbol
(with 2 sections)

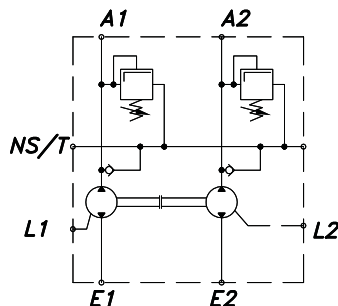
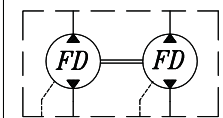

RELIEF VALVE DATA

Rated flow	40 l/min
Adjustable pressure range	5-50 bar
	30-100 bar
	50-220 bar
	80-350 bar

Dry weight 110 kg

Max case pressure 20 bar

SIZE

FD 3 400-450-500 D47

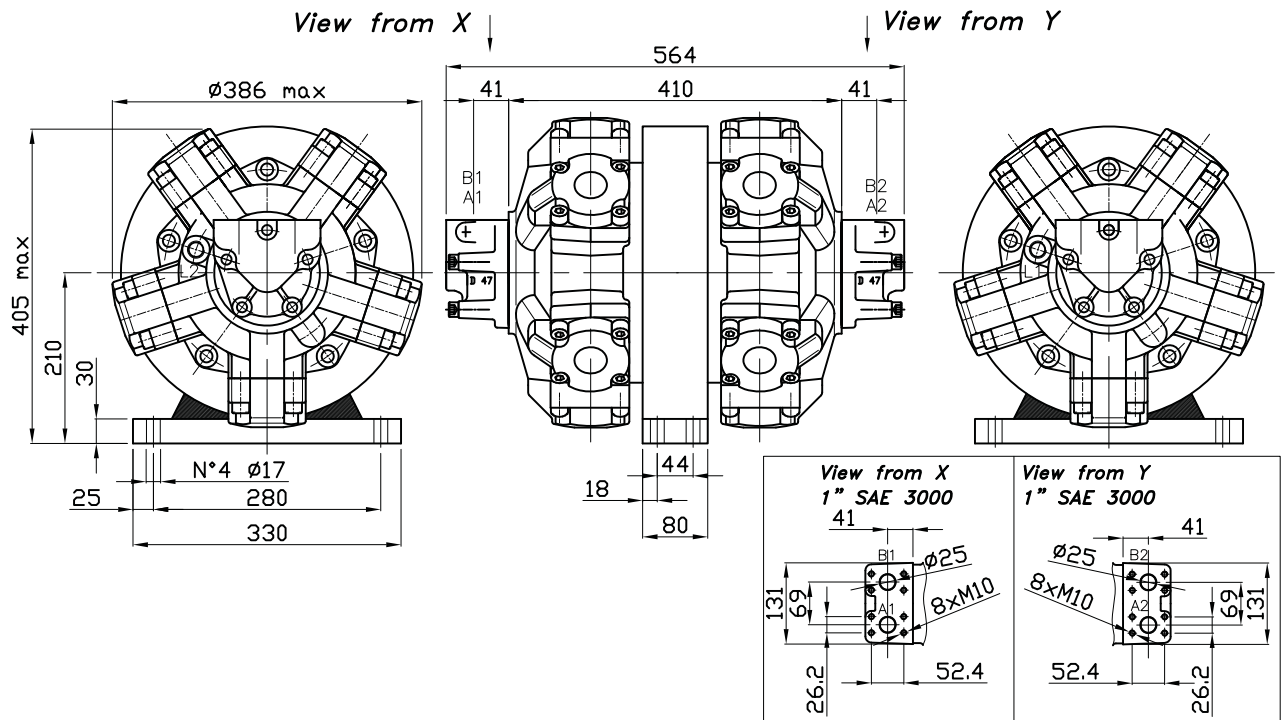

TECHNICAL DATA

FD 3 400-450-500 D47

MODEL	Flow per section		Displacement per section cc/Rev	Working pressure			Power per section kW
	l/min (cont)	l/min (max)		continuous bar	intermittent bar	maximum bar	
FD 3 400	170	190	397	250	280	350	60
FD 3 450	190	215	452	250	280	350	67
FD 3 500	210	230	491	250	280	350	74
FD 3 600	230	260	594	250	280	350	80

Flow Divider Symbol
(with 2 sections)

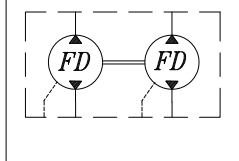

PORTS DIMENSION

L1/L2 | 1/2" BSP

Dry weight | 180 kg

Max case pressure | 20 bar

SIZE

FD 3 400-450-500 D47 VB

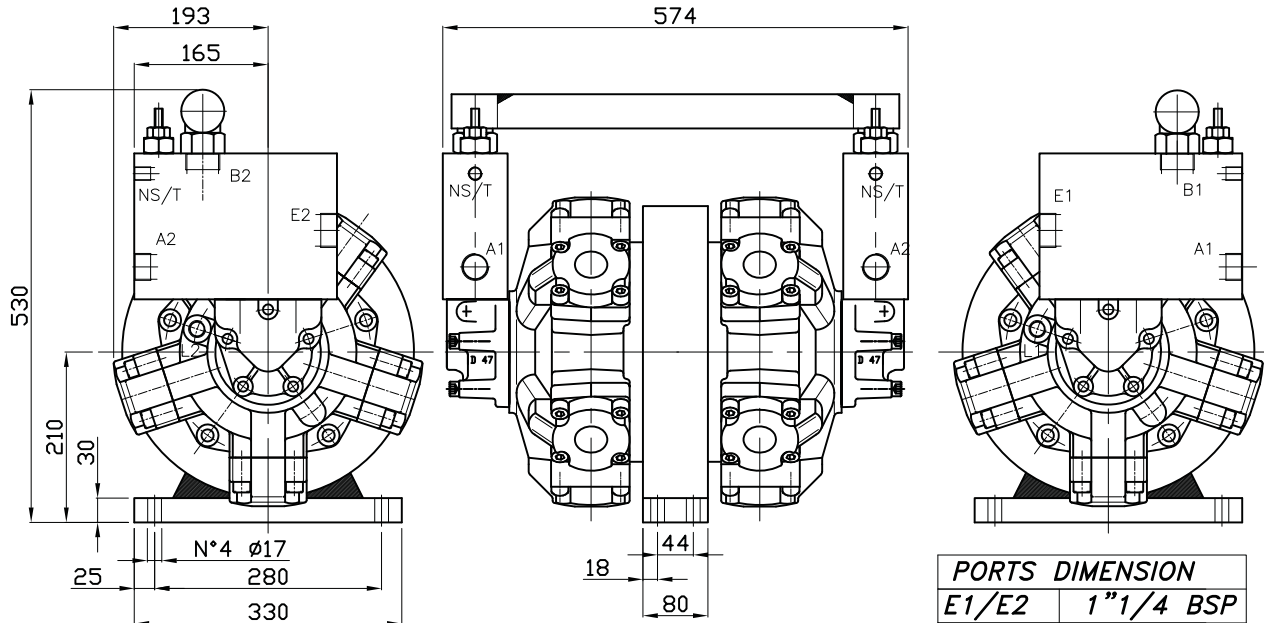

Max case pressure 6 bar

PORTS DIMENSION	
E1/E2	1 1/4" BSP
A1/A2	1" BSP
NS/T	3/8" BSP
L1/L2	1/2" BSP

TECHNICAL DATA

FD 3 400-450-500 D47 VB

MODEL	Flow per section		Displacement per section cc/Rev	Working pressure			Power per section kW
	l/min (cont)	l/min (max)		continuous bar	intermittent bar	maximum bar	
FD 3 400	170	190	397	250	280	350	60
FD 3 450	190	215	452	250	280	350	67
FD 3 500	210	230	491	250	280	350	74
FD 3 600	230	260	594	250	280	350	80

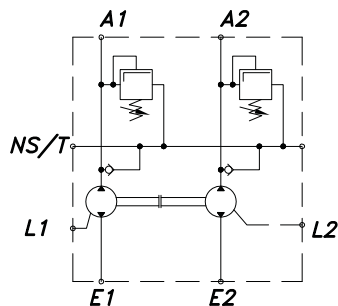
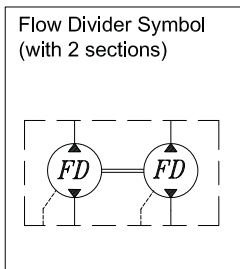

RELIEF VALVE DATA	
Rated flow	40 l/min
Adjustable pressure range	5-50 bar
	30-100 bar
	50-220 bar
	80-350 bar

Dry weight 180 kg

Max case pressure 20 bar

SIZE

FD 4 800-900 D47

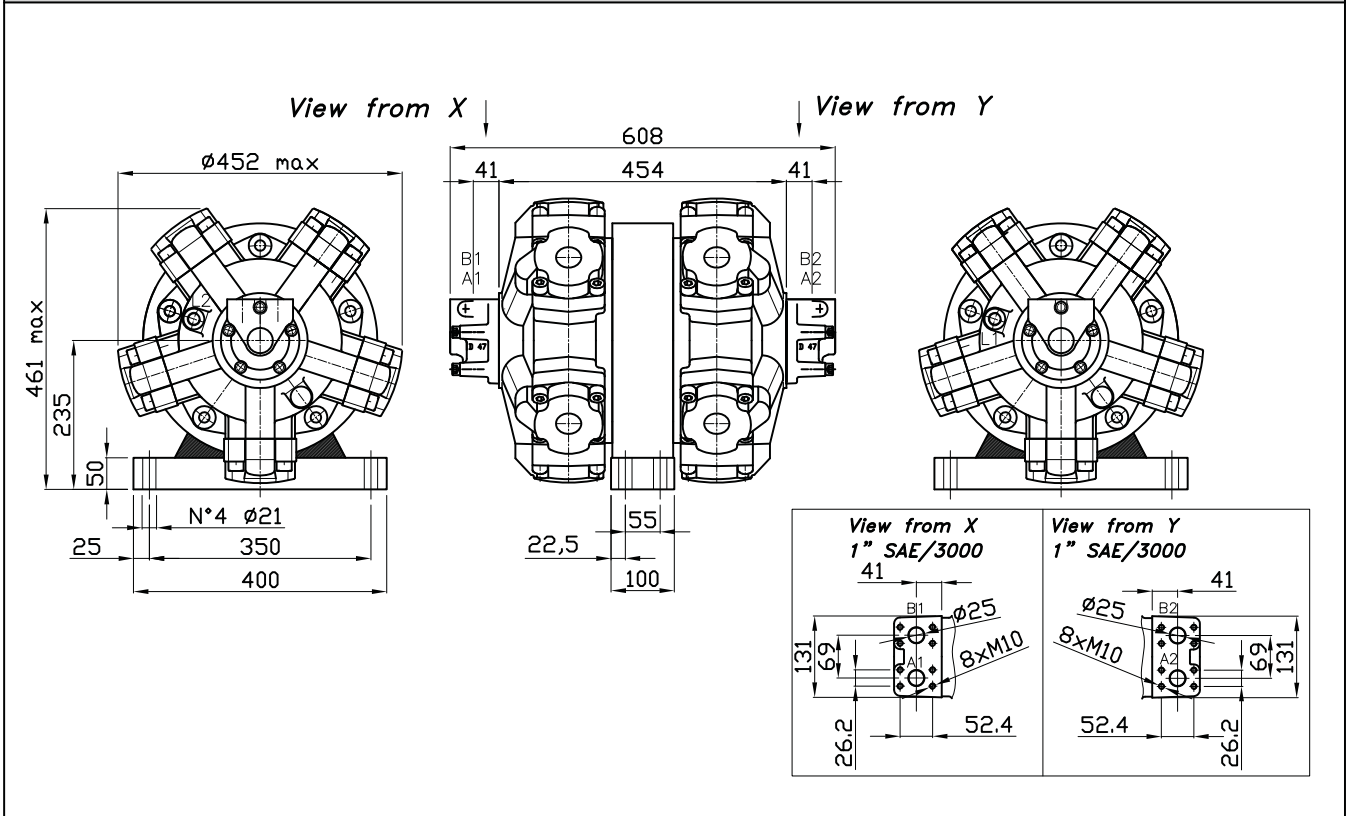

TECHNICAL DATA

FD 4 800-900 D47

MODEL	Flow per section		Displacement per section cc/Rev	Working pressure			Power per section kW
	l/min (cont)	l/min (max)		continuous bar	intermittent bar	maximum bar	
FD 4 800	250	295	792	250	280	350	88
FD 4 900	285	335	904	250	280	350	100

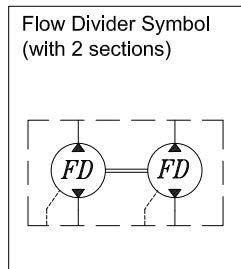

PORTS DIMENSION	
L1/L2	1/2" BSP

Dry weight 230 kg

Max case pressure 20 bar

SIZE

FD 4 800-900 D47 VB

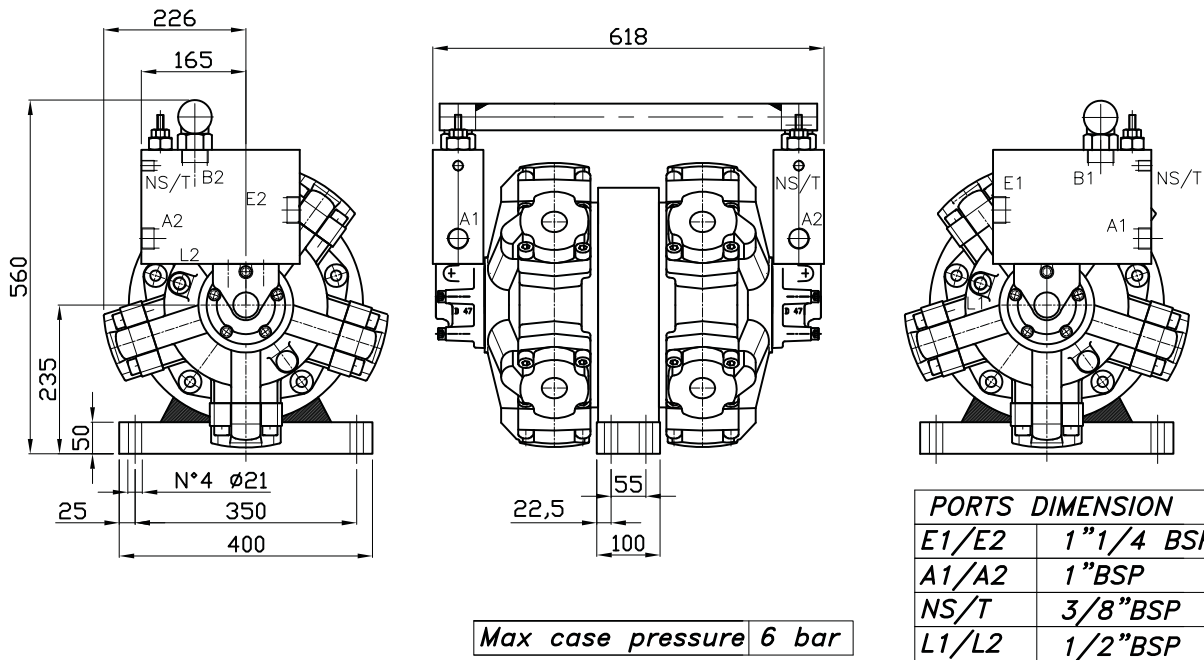

TECHNICAL DATA

FD 4 800-900 D47 VB

MODEL	Flow per section		Displacement per section cc/Rev	Working pressure			Power per section kW
	l/min (cont)	l/min (max)		continuous bar	intermittent bar	maximum bar	
FD 4 800	250	295	792	250	280	350	88
FD 4 900	285	335	904	250	280	350	100

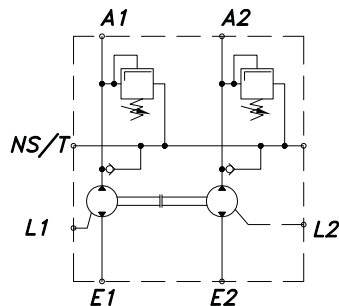
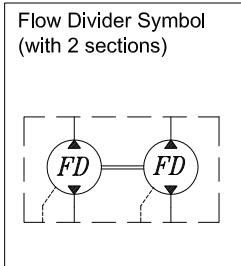

RELIEF VALVE DATA	
Rated flow	40 l/min
Adjustable pressure range	5-50 bar
	30-100 bar
	50-220 bar
	80-350 bar

Dry weight 230 kg

Max case pressure 20 bar

SIZE

FD 5 1400-1500-1600 D90

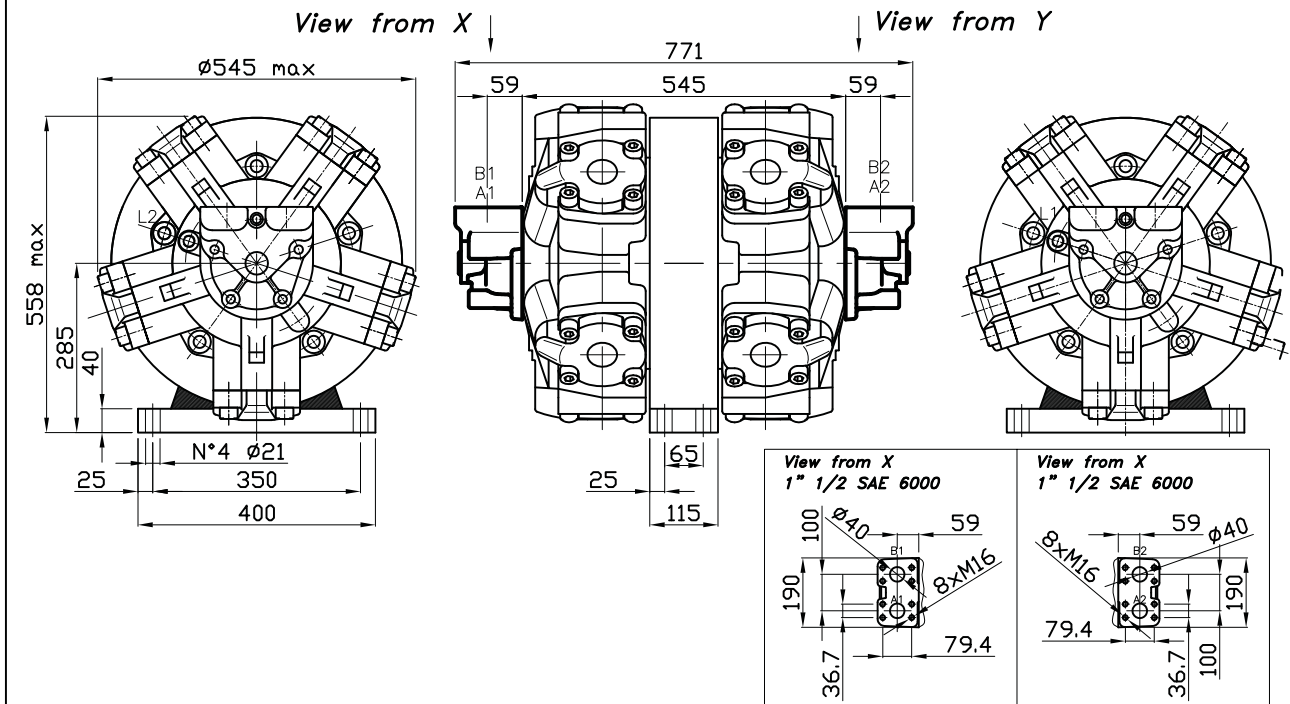

TECHNICAL DATA

FD 5 1400-1500-1600 D90

MODEL	Flow per section		Displacement per section cc/Rev	Working pressure			Power per section kW
	l/min (cont)	l/min (max)		continuous bar	intermittent bar	maximum bar	
FD 5 1400	290	340	1376	250	280	300	87
FD 5 1500	320	375	1528	250	280	300	96
FD 5 1600	350	400	1648	250	280	300	105

Flow Divider Symbol
(with 2 sections)

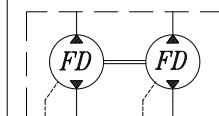

PORTS DIMENSION

L1/L2 1/2" BSP

Dry weight 460 kg

Max case pressure 20 bar

SIZE

FD 5 1400-1500-1600 D90 VB

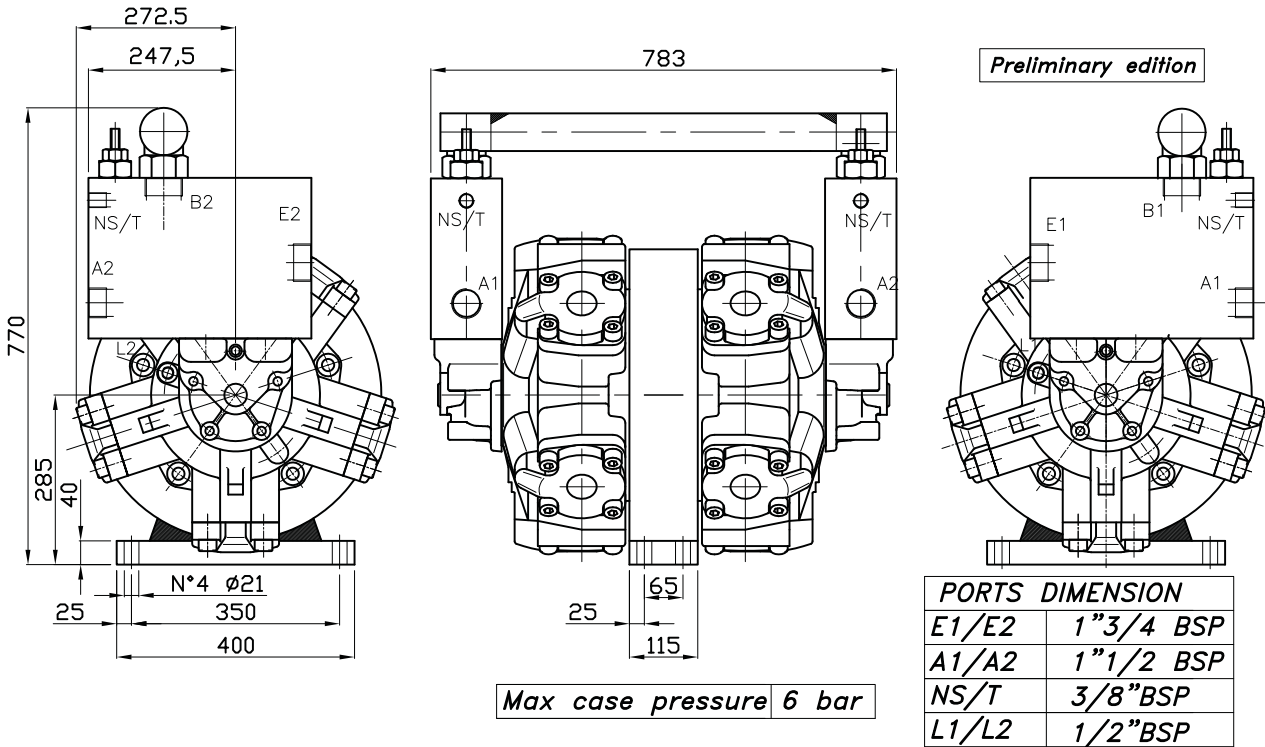

TECHNICAL DATA

FD 5 1400-1500-1600 D90 VB

MODEL	Flow per section		Displacement per section cc/Rev	Working pressure			Power per section kW
	l/min (cont)	l/min (max)		continuous bar	intermittent bar	maximum bar	
FD 5 1400	290	340	1376	250	280	300	87
FD 5 1500	320	375	1528	250	280	300	96
FD 5 1600	350	400	1648	250	280	300	105

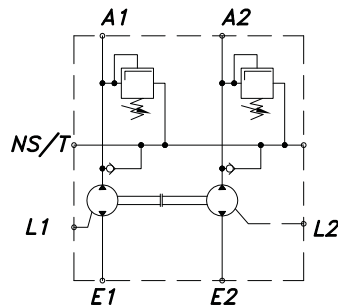
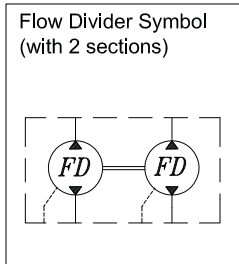

RELIEF VALVE DATA	
Rated flow	40 l/min
Adjustable pressure range	5-50 bar
	30-100 bar
	50-220 bar
	80-350 bar

Dry weight 460 kg

Max case pressure 20 bar

SIZE

FD 6 2500-3000-3200-3500 D90

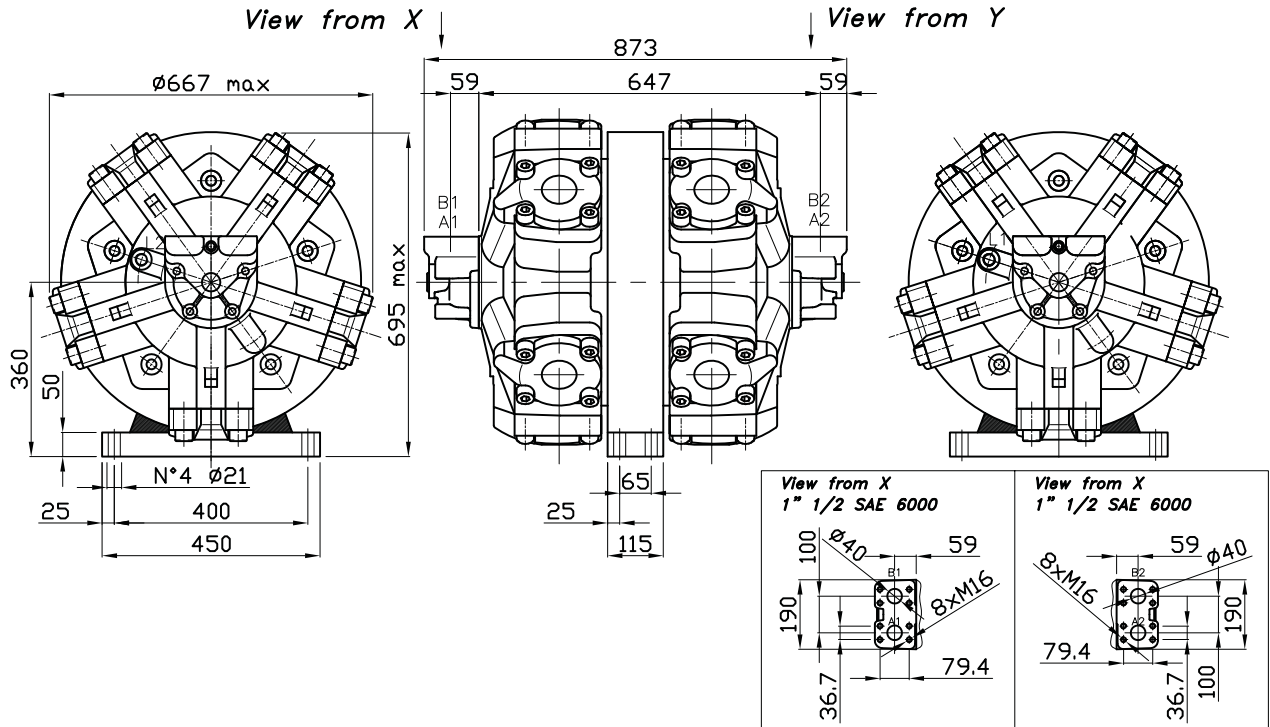

TECHNICAL DATA

FD 6 2500-3000-3200-3500 D90

MODEL	Flow per section		Displacement per section cc/Rev	Working pressure			Power per section kW
	l/min (cont)	l/min (max)		continuous bar	intermittent bar	maximum bar	
FD 6 2500	390	460	2525	250	280	300	118
FD 6 3000	440	525	2983	250	280	300	132
FD 6 3200	460	550	3289	250	280	300	138
FD 6 3500	490	590	3479	250	280	300	147

Flow Divider Symbol
(with 2 sections)

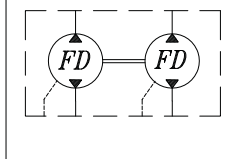

PORTS DIMENSION

L1/L2 3/4" BSP

Dry weight 900 kg

Max case pressure 20 bar

SIZE

FD 6 2500-3000-3200-3500 D90 VB

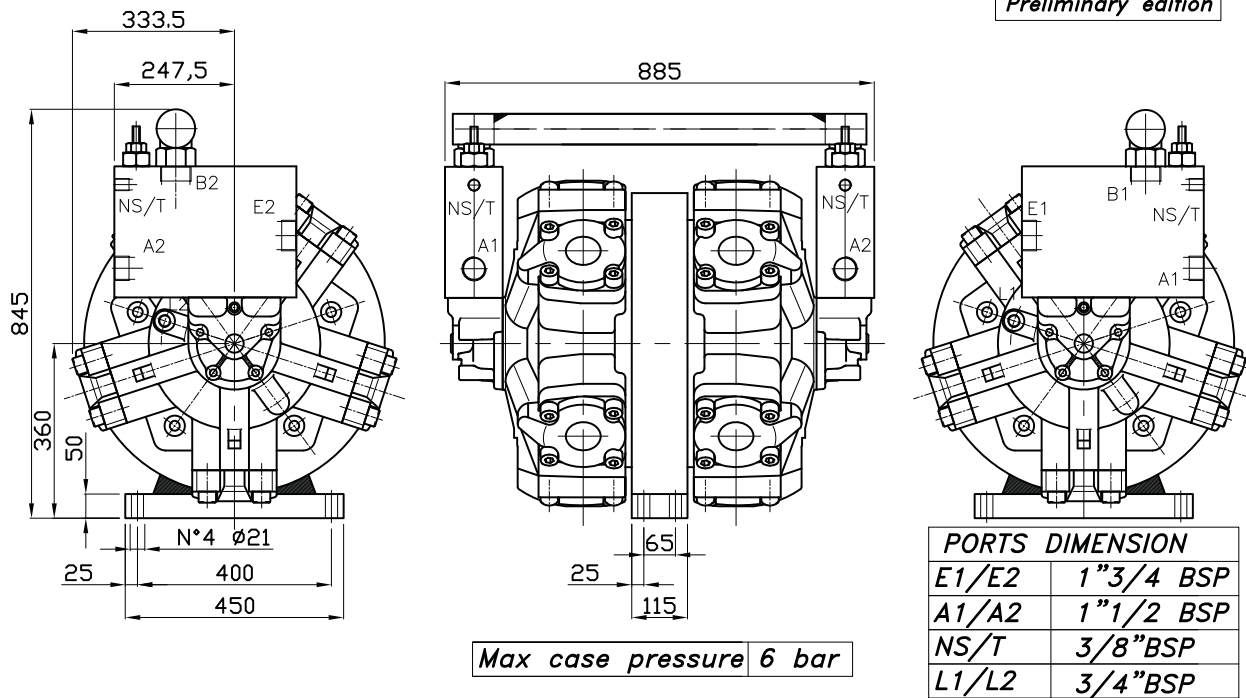

TECHNICAL DATA

FD 6 2500-3000-3200-3500 D90 VB

MODEL	Flow per section		Displacement per section cc/Rev	Working pressure			Power per section kW
	l/min (cont)	l/min (max)		continuous bar	intermittent bar	maximum bar	
FD 6 2500	390	460	2525	250	280	300	118
FD 6 3000	440	525	2983	250	280	300	132
FD 6 3200	460	550	3289	250	280	300	138
FD 6 3500	490	590	3479	250	280	300	147

Flow Divider Symbol
(with 2 sections)

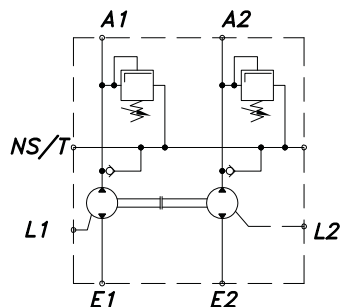
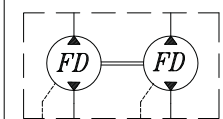

RELIEF VALVE DATA

Rated flow	40 l/min
Adjustable pressure range	5-50 bar
	30-100 bar
	50-220 bar
	80-350 bar

Dry weight 900 kg

Max case pressure 20 bar

SIZE

FDM 34 D21

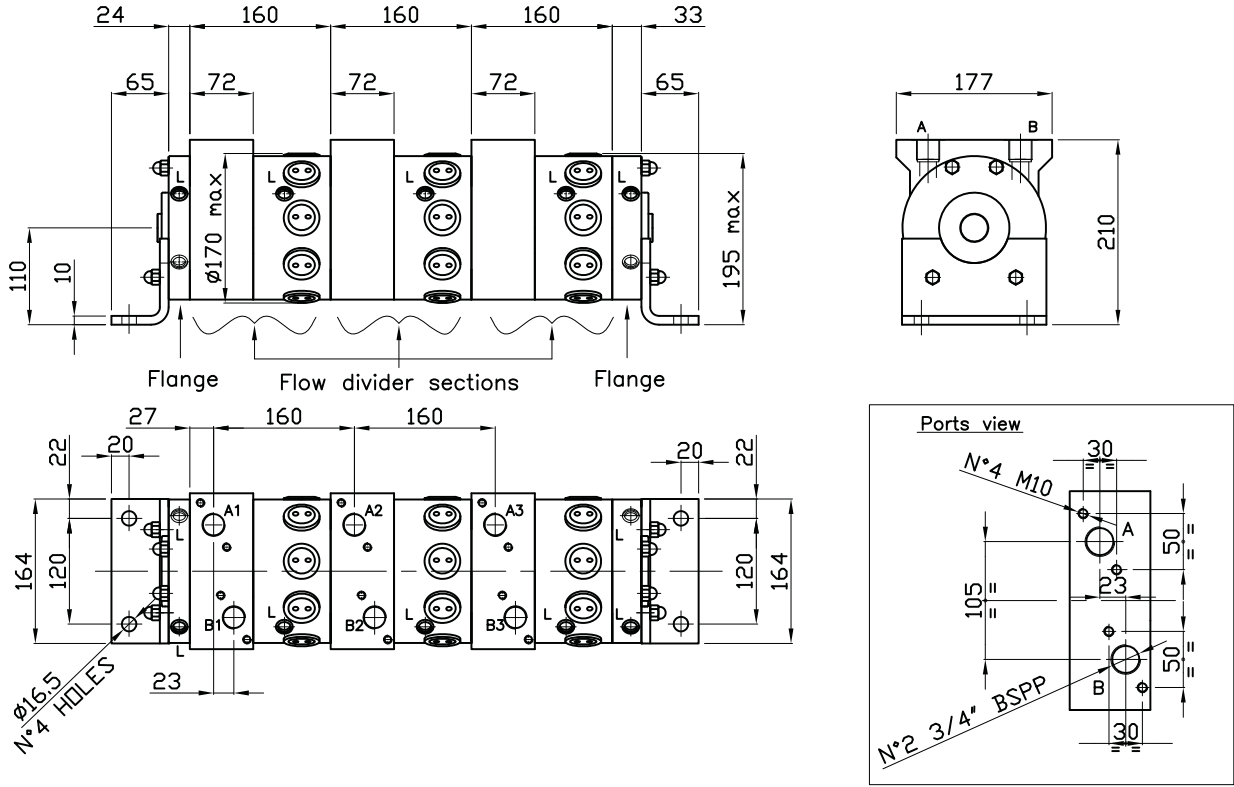

TECHNICAL DATA

FDM 34 D21

MODEL	Flow per section		Displacement per section cc/Rev	Working pressure			Power per section kW
	l/min (cont)	l/min (max)		continuous bar	intermittent bar	maximum bar	
FDM34	45	60	34	250	280	320	15

HYDRAULIC SCHEME

PORTS DIMENSION	
A1,A2,...	3/4" BSPP
B1,B2,...	3/4" BSPP
L	1/4" BSPP

The drain ports (L) are internally connected together. At least one of these drain ports must be connected to the tank. For continuous use, flushing is required.

max case pressure	20 bar
dry weight per section	32 kg

SIZE

FDM 34 D21 VB

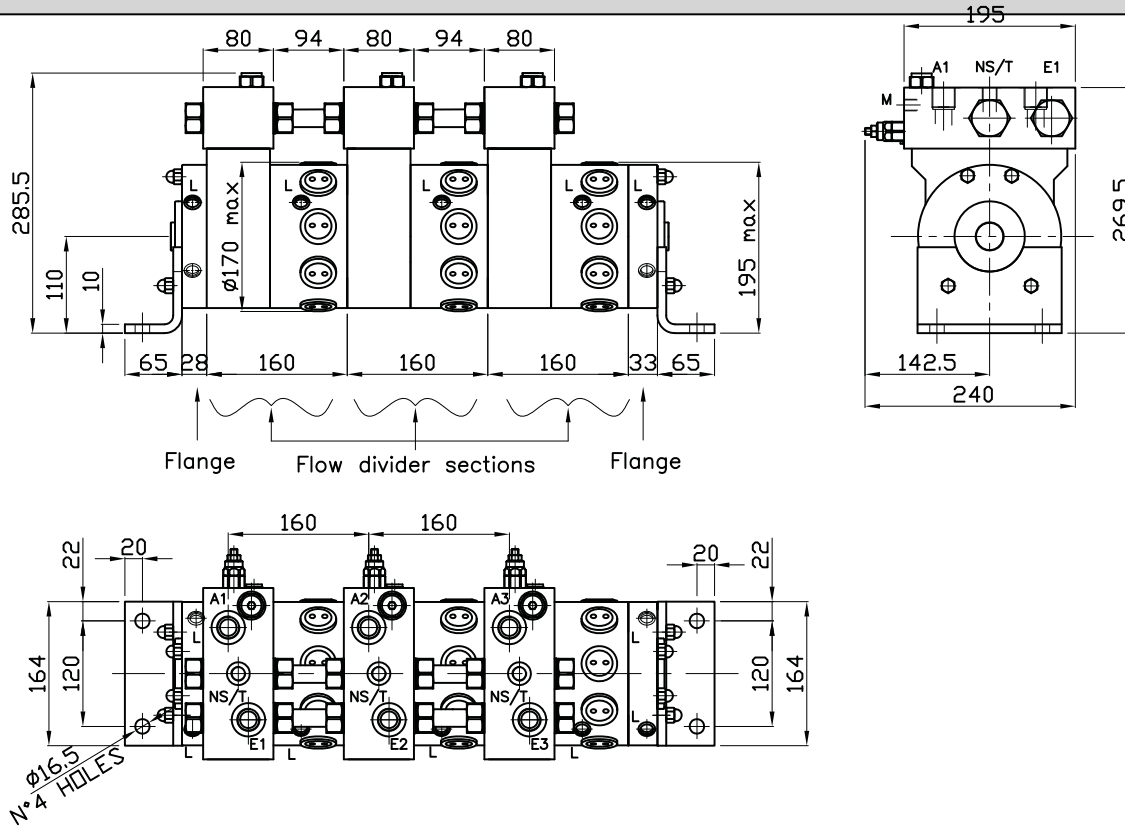

TECHNICAL DATA

FDM 34 D21 VB

MODEL	Flow per section		Displacement per section cc/Rev	Working pressure			Power per section kW
	l/min (cont)	l/min (max)		continuous bar	intermittent bar	maximum bar	
FDM34	45	60	34	250	280	320	15

PORTS DIMENSION	
A1,A2,...	3/4" BSPP
E1,E2,...	1" BSPP
M1,M2,...	1/4" BSPP
L	1/4" BSPP
NS/T	3/8" BSPP

max case pressure	20 bar
dry weight per section	35 kg

Refer to page 29 for valve technical data, valve dimensions and hydraulic circuit.

SIZE

FDM 50-75-100 D21

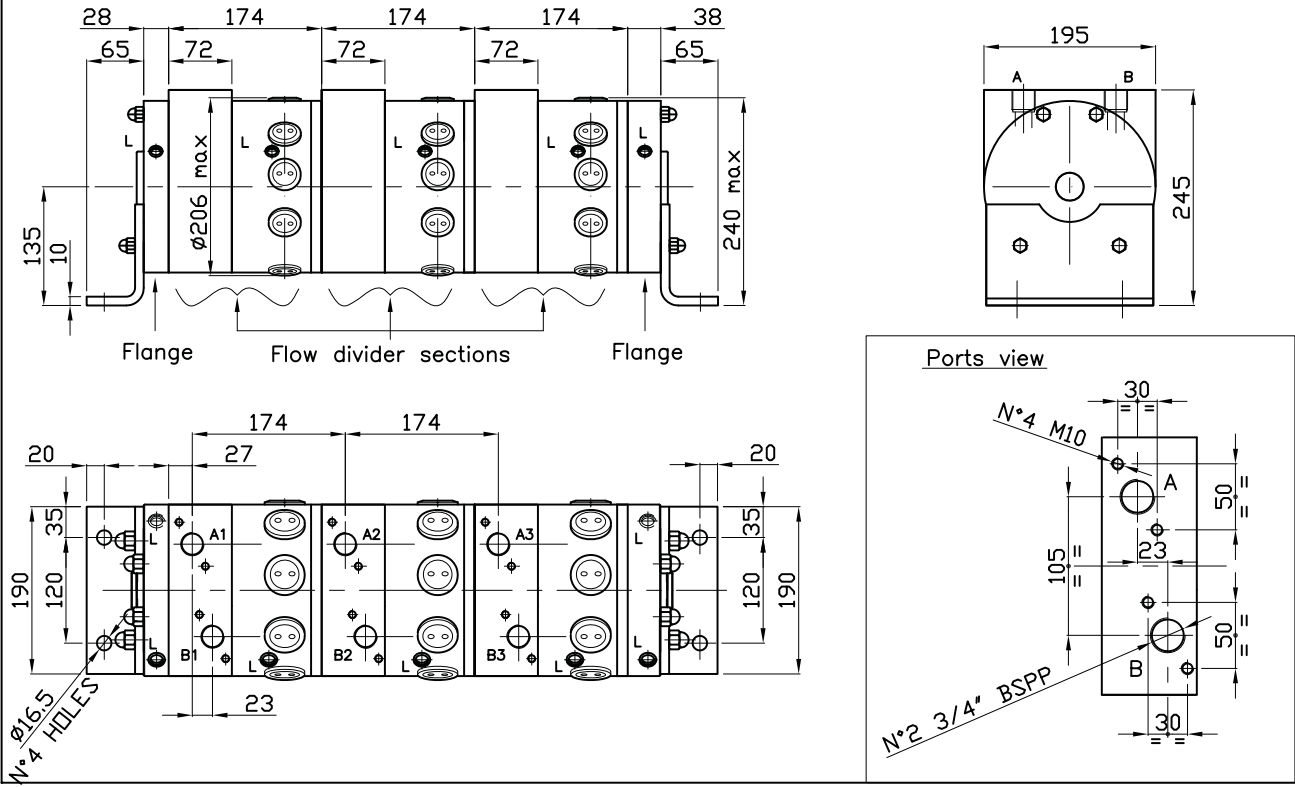

TECHNICAL DATA

FDM 50-75-100 D21

MODEL	Flow per section		Displacement per section cc/Rev	Working pressure			Power per section kW
	l/min (cont)	l/min (max)		continuous bar	intermittent bar	maximum bar	
FDM50	60	80	51	250	280	320	20
FDM75	90	120	76	250	280	320	35
FDM100	125	160	102	250	280	320	40

HYDRAULIC SCHEME

PORTS DIMENSION	
A1,A2,...	3/4" BSPP
B1,B2,...	3/4" BSPP
L	3/8" BSPP

max case pressure	20 bar
dry weight per section	42 kg

The drain ports (L) are internally connected together. At least one of these drain ports must be connected to the tank. For continuous use, flushing is required.

SIZE

FDM 50-75-100 D21 VB

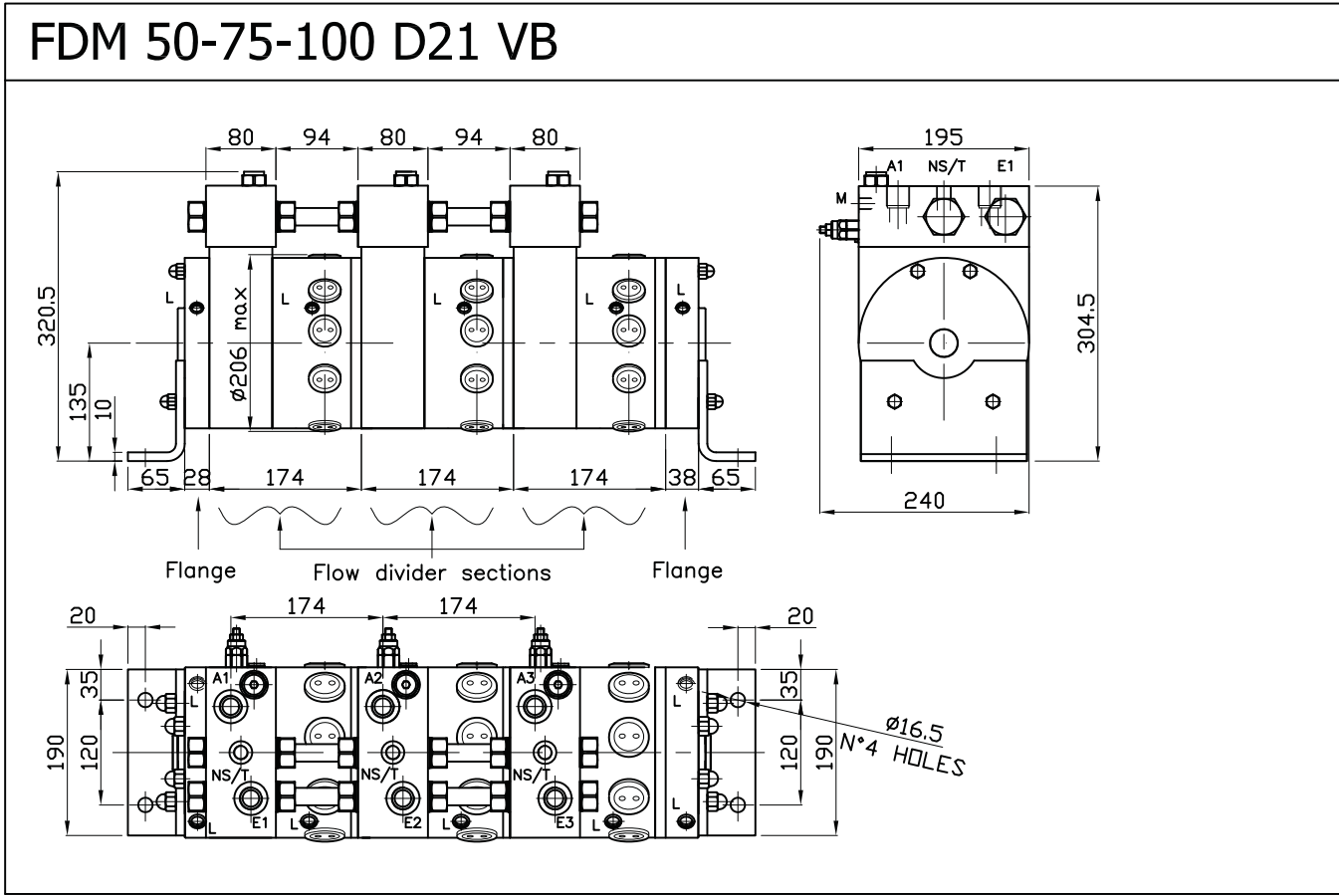

TECHNICAL DATA

FDM 50-75-100 D21 VB

MODEL	Flow per section		Displacement per section cc/Rev	Working pressure			Power per section kW
	l/min (cont)	l/min (max)		continuous bar	intermittent bar	maximum bar	
FDM50	60	80	51	250	280	320	20
FDM75	90	120	76	250	280	320	35
FDM100	125	160	102	250	280	320	40

PORTS DIMENSION	
A1,A2,...	3/4" BSPP
E1,E2,...	1" BSPP
M1,M2,...	1/4" BSPP
L	3/8" BSPP
NS/T	3/8" BSPP

max case pressure	20 bar
dry weight per section	45 kg

Refer to page 29 for valve technical data, valve dimensions and hydraulic circuit.

VALVE DIMENSIONS AND TECHNICAL DATA

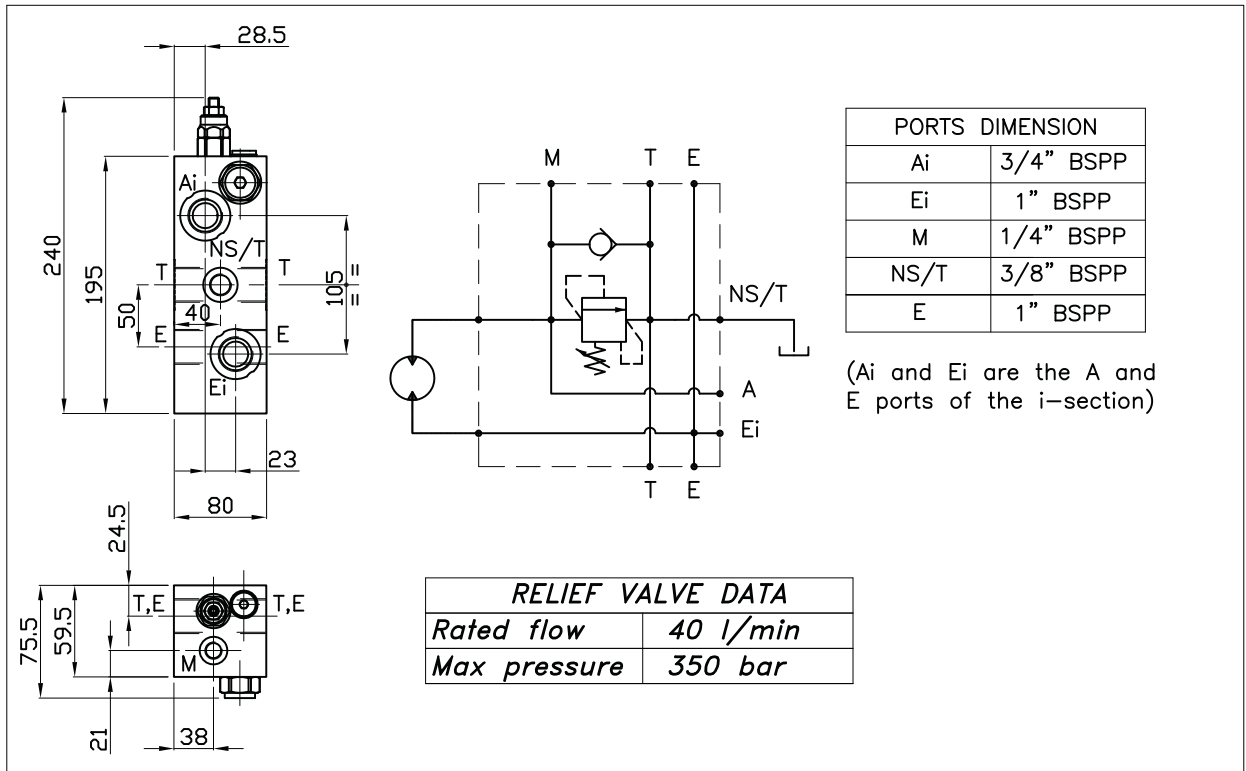

HYDRAULIC CIRCUIT

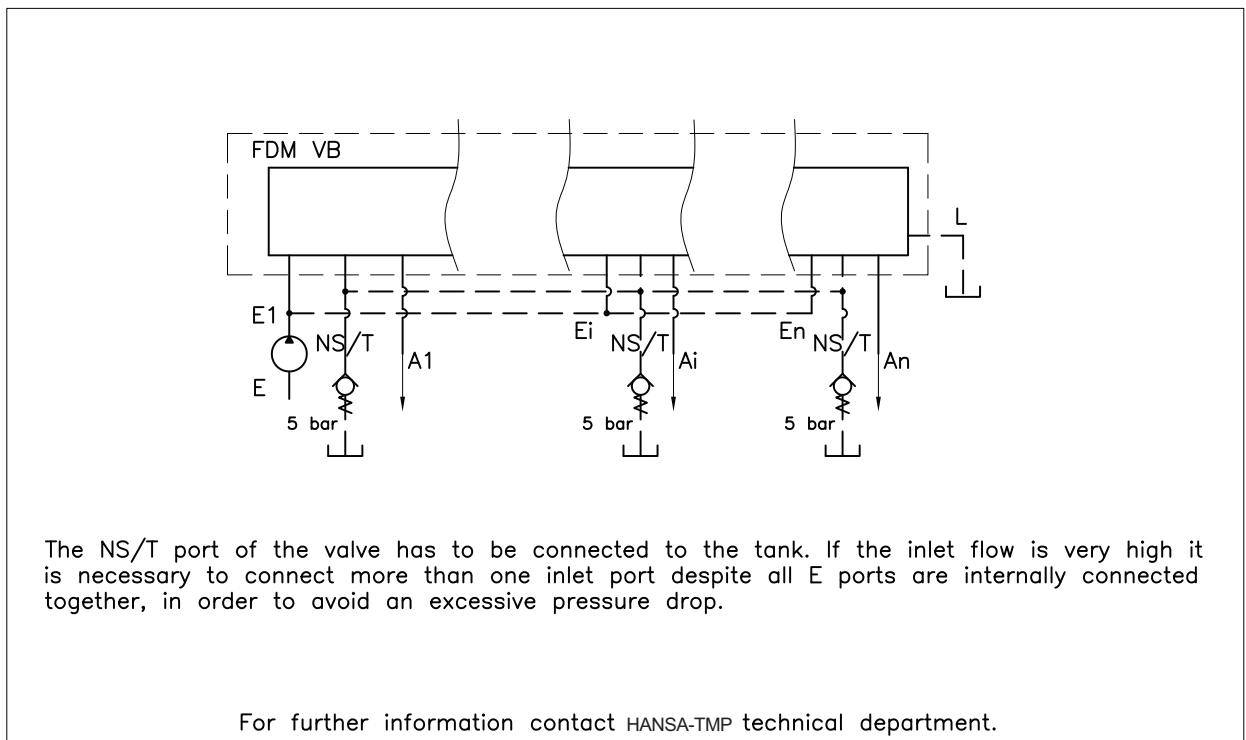

FD SERIES - ORDERING INSTRUCTIONS

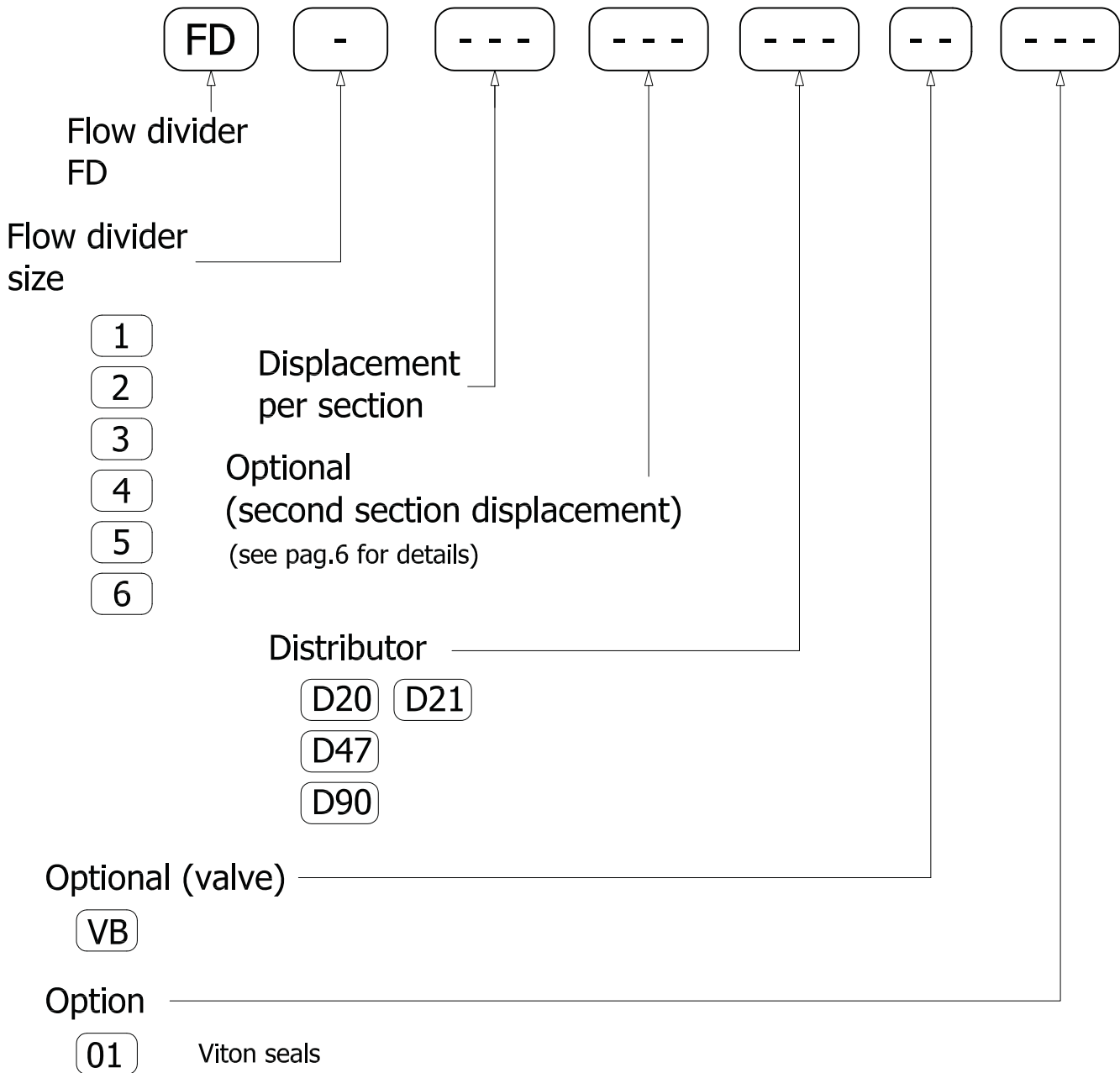

EXAMPLE: FD.27.D20
FD.1.150.D47.VB
FD.5.1500.D90
FD.20.34.D21.VB.01

FDM SERIES - ORDERING INSTRUCTIONS

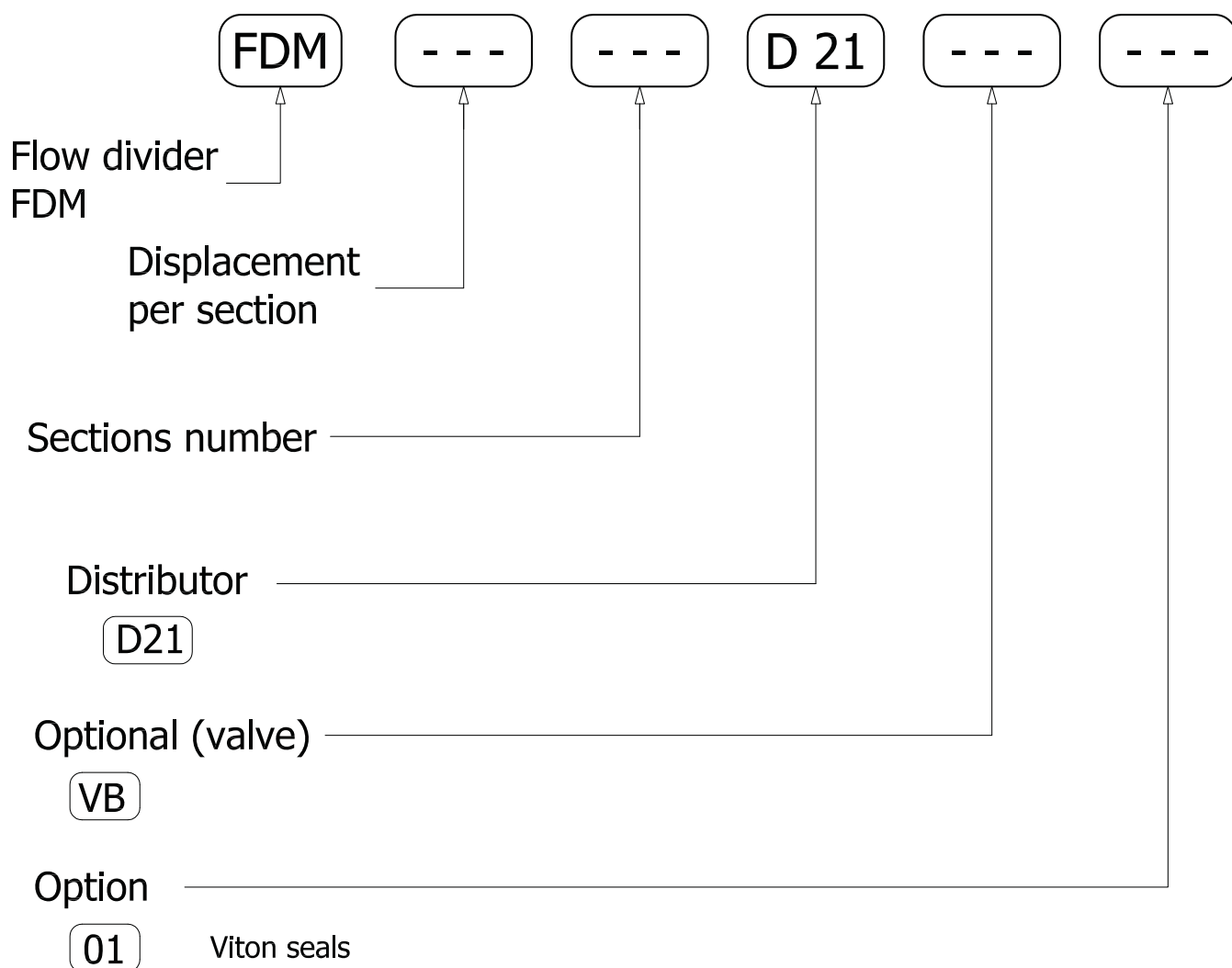

EXAMPLE: FDM.50-4.D21.VB
 FDM.75-3.D21
 FDM.100-4.D21
 FDM.100-4.D21.01

Flow dividers selection chart

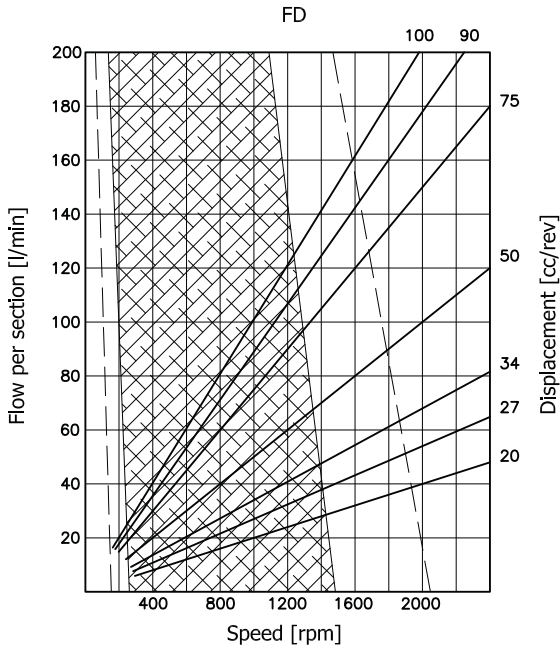

Flow dividers selection chart

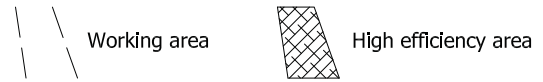
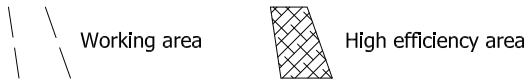
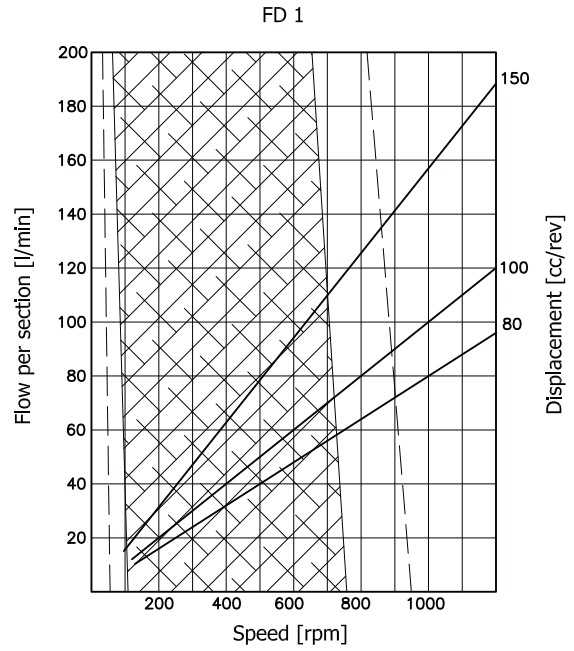

Flow dividers selection chart

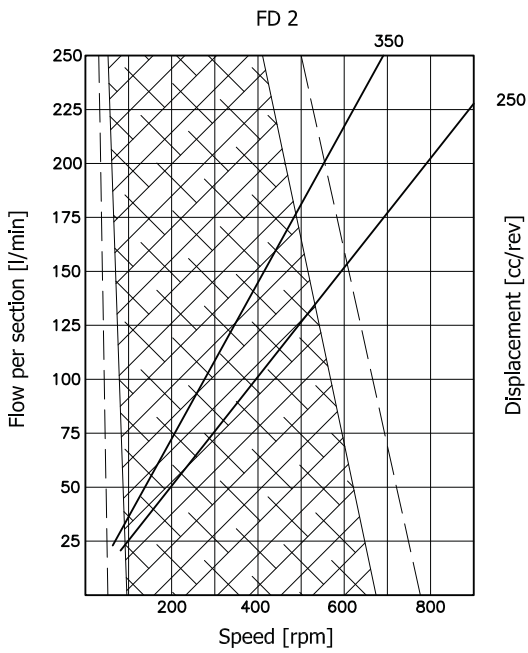

Flow dividers selection chart

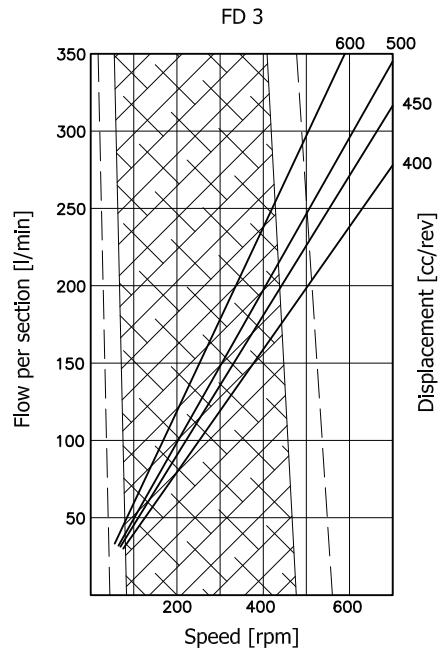

Flow dividers selection chart

FD 4

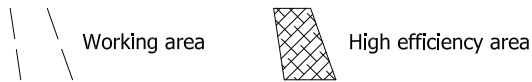
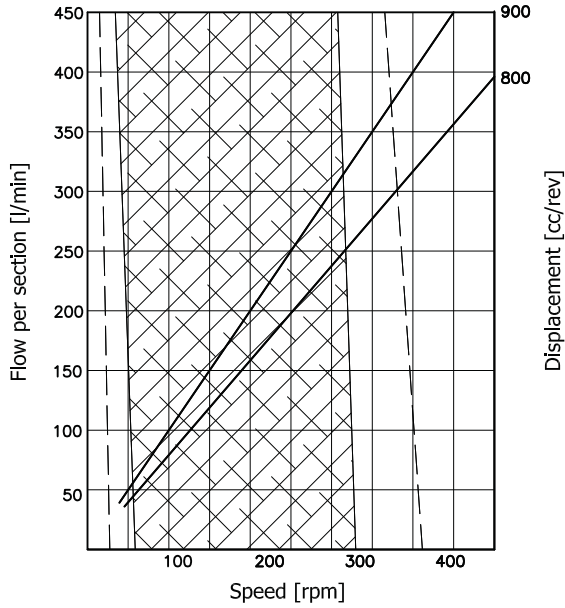

Flow dividers selection chart

FD 5

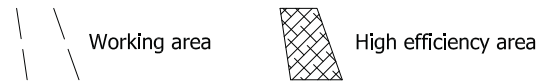
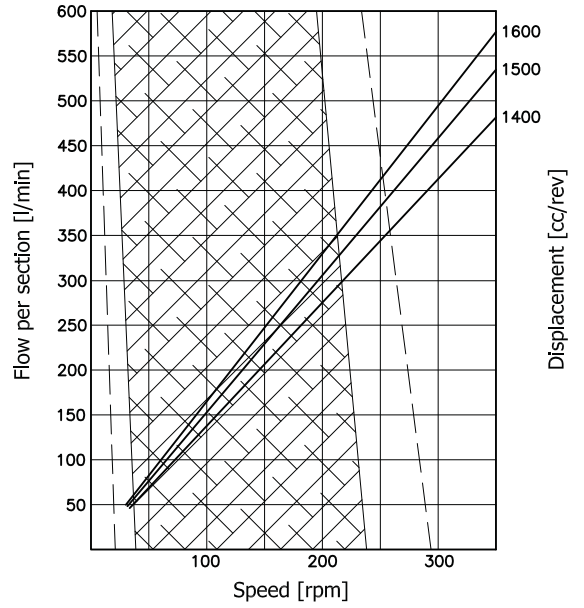

Flow dividers selection chart

FD 6

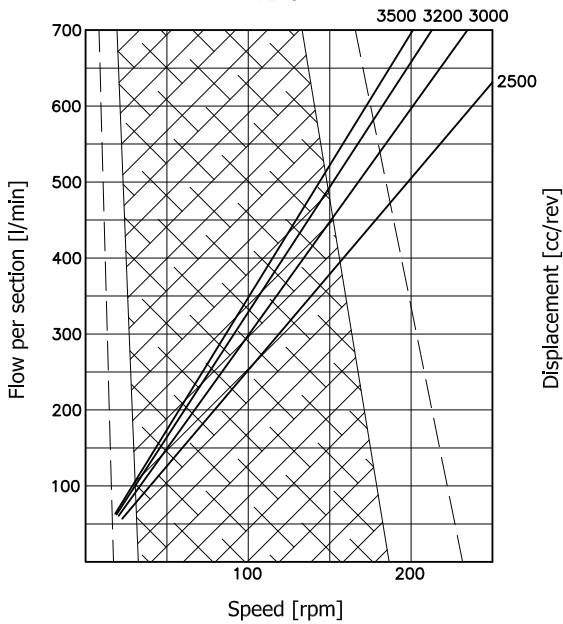

Flow dividers selection chart

FDM

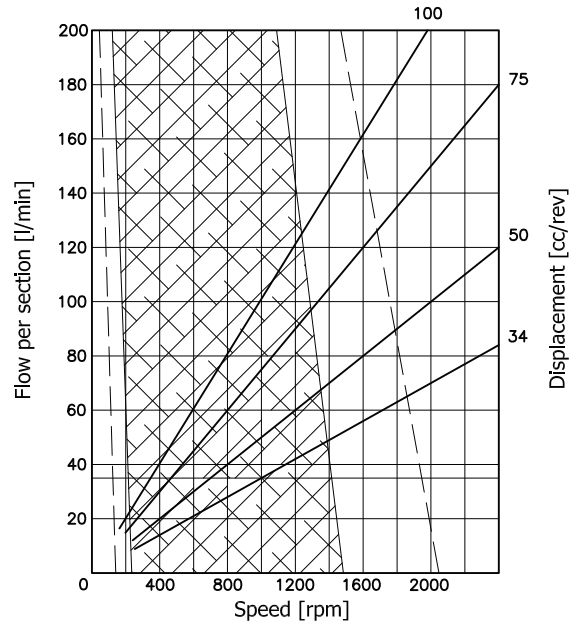

As HANSA-TMP has a very extensive range of products and some products have a variety of applications, the information supplied may often only apply to specific situations. If the catalogue does not supply all the information required, please contact HANSA-TMP.

In order to provide a comprehensive reply to queries we may require specific data regarding the proposed application.

Whilst every reasonable endeavour has been made to ensure accuracy this publication cannot be considered to represent part of any contract, whether expressed or implied.

HANSA-TMP reserves the right to amend specifications at their discretion.



Dutch Hydraulic Consultants BV	Tel. : +31-(0)6-83695868
Achterweg ZZ 8	Mail : info@dhc-hydraulic.nl
3216 AB Abbenbroek	Web : www.dhc-hydraulic.nl
Nederland	