



Slewing Rings



Index

General Information.....	4
EXTERNAL GEAR SLEWING RINGS - 1 Row of balls.....	5
EXTERNAL GEAR SLEWING RINGS - 2 Rows of balls.....	6
EXTERNAL GEAR SLEWING RINGS - 1 Row of rolls.....	7
INTERNAL GEAR SLEWING RINGS - 1 Row of balls.....	8
INTERNAL GEAR SLEWING RINGS - 2 Rows of balls.....	9
INTERNAL GEAR SLEWING RINGS - 1 Row of rolls.....	10
UNGEARED SLEWING RINGS - 1 Row of balls.....	11
UNGEARED SLEWING RINGS - 2 Rows of balls.....	12
UNGEARED SLEWING RINGS - 1 Row of rolls.....	13

General Information

SLEWING RINGS

Product available in numerous versions and dimensions.

From an external diameter of 300 mm up to 2100 mm and in versions with external or internal gears or with no gears. In addition, according to the type of load, they are available with 1 row of balls, 2 rows of balls and one row of rollers. Materials available according to requirements and in line with market standards.

Applications:

- Atomizers
- Snow-maker
- Dumpers
- Semi-industrial systems
- Irrigators
- Agricultural trailers
- Ladders on vehicles
- Trolleys



EXTERNAL GEAR SLEWING RINGS

1 Row of balls

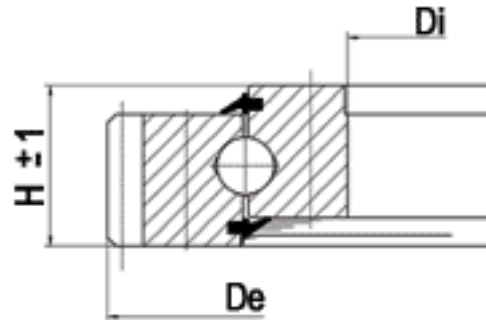

Technical Information

External Gear Slewing Rings - 1 Row of balls								
Code	Ext. Diam. D_e mm.	Int. Diam. D_i mm.	Depth H mm.	Module m	n° of teeth	Weight kg	Max. Axial Load F_a kN	Max. Bending Moment M_r kNm
VE030A00	305	156	55	2,5	120	17,5	500	25
VE031A01	318	156	55	4,5	69	17,5	510	23
VE040A01	403,5	235	55	4,5	88	25	700	43
VE043A05	434	265	50	5	85	30	780	54
VE045A00	455,4	285	55	4,5	98	29	820	60
VE050A10	503,3	344	56	5	99	31	960	80
VE050A02	503,3	344	56	5	99	31	960	80
VE059A22	589,5	383	75	4,5	129	62	1350	126
VE059A00	595	381	65	5	117	58	1150	105
VE059A10	595	381	65	5	117	58	1100	105
VE064A00	640	471	56	6	105	45	1350	118
VE064A07	642	434	58	6	105	40	1280	158
VE079A00	792	570	65	6	130	92	1570	235
VE084A01	840	634	56	6	138	70	1720	290
VE086A00	864	678	65	6	142	83	1790	260
VE097A00	972	764	70	6	160	114	2500	420
VE114A05	1144	869	100	10	111	214	3450	680
VE120A01	1200	976	65	8	148	142,5	2550	545
VE120A05	1200	976	65	8	148	142,5	2550	545
VE140A01	1408	1143	79	10	138	213	3700	1020
VE180A00	1803,2	1466	94	14	126	479	7700	2800

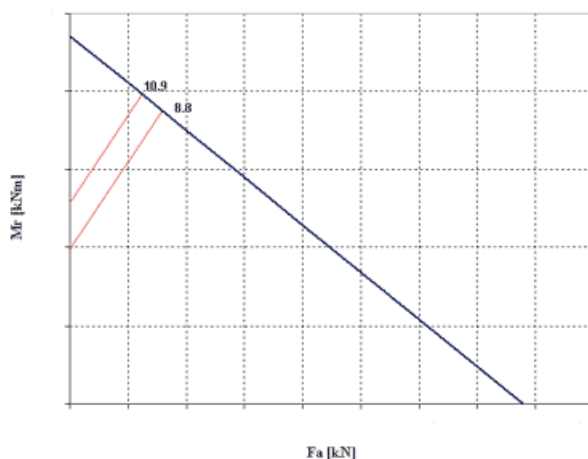

The value of bending moment M_r is inversely proportional to the axial load F_a .

(Ask for specific diagram of each model).

EXTERNAL GEAR SLEWING RINGS

2 Rows of balls

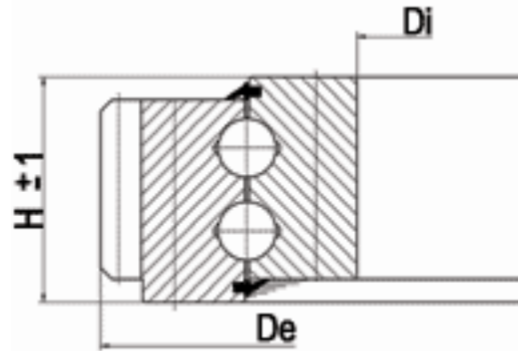

Technical Information

External Gear Slewing Rings - 2 Rows of balls								
Code	Ext. Diam. De mm.	Int. Diam. Di mm.	Depth H mm.	Module m	n° of teeth	Weight kg	Max. Axial Load Fa kN	Max. Bending Moment Mr kNm
VE050B01	504	299	92	8	61	64	1320	108
VE061B00	610	390	90	6	100	98	1320	145
VE086B03	864	670	92	6	142	110	2100	350
VE098B00	979	718	102	10	94	208	2750	520
VE108B03	1080	893	92	8	133	157	3100	690
VE114B00	1144	860	107	10	111	267	3500	780
VE120B12	1200	976	98	8	148	210	3600	890
VE120B01	1200	976	98	8	148	210	3600	890
VE120B00	1200	976	98	8	148	210	3600	890
VE122B00	1218	976	98	10	120	211	3650	900
VE129B00	1289,5	985	110	10	125	340	3900	1000
VE138B05	1380	1095	108	10	136	350	4100	1180
VE138B04	1380	1095	108	10	136	350	4100	1180
VE147B01	1474	1085	110	12	120	503	5400	1560
VE147B03	1476	1085	110	10	144	503	5400	1560
VE160B04	1594	1208	144	12	130	700	7800	2500
VE160B00	1604	1208	144	10	158	698	7800	2500
VE163B01	1634	1208	148	14	113	800	7800	2500

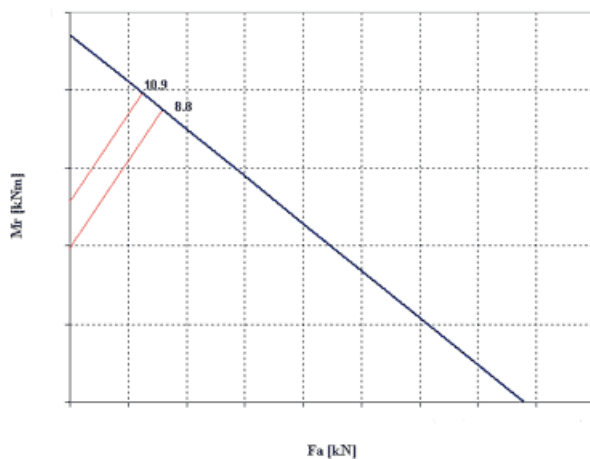

The value of bending moment Mr is inversely proportional to the axial load Fa.

(Ask for specific diagram of each model).

EXTERNAL GEAR SLEWING RINGS

1 Row of roller

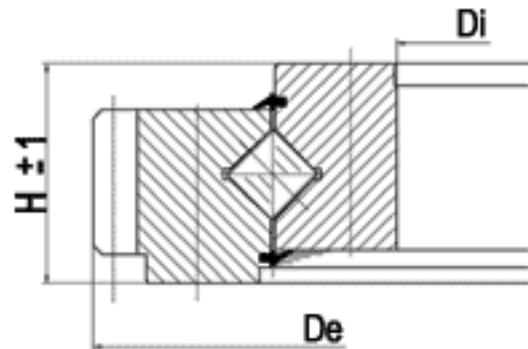

Technical Information

External Gear Slewing Rings - 1 Row of rolls								
Code	Ext. Diam. De mm.	Int. Diam. Di mm.	Depth H mm.	Module m	n° of teeth	Weight kg	Max. Axial Load Fa kN	Max. Bending Moment Mr kNm
V18E089	403,5	234	55	4,5	88	25	790	49
V25E139	535	305	75	8	65	62	1400	112
V18E083	589,5	378	75	4,5	129	58	1350	126
V25E013	595	382	85	5	117	76	1700	160
V18E082	695	477	77	5	137	85	1460	165
V25E195	695	470	85	5	136	97	2000	235
V30E081	816	570	90	8	100	118	2800	370
V25E197	816	571	90	6	132	118	2400	320
V25E248	838	573	90	10	81	132	2400	320
V25E131	864	670	82	6	142	109	2700	415
V30E150	979	718	100	10	94	180	3500	580
V25E062	1080	893	82	8	133	129	3500	690
V30E013	1144	870	100	10	111	232	4200	810
V25E250	1204	976	98	10	118	218	3800	820
V30E088	1289,5	984	114	10	125	335	4800	1080
V30E123	1378	1095	90	10	136	260	5100	1260
V30E087	1476	1085	122	10	144	450	5350	1340
V30E151	1476	1085	110	10	144	475	5350	1340
V40E028	1604	1206	130	10	157	698	7900	2200
V40E027	1829	1430	145	12	150	861	8500	2900
V40E029	1943,2	1529	100	14	136	691	9700	3300

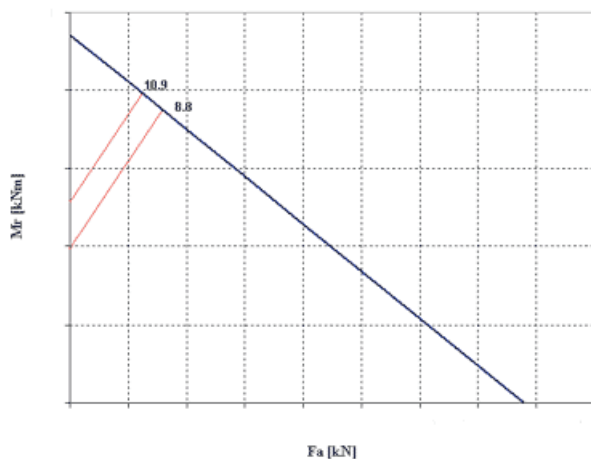

The value of bending moment Mr is inversely proportional to the axialload Fa.

(Ask for specific diagram of each model).

INTERNAL GEAR SLEWING RINGS

1 Row of balls

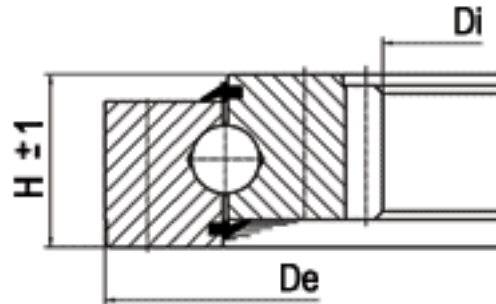

Technical Information

Internal Gear Slewing Rings - 1 Row of balls								
Code	Ext. Diam. De mm.	Int. Diam. Di mm.	Depth H mm.	Module m	n° of teeth	Weight kg	Max. Axial Load Fa kN	Max. Bending Moment Mr kNm
VI040A01	400	216	55	4	56	26,5	700	43
VI053A00	535	374	50	6	63	35	1180	126
VI057A01	570	378	63	6	65	51,5	1160	115
VI064A05	642	471	55	5	96	47	1310	150
VI075A00	750	546	63	6	93	76	1560	210
VI085A05	850	648	63	6	110	86,5	2200	330
VI085A08	850	648	63	6	110	86,5	2200	330
VI095A01	950	736	63	8	94	101,5	2200	370
VI095A14	950	736	63	8	94	101,5	2200	370
VI100A00	1000	723	80	8	91	97,5	3650	720
VI104A04	1048	844	56	8	107	89	2300	440
VI105A03	1050	840	82	8	107	141,5	3350	650
VI105A04	1050	840	82	8	107	141,5	3350	650
VI129A00	1298	1014	90	10	103	256	3400	900
VI142A01	1427	1184	89	8	150	260	4300	1020
VI147A00	1470	1183	108	10	120	381	4800	1280
VI160A01	1600	1310	90	10	133	295	5100	1550
VI200A01	2000	1680	89	10	170	515	6700	2900

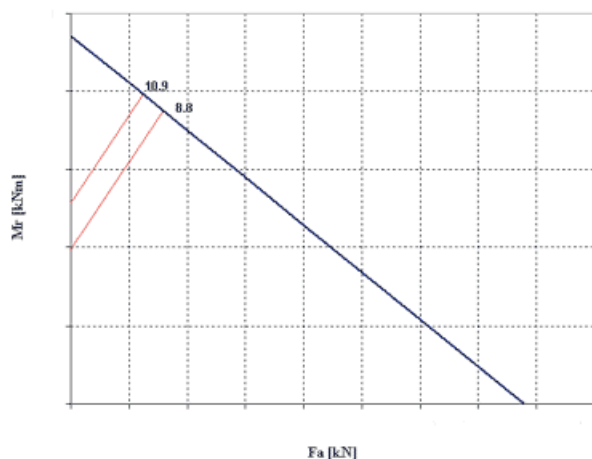

The value of bending moment M_r is inversely proportional to the axial load F_a .

(Ask for specific diagram of each model).

INTERNAL GEAR SLEWING RINGS

2 Rows of balls

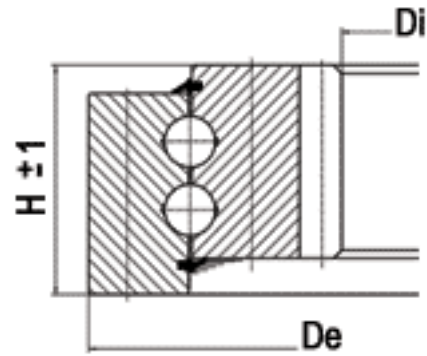

Technical Information

Internal Gear Slewing Rings - 2 Rows of balls								
Code	Ext. Diam. De mm.	Int. Diam. Di mm.	Depth H mm.	Module m	n° of teeth	Weight kg	Max. Axial Load Fa kN	Max. Bending Moment Mr kNm
VI057B02	570	368	84	8	48	77	1310	146
VI085B00	850	640	92	8	81	127	2100	370
VI095B01	950	738	92	8	92	158	2350	465
VI097B06	976	786	97	8	100	153	2450	510
VI098B03	982	754	97	8	95	170	3600	720
VI101B00	1015	771	110	10	78	207	3750	790
VI107B01	1074	820	114	10	84	235	4000	890
VI117B06	1172	962	97	10	98	202	2800	700
VI117B01	1172	962	97	10	98	202	2800	700
VI120B01	1200	963,5	110	10	98	247	4500	1170
VI120B00	1200	963,5	110	10	98	247	4500	1170
VI125B01	1250	998	110	10	100	282	4400	1170
VI134B00	1345	1062	108	10	108	337	5400	1480
VI147B02	1470	1182	108	10	120	394	5100	1600
VI147B01	1470	1179	108	12	100	394	5900	1800
VI153B06	1530	1188	144	10	120	620	6800	2150
VI153B03	1530	1179	144	12	100	620	6800	2150
VI175B03	1750	1419	120	12	120	600	7400	2600

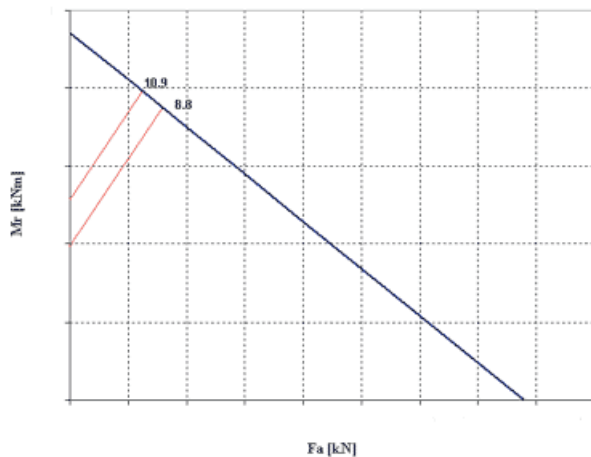

The value of bending moment Mr is inversely proportional to the axialload Fa.

(Ask for specific diagram of each model).

INTERNAL GEAR SLEWING RINGS

1 Row of roller

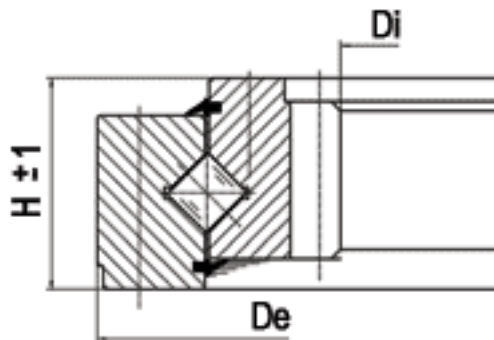

Technical Information

Internal Gear Slewing Rings - 1 Row of rolls								
Code	Ext. Diam. De mm.	Int. Diam. Di mm.	Depth H mm.	Module m	n° of teeth	Weight kg	Max. Axial Load Fa kN	Max. Bending Moment Mr kNm
V18I082	562	384,6	60	6	66	44	1220	120
V18I089	665	457	60	6	77	75	1480	170
V25I185	695	446	85	6	76	75	2050	235
V25I001	750	546	82	6	93	98	2350	310
V25I192	815	593	80	8	76	110	2550	360
V25I161	976	786	82	8	100	124	3150	560
V25I040	1170	962	90	10	98	177	3600	820
V30I132	1200	963,5	108	10	98	248	4700	1020
V30I013	1345	1066	108	10	108	311	5200	1260

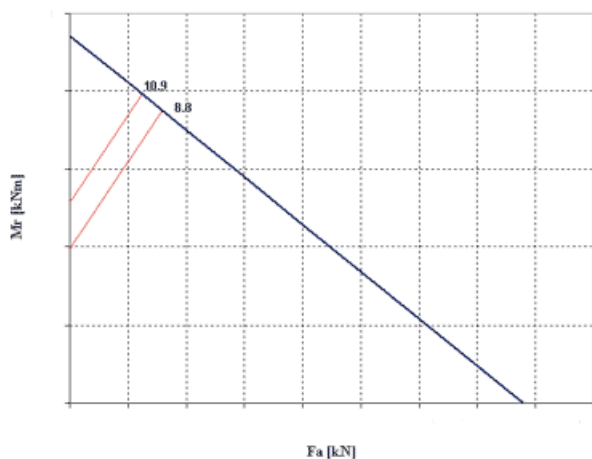

The value of bending moment Mr is inversely proportional to the axial load Fa.

(Ask for specific diagram of each model).

UNGEARED SLEWING RINGS

1 Row of balls

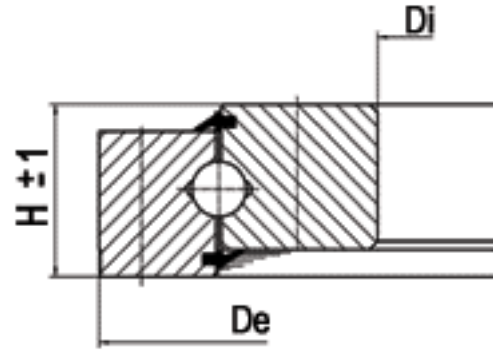

Technical Information

Ung geared Slewing Rings - 1 Row of balls						
Code	Ext. Diam. D_e mm.	Int. Diam. D_i mm.	Depth H mm.	Weight kg	Max. Axial Load F_a kN	Max. Bending Moment M_r kNm
VS040A00	403,5	235	55	25	700	43
VS048A00	486	308	70	48,5	1100	100
VS051A03	518	304	56	49	580	48
VS064A08	650	432	56	63	1260	136
VS094A00	948	734	56	97,5	1840	315

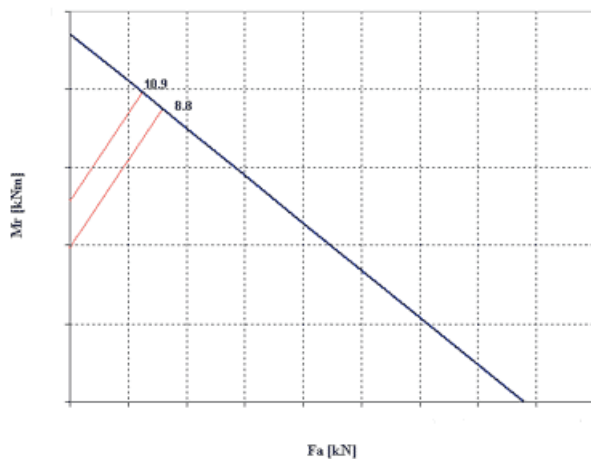

The value of bending moment M_r is inversely proportional to the axial load F_a .

(Ask for specific diagram of each model).

UNGEARED SLEWING RINGS

2 Rows of balls

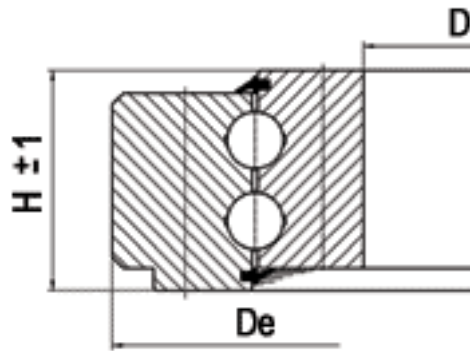

Technical Information

Ung geared Slewing Rings - 2 Rows of balls						
Code	Ext. Diam. De mm.	Int. Diam. Di mm.	Depth H mm.	Weight kg	Max. Axial Load Fa kN	Max. Bending Moment Mr kNm
VS050B00	504	299	92	64	1330	118
VS061B00	610	390	90	98	1330	146
VS098B00	979	718	102	208	2750	520

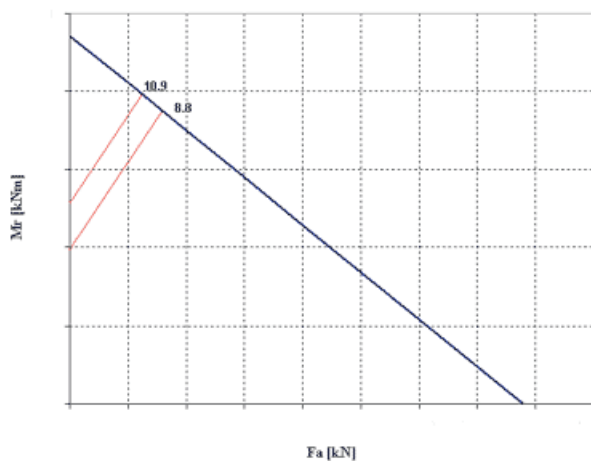

The value of bending moment M_r is inversely proportional to the axial load F_a .

(Ask for specific diagram of each model).

UNGEARED SLEWING RINGS

1 Row of roller

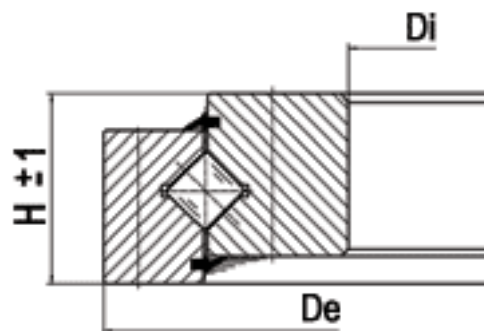

Technical Information

Ung geared Slewing Rings - 1 Row of rolls						
Code	Ext. Diam. De mm.	Int. Diam. Di mm.	Depth H mm.	Weight kg	Max. Axial Load Fa kN	Max. Bending Moment Mr kNm
V18S077	403,5	234	55	24	780	48
V25S084	500	305	75	52	1400	116
V18S080	562	384,5	60	44	1240	120
V18S074	589,5	378	75	58	1320	126
V18S084	695	479	77	75	1460	170
V25S085	816	571	90	120	2200	320
V25S091	864	670	82	109	2700	420
V30S018	979	718	100	180	3500	580
V30S023	1345	1066	108	311	5150	1260

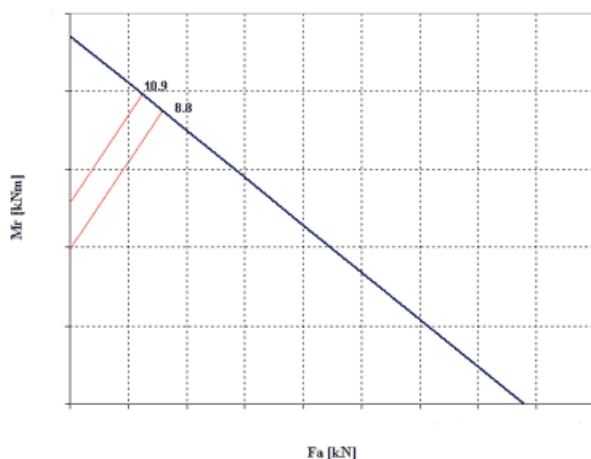

The value of bending moment M_r is inversely proportional to the axial load F_a .

(Ask for specific diagram of each model).

**HYDRAULIC COMPONENTS
HYDROSTATIC TRANSMISSIONS
GEARBOXES - ACCESSORIES**

Fill only field with blue background

SLEW RING ENQUIRY FORM

From			
Company			
Street			
City		ZIP	
Telephone			
Fax			
E-Mail			

Please compile this page and send by fax or E-mail to:

Dutch Hydraulic Consultants BV
 Achterweg ZZ 8
 3216 AB Abbenbroek
 Tel.: 06-83695868
 Mail : info@dhc-hydraulic.nl

Date

Application Machine model

ROTATION

Positioning..... Continued.....
 Rotation Speed.....n/min.

ROTATION AXLE POSITION

Horizontal..... Vertical.....

LOAD DIRECTION

Compression..... Traction.....
 Working temperature°C Work Environment.....

LOAD BEARING

Axial Load.....N Radial Load.....N
 Bending Moment.....Nm Torque of teeth.....Nm

DIMENSIONS REQUIRED

Max. external diameter.....mm.

TEETH

External..... Internal.....
 Without teeth.....

Use condition, duty cycle etc. (describe in detail)

Notes

As HANSA-TMP has a very extensive range of products and some products have a variety of applications, the information supplied may often only apply to specific situations. If the catalogue does not supply all the information required, please contact HANSA-TMP.

In order to provide a comprehensive reply to queries we may require specific data regarding the proposed application.

Whilst every reasonable endeavour has been made to ensure accuracy this publication cannot be considered to represent part of any contract, whether expressed or implied.

HANSA-TMP reserves the right to amend specifications at their discretion.



Dutch Hydraulic Consultants BV	Tel. : +31-(0)6-83695868
Achterweg ZZ 8	Mail : info@dhc-hydraulic.nl
3216 AB Abbenbroek	Web : www.dhc-hydraulic.nl
Nederland	