



# Pump Drives - Gearboxes

## Mechanical Dry Clutches

## Hydraulic Clutches

## Pump Adaptors



**CONTENTS**

<b>Pump Drives AM Series</b>	5 - 51
General Information	6 - 13
<b>AM 110</b> (180 kW)	14 - 17
<b>AM 216</b> (205 kW)	18 - 21
<b>AM 220</b> (355 kW)	22 - 25
<b>AM 230</b> (430 kW)	26 - 29
<b>AM 232</b> (565 kW)	30 - 33
<b>AM 320</b> (205 kW)	34 - 37
<b>AM 330</b> (355 kW)	38 - 41
<b>AM 345</b> (430 kW)	42 - 45
<b>AM 450</b> (640 kW)	46 - 49
<b>AM 365</b> (670 kW)	50
<b>AM 480</b> (700 kW)	51
<b>Speed Reducing (Increasing) Gearboxes RM Series</b>	53 - 60
General Information	54 - 55
Technical Data and Installation Drawings	56 - 60
<b>Mechanical Power Take-off BD* Series</b>	61 - 68
General Information	62
Technical Data and Installation Drawings	62 - 68
<b>Hydraulic Power Take-off PFI Series</b>	69 - 73
<b>PFI 60</b>	70 - 71
<b>PFI 120</b>	72 - 73
<b>Bell Housings and Couplings for Hydraulic Pumps</b>	75 - 82
General Information	76
Flywheel Side Adaptors	77 - 80
ISO Flanges	81
Front Mounting Adaptors	82

# PUMP DRIVES



## MAX INPUT POWER

### SINGLE PUMP DRIVES

AM 110 - 180 kW

### DOUBLE PUMP DRIVES

AM 216 - 205 kW

AM 220 - 355 kW

AM 230 - 430 kW

AM 232 - 565 kW

### TRIPLE PUMP DRIVES

AM 320 - 205 kW

AM 330 - 355 kW

AM 345 - 430 kW

AM 365 - 670 kW

### FOUR PUMP DRIVES

AM 450 - 640 kW

AM 480 - 700 kW

## GENERAL INFORMATION

### CHARACTERISTICS

The pump drives allow the contemporary running of one or more hydraulic pumps from a single prime mover.

All models can be prepared for various applications:

- basic (B) for independent mounting
- with a overcenter industrial clutch (BD) (BDS)
- with housing and coupling connection for diesel engines.

Constructively the pump drives consist of:

- cast iron casing
- straight-tooth gears, case hardened
- hardened grinded (shaved in series AM 216 - AM 320)
- ball bearings
- shafts in case-hardening steel - case hardened - hardened
- viton seals on input shaft
- the kinematic diagram is identical for the various models: the primary gear, which transmits the drive to the secondary gears on whose axles the pumps are applied, is splined to the input shaft. The direction of rotation in output is the opposite of the rotation direction in input
- the transmission ratio is identical on all the outputs.

### TECHNICAL DATA

#### - Ratio

It represents the ratio between the input speed (speed of the prime mover) and the output speed (speed of the pumps).

Ratios lower than 1 indicate a pump drive unit performing as speed increaser, higher than 1 as speed reducer.

#### - Max input torque M1 (Nm)

It is the maximum torque which may be transmitted on input, corresponding to a theoretically unlimited gear life and to a bearing life (L10) of 10.000 hours at least.

For clutch coupled units, or when RBD coupling is mounted, the max input torque may be limited by the clutch or the RBD torque capacity.

#### - Each output max torque M2 (Nm)

It represents the maximum torque which may be transmitted on each output.

#### - Max speed n1 (RPM)

It is the maximum rotation speed at the input shaft. In case of clutch coupled unit, test that working speed is not more than the maximum permitted for the clutch.

#### - Moment of inertia J (Kgm<sup>2</sup>)

It is referred to the input shaft and it is calculated in accordance with ISO standards.

### SELECTION

The fundamental elements on which the choice of pump drive is based are:

- number and type of hydraulic pumps to be applied
- max torque absorbed by the pump (or by the group of pumps) on each output of the pump drive
- max power entering the pump drive
- Depending on the overall dimensions of the pumps, complete with pipes fittings, it is possible to establish the minimum distance between the pumps themselves.  
Comparing these values foreseen in the catalogue for the output shafts, it is possible to make a choice of type.
- Verify that the torque value of each output is kept below the max. value shown in the catalogue for the chosen pump drive.  
In cases of use in important industrial systems or in marine applications, it is necessary to bear in mind relevant safety factors.  
Also verify that the rotation speed of input shaft isn't more than the max. indicated in the catalogue.  
In the case of pump drives with clutch BD or BDS verify that the max. input torque is at least 20% below the max. transmittable from the clutch.
- Figure 1 shows the max input power advisable according to the pump drive model.

### COOLING

Oil working temperature must not exceed 105°C.

Depending on the input power and on duty, a cooling system may be necessary.

It is advisable to check the oil temperature during the first hours of work, making sure that the oil doesn't exceed 105°C.

All pump drives, except for AM 216 and AM 320, can be equipped on request with a cooling system consisting of an oil circulating pump mounted on the input shaft, pumps side, an oil/water cooler and relevant pipe fittings.

### DIESEL ENGINE CONNECTION

In cases of application to diesel engines, the pump drives can be supplied with housing and coupling suitable for engines with flywheel and flywheel housing dimensions according to SAE standards.

An example sketch of the dimensions to be checked is given in fig. 2.

The same dimensions are valid for connections with clutches.

The clutch pilot bearing (to assemble between the flywheel on the clutch shaft) is not included in the supply.

### INSTALLATION

The working position of the pump drive is usually the one shown in the catalogue.

If other positions are requested it is necessary to contact our Tech. Dept.

Special care must be taken over the fixing of the pump drive.

## APPLICATION EXAMPLES

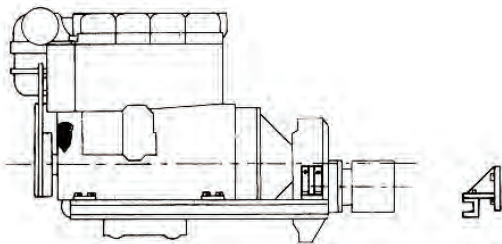

AM Pump Drive with pumps weight less than 100 kg.  
Normal support bracket.

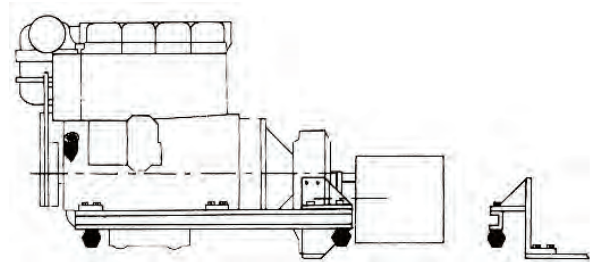

AM Pump Drive with total pumps weight more than 100 kg.  
The support bracket must be close to pump drive/pumps center of gravity.

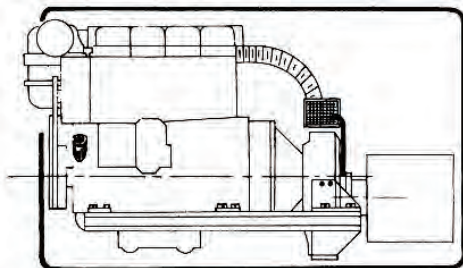

AM Pump Drive in closed surrounding without ventilation. A cooling system is needed.

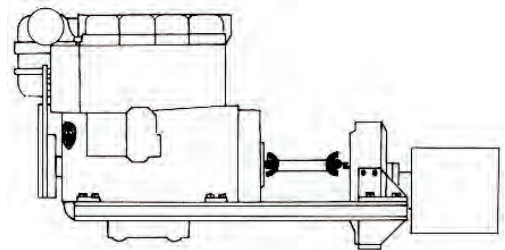

AM Pump Drive with cardan joint.  
The support bracket must be close to pump drive/pumps center of gravity.

## LUBRIFICATION

Use gear lube with EP additive and minimum viscosity index of 95.

The oil choice may be made taking account of the ambient temperature, as per tab. 3.

The pump drives are supplied without oil.

Before use fill to the maximum level mark on dipstick.

The oil quantity indicated in the catalogue is approximate.

Oil must be replaced after the first 50 working hours.

Subsequent oil changes should be made every 1.000 hours or every 12 months, whichever is the sooner.

Check regularly the oil level.

Oil working temperature must not exceed the 105°C.

## RECOMMENDED OIL TABLE

Ambient Temperature		Mineral Oil -15°C / +25°C	Mineral Oil -5°C / +40°C	Syntetic Oil -25°C / +80°C
Viscosity	ISO 3448	VG 100	VG 150	VG 150 - 220
	IV min.	95	95	165
MOBIL		MOBILGEAR 627	MOBILGEAR 629	MOBILGEAR SHC XMP 220
AGIP		BLASIA 100	BLASIA 150	BLASIA SX 220
BP		ENERGOL GR XP 100	GR XP 150	ENERSYNT HTX 220
CASTROL		ALPHA SP100	ALPHA SP150	ALPHASYNT 220
ELF		REDUCTELF SP100	REDUCTELF SP150	ORITIS 125 MS
ESSO		SPARTAN EP100	SPARTAN EP150	SPARTAN SYNT EP220
IP		MELLANA 100	MELLANA 150	TELESIA OIL 150
SHELL		OMALA OIL 100	OMALA OIL 150	OMALA OIL HD 200
TOTAL		CARTER EP100N	CARTER EP150	CARTER SH 220

## LOAD CLASSIFICATION BASED UPON AGMA LOAD CHARACTERISTICS

PRIME MOVER	DURATION OF SERVICE	DRIVEN MACHINE LOAD CLASSIFICATION		
		UNIFORM	MODERATE SHOCK	HEAVY SHOCK
Electric motor	Up to 3 hours per day	1.00	1.25	1.50
	3-10 hours per day	1.00	1.25	1.75
	Over 10 hours per day	1.25	1.50	2.00
Multi-cylinder internal combustion engine	Up to 3 hours per day	1.00	1.25	1.75
	3-10 hours per day	1.25	1.50	2.00
	Over 10 hours per day	1.50	1.75	2.25
Multi-cylinder internal combustion engine with high torque rise	Up to 3 hours per day	1.50	1.75	2.25
	3-10 hours per day	1.75	2.00	2.50
	Over 10 hours per day	2.00	2.25	2.75
Single cylinder internal combustion engine	Up to 3 hours per day	1.25	1.50	2.00
	3-10 hours per day	1.50	1.75	2.25
	Over 10 hours per day	1.75	2.00	2.50

TO CALCULATE APPLICATION TORQUE:

$$\frac{5252 \times \text{HP}}{\text{Engine speed (n/min.)}} = \text{Torque}$$

Torque x load factor = Application Torque

Use load factor from chart at left

All clutch engagements to be with prime mover below 1000 n/min.

High inertia loads may require use of larger clutch.

Contact our application engineering dept. for assistance.



## FLYWHEEL / FLYWHEEL HUSING DIMENSIONS - SAE J620 D / SAE J617 C

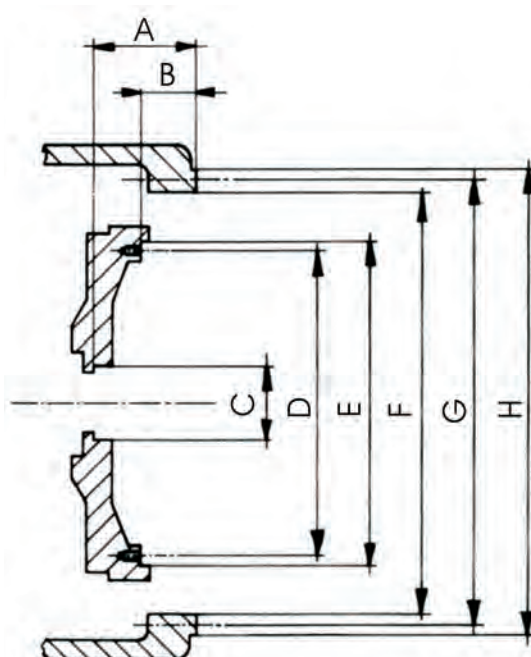

Clutch size	A	B	C	D	E
6 ½	71.4	30.2	52	200	215.9
8	100.1	62.0	62	244.48	263.52
10	100.1	53.8	72	295.27	314.32
11 ½	100.1	39,6	72	333,37	352.42
14	100.1	25,4	80	438.15	466.72

SAE n°.	F	G	H
1	511.17	530,22	552.4
2	447.67	466.72	489
3	409.57	428.62	450.8
4	361.95	381	4032
5	314.32	333.38	356

## INPUT CONFIGURATION

AM 110 - AM 216 - AM 220 - AM 320 - AM 330

### SAE Housing

SAE	Dimensions				
	A	B	C	G	H
1	552	530,2	511,2	12	50
2	489	466,7	447,7	11	50
3	451	428,6	409,6	11	50
4	403	381	361,9	11	50
5	356	333,4	314,3	11	35,5

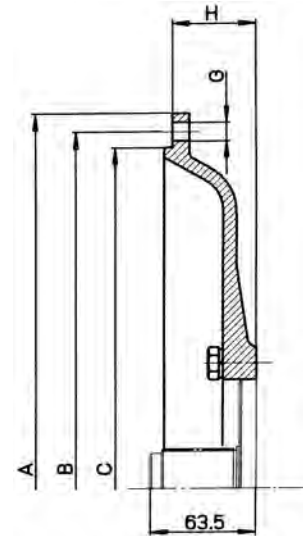

### RBD Couplings

FLYWHEEL	D	E	F	L	Max Torque Nm
8"	263,5	244,5	9	61,9	310
10"	314,3	295,3	IO	53,8	560
11-1/2"	352,4	333,4	IO	39,6	860
14"	466,7	438,2	41	25,4	1400

For torsional vibration calculation, contact our Tech. Dpt.

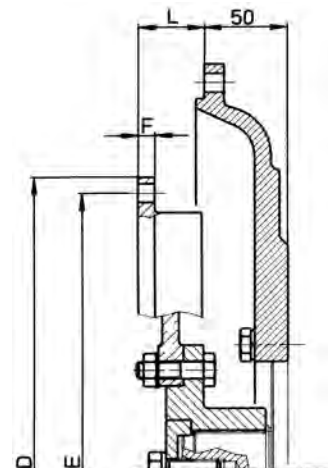

### Pump Pad Dimensions

Pump	AM 110	AM 216 - 220 - 320 - 330
	x - mm	x - mm
SAE A	18,5	10
SAE B	23,5	20
SAE C	22,5	20
SAE D	-	80
Gr 2	-	18
Gr 3	-	18
Gr 3,5	-	15

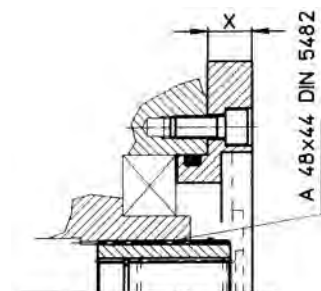



## INPUT CONFIGURATION AM 230 - AM 232 - AM 345 - AM 450

### SAE Housing

SAE	Dimensions				
	A	B	C	G	H
1	552	530,2	511,2	12	50
2	489	466,7	447,7	11	50
3	451	428,6	409,6	11	50
4	403	381	361,9	11	50

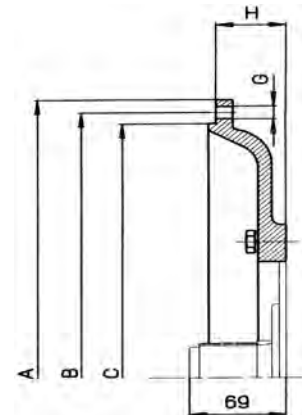

### RBD Couplings

FLYWHEEL	D	E	F	L	Max Torque Nm
10"	314,3	295,3	10	53,8	560
11-1/2"	352,4	333,4	10	39,6	860
14"	466,7	438,2	41	25,4	1400

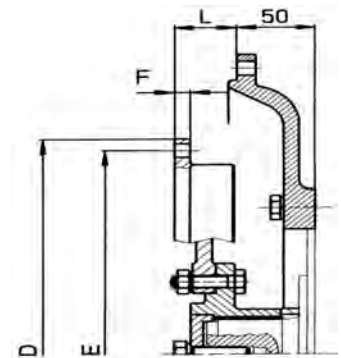

### TORSIONAL Couplings

For a proper selection contact our Tech. Dept.

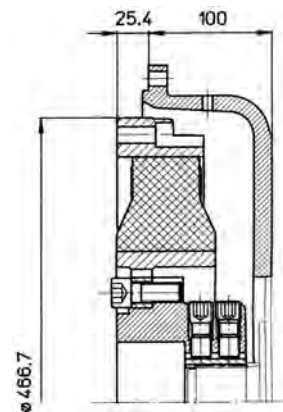

### Pump Pad Dimensions

Pump	x - mm
SAE A	19
SAE B	20
SAE C	28
SAE D	37
SAE E	37

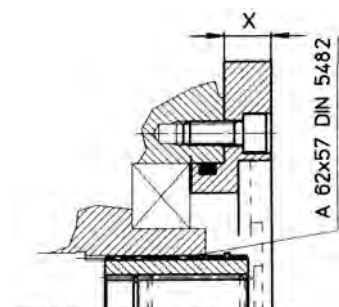

### INPUT CONFIGURATION AM 365 - AM 480

#### SAE Housing

SAE	A	B	C	G
1	552	530,2	511,2	12
0	711	679,5	647,7	12,5

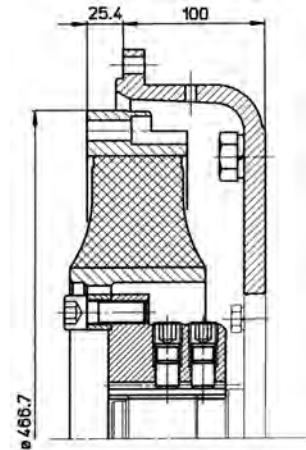
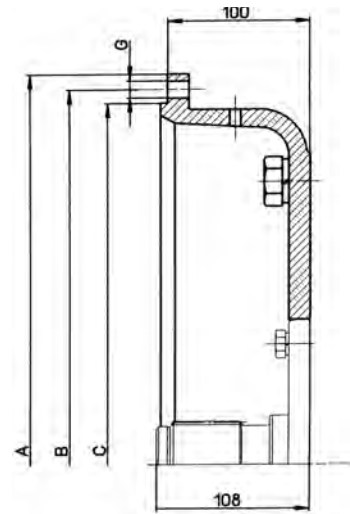

### TORSIONAL Couplings

For a proper selection contact our Tech.Dpt.

### Pump Pad Dimensions

Pump	AM 365 x - mm	AM 480 x - mm
SAE B	20	-
SAE C	28	28
SAE D	20	35
SAE E	30	35

### AM 365

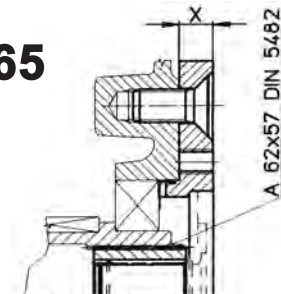

### AM 480

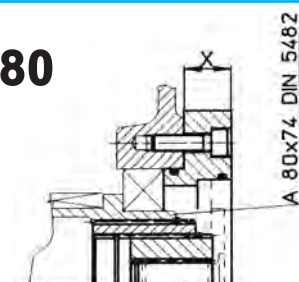

## AM 110 PUMP DRIVE

Max. Input Power 180 kW

### QUALITY IS STANDARD

- Cast iron housing
- Shaved gears
- Ball bearings
- Case-hardened shafts
- Viton seals on input shaft
- Output rotation opposite the direction of input rotation
- Gear ratios identical on all output
- Modular design



### AM 110 - TECHNICAL DATA

Ratio .....:1	Max. input torque Nm (lbf-ft)	Max. output torque per pump pad Nm (lbf-ft)	Max. input speed n /min.	Oil quantity lt (gal)
0,49	735 (542)	360 (265)	2400	2.3 (0.61)
0,58	705 (520)	410 (302)	2500	2.1 (0.55)
0,67	675 (499)	450 (332)	2650	1.9 (0.50)
0,77	635 (468)	490 (361)	2850	1.8 (0.46)
0,83	600 (442)	510 (376)	3000	1.8 (0.46)
1,00	540 (398)	540 (398)	3200	1.6 (0.42)
1,30	490 (361)	640 (555)	3600	1.3 (0.34)
1,50	450 (332)	675 (565)	3950	1,1 (0,29)

### AM 110 - MOMENT OF INERTIA DATA

RATIO .....:1	B kg.m <sup>2</sup> (lb-ff <sup>2</sup> )	BD 130 kg.m <sup>2</sup> (lb-ff <sup>2</sup> )	BD 145 kg.m <sup>2</sup> (lb-ff <sup>2</sup> )	BD 290 kg.m <sup>2</sup> (lb-ff <sup>2</sup> )	BDS 130 kg.m <sup>2</sup> (lb-ff <sup>2</sup> )	BDS 145 kg.m <sup>2</sup> (lb-ff <sup>2</sup> )	BDS 290 kg.m <sup>2</sup> (lb-ff <sup>2</sup> )
0.49	0.0825 (1.96)	0.2200 (5.22)	0.345 (8.18)	0.532 (12.63)	0.332 (7.89)	0.520 (12.34)	0.757 (17.97)
0.58	0.0717 (1.70)	0.2092 (4.96)	0.334 (7.93)	0.522 (12.38)	0.322 (7.63)	0.509 (12.08)	0.747 (17.72)
0.67	0.0642 (1.52)	0.2017 (4.79)	0.327 (7.75)	0.514 (12.20)	0.314 (7.45)	0.502 (11.90)	0.739 (17.54)
0.77	0.0544 (1.29)	0.1919 (4.55)	0.317 (7.52)	0.504 (11.97)	0.304 (7.22)	0.492 (11.67)	0.729 (17.31)
1.00	0.0405 (0.96)	0.1780 (4.22)	0.303 (7.19)	0.490 (11.64)	0.290 (6.89)	0.478 (11.34)	0.715 (16.98)
1.30	0.0325 (0.77)	0.1700 (4.03)	0.295 (7.00)	0.482 (11.45)	0.282 (6.70)	0.470 (11.15)	0.707 (16.79)
1.50	0.0290 (0.69)	0.1665 (3.95)	0.291 (6.92)	0.479 (11.36)	0.279 (6.62)	0.466 (11.07)	0.704 (16.70)

### AM 110 BD - BDS - CLUTCH CHARACTERISTICS

Clutch type	SAE size	Max Input Torque Nm	Max. Speed n/min	Power kW
BD 130	3-4	330	3100	70
BD 145	3-4	450	3100	80
BD 290	1-2-3	880	2900	150
BDS 130	-	330	3100	70
BDS 145	-	450	3100	80
BDS 290	-	880	2900	150

## AM 110 B

### Basic Model - Installation Drawing

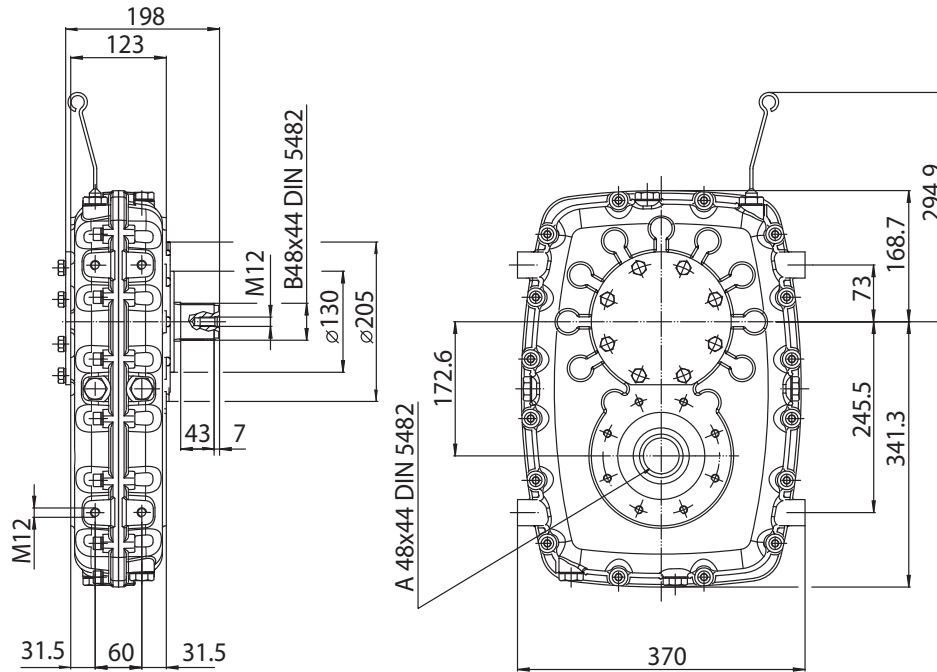

### AM 110 BD 130

With one plate 10" clutch

### AM 110 BD 145

With one plate 11" clutch

### AM 110 BD 290

With two plate 11" clutch

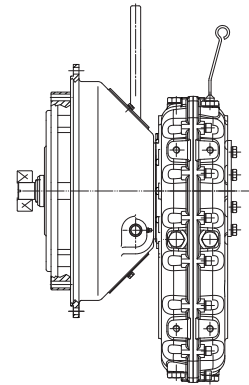

### AM 110 BDS 130

Independent mount with one plate 10" clutch

### AM 110 BDS 145

Independent mount with one plate 11" clutch

### AM 110 BDS 290

Independent mount with two plate 11" clutch

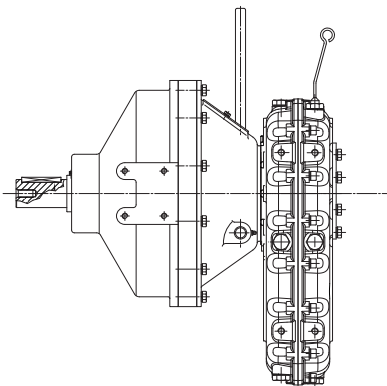

MODEL	WEIGHT kg (lbs)
AM 110 B	50 (110)
AM 110 BD 130	90 (198)
AM 110 BD 145	94 (207)
AM 110 BD 290	116 (256)
AM 110 BDS 130	121 (267)
AM 110 BDS 145	125 (276)
AM 110 BDS 290	143 (315)

## AM 110 BD

### Installation Drawing

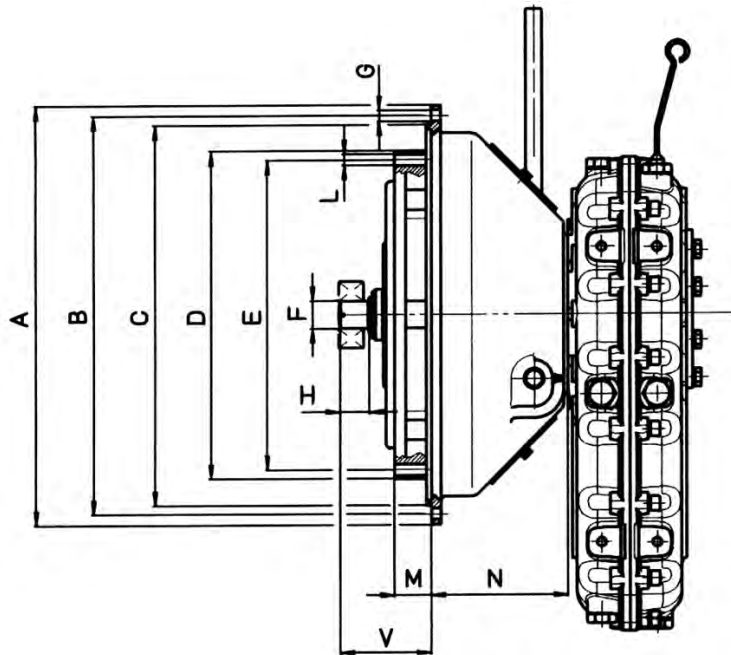

Clutch type	D	E	F	H	L	M	N	V
<b>BD 130</b>	314,32	295,27	30	37	n. 8 holes Ø 10.5	54	114	100
<b>BD 145</b>	352,42	333,37	30	37	n. 8 holes Ø 10.5	39,7	114	100
<b>BD 290</b>	352,42	333,37	30	37	n. 8 holes Ø 10.5	39,7	147	100

SAE	DIMENSIONS			
	A	B	C	G
1	552	530.22	511.17	n. 12 holes Ø 12
2	489	466.72	447.67	n. 12 holes Ø 11
3	451	428.62	409.57	n. 12 holes Ø 11
4	403.22	381	361.95	n. 12 holes Ø 11

## AM 110 BDS

### Installation Drawing

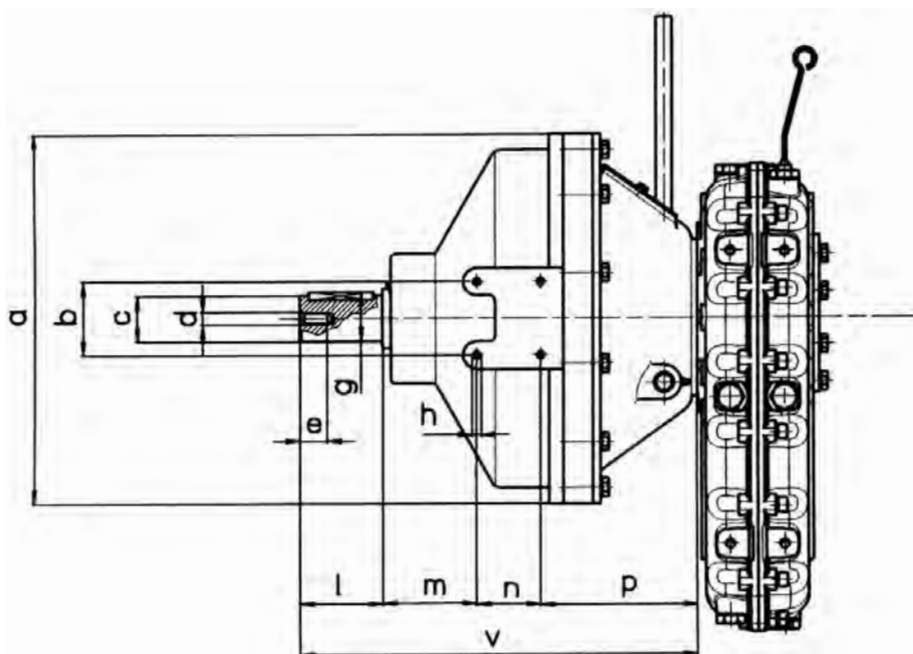

Clutch type	a	b	c	d	e	g	h	l	m	n	p	v
<b>BDS 130</b>	403	80	50	M 14	30	54	M 10	90	104	70	139	403
<b>BDS 145</b>	403	80	50	M 14	30	54	M 10	90	104	70	139	403
<b>BDS 290</b>	403	80	50	M 14	30	54	M 10	90	104	70	172	436



## AM 216 PUMP DRIVE

Max. Input Power 205 kW

### QUALITY IS STANDARD

- Cast iron housing
- Shaved gears
- Ball bearings
- Case-hardened shafts
- Viton seals on input shaft
- Output rotation opposite the direction of input rotation
- Gear ratios identical on all outputs
- Modular design



### AM 216 - TECHNICAL DATA

Ratio .....:1	Max. input torque Nm (lbf-ft)	Max. output torque per pump pad Nm (lbf-ft)	Max input speed n /min.	Max output speed n /min.	Oil quantity lt (gal)
0.50	800 (590)	200 (148)	2400	4800	1.9 (0.50)
0.68	735 (541)	250 (184)	2650	3897	2.0 (0.53)
0.79	700 (516)	275 (203)	2850	3608	2.0 (0.53)
0.89	670 (494)	300 (221)	3200	3595	1.7 (0.45)
1.00	630 (464)	315 (232)	3200	3200	1.7 (0.45)
1.13	560 (412)	320 (236)	3300	2920	1.7 (0.45)
1.27	550 (405)	475 (350)	3600	2835	1.5 (0.40)
1.47	500 (369)	488 (360)	3950	2687	1.3 (0.34)

### AM 216 - MOMENT OF INERTIA DATA

RATIO .....:1	B kg.m <sup>2</sup> (lb-ff <sup>2</sup> )	BD 130 kg.m <sup>2</sup> (lb-ff <sup>2</sup> )	BD 145 kg.m <sup>2</sup> (lb-ff <sup>2</sup> )	BDS 130 kg.m <sup>2</sup> (lb-ff <sup>2</sup> )	BDS 145 kg.m <sup>2</sup> (lb-ff <sup>2</sup> )
0.50					
0.68	0.0278 (0.66)	0.1653 (3.92)	0.2903 (6.89)	0.2778 (6.59)	0.4653 (11.04)
0.79	0.0248 (0.59)	0.1622 (3.85)	0.2873 (6.82)	0.2748 (6.52)	0.4623 (10.97)
1.00	0.0205 (0.49)	0.1580 (3.75)	0.2830 (6.72)	0.2705 (6.42)	0.4580 (10.87)
1.27	0.0167 (0.40)	0.1542 (3.66)	0.2792 (6.63)	0.2667 (6.33)	0.4542 (10.78)
1.47	0.0151 (0.36)	0.1526 (3.62)	0.2776 (6.59)	0.2651 (6.29)	0.4526 (10.74)

### AM 216 BD - BDS - CLUTCH CHARACTERISTICS

Clutch type	SAE size	Max input torque Nm	Max Speed n / min.	Power Kw
BD 130	3-4	330	3100	70
BD 145	3-4	450	3100	80
BDS 130	-	330	3100	70
BDS 145	-	450	3100	80

## AM 216 B

### Basic Model - Installation Drawing

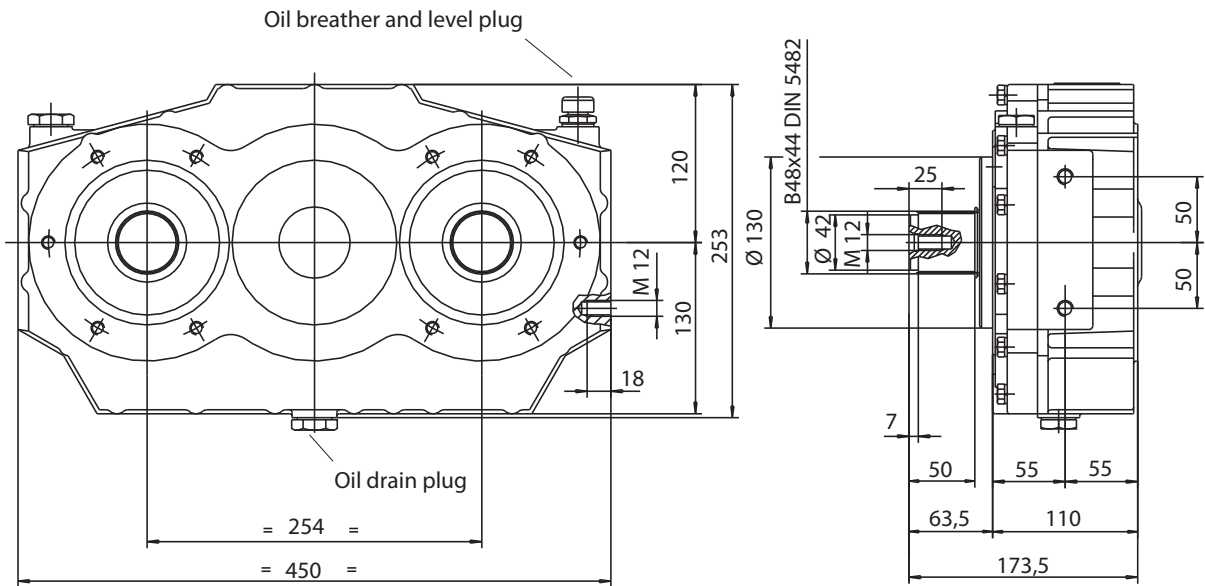

## AM 216 BD 130

With one plate 10" clutch

## AM 216 BD 145

With one plate 11" clutch

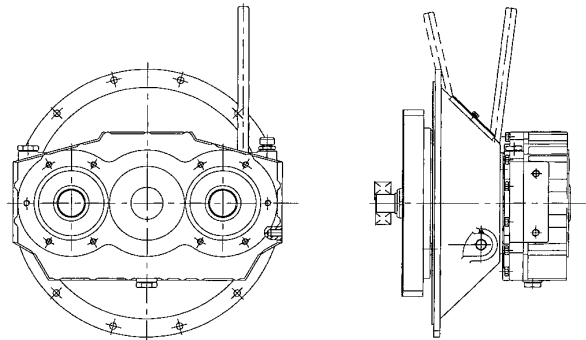

## AM 216 BDS 130

Independent mount with one plate 10" clutch

## AM 216 BDS 145

Independent mount with one plate 11" clutch

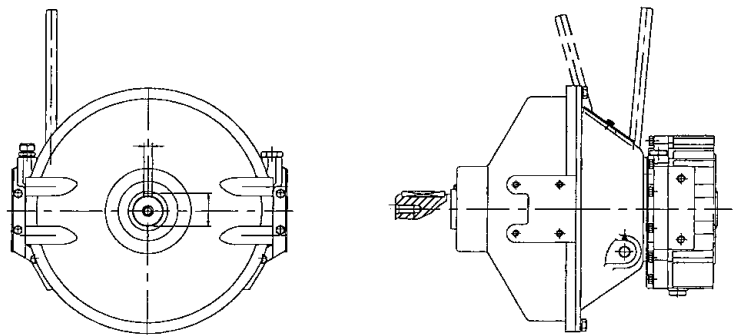

MODEL	WEIGHT kg (lb)
AM 216 B	36 (79)
AM 216 BD 130	76 (168)
AM 216 BD 145	80 (176)
AM 216 BDS 130	107 (236)
AM 216 BDS 145	111 (245)

## AM 216 BD

### Installation Drawing

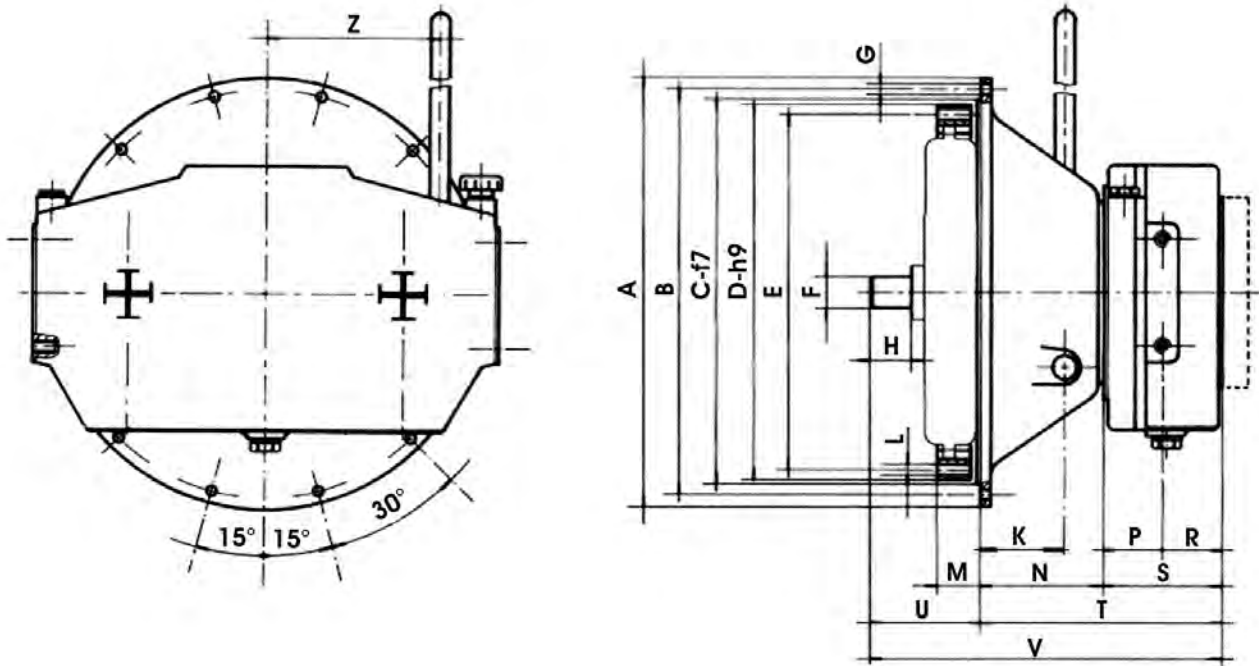

Clutch type	D	E	F	H	L	M	N	P	R	S	T	U	Z	K
<b>BD 130</b>	314.32	295.27	30	37	n. 8 holes Ø 10.5	54	114	55	110	225	1000	324	160	78
<b>BD 145</b>	352.42	333.37	30	37	n. 8 holes Ø 10.5	39.7	114	55	110	225	1000	324	160	78

SAE	DIMENSIONS			
	A	B	C	G
<b>3</b>	451	428.62	409.57	n. 12 holes Ø 11
<b>4</b>	403.22	381	361.95	n. 12 holes Ø 11

### AM 216 BDS

#### Installation Drawing

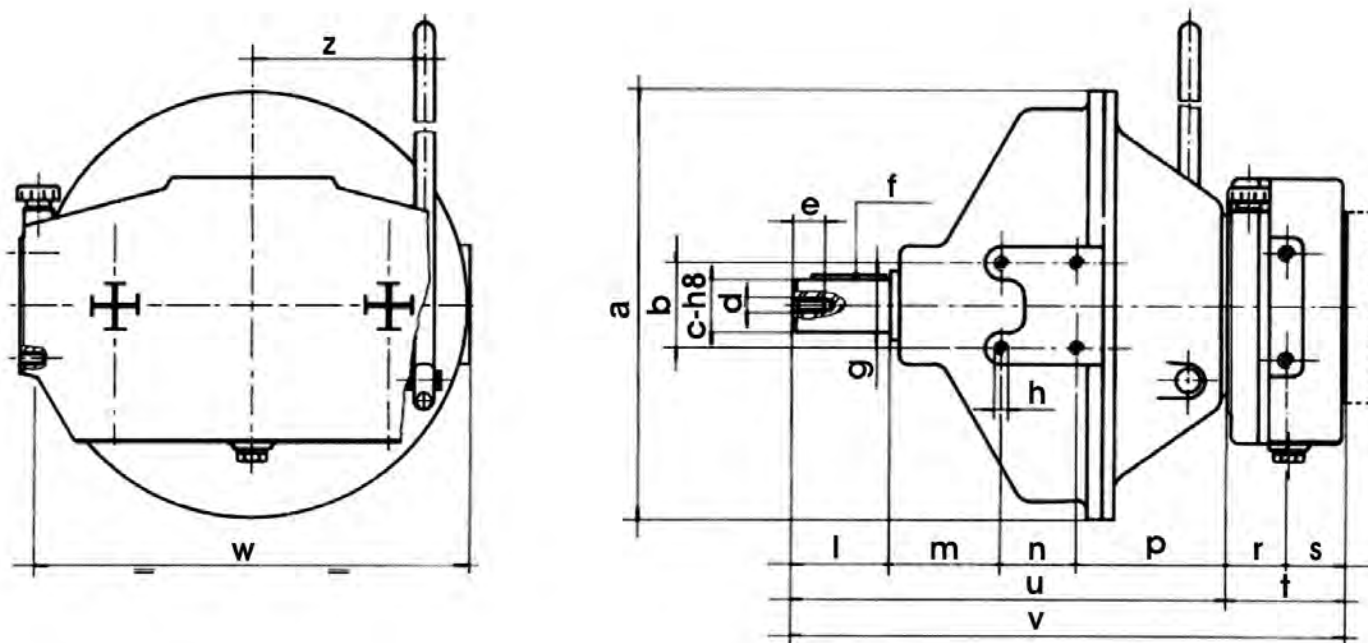

Clutch type	a	b	c	d	e	f	g	h	l	m	n	p	r	s	t	u	v	z	w
<b>BDS 130</b>	403	80	50	M14	30	14x9x70	54	M10	90	104	70	139	55	55	110	403	513	160	404
<b>BDS 145</b>	403	80	50	M14	30	14x9x70	54	M10	90	104	70	139	55	55	110	403	513	160	404

## AM 220 PUMP DRIVE

Max. Input Power 355 kW

### QUALITY IS STANDARD

- Cast iron housing
- Shaved gears
- Ball bearings
- Case-hardened shafts
- Viton seals on input shaft
- Output rotation opposite the direction of input rotation
- Gear ratios identical on all output
- Modular design



### AM 220 - TECHNICAL DATA

Ratio .....:1	Max. input torque Nm (lbf-ft)	Max. output torque per pump pad Nm (lbf-ft)	Max. input speed n /min.	Max. output speed n /min.	Oil quantity lt (gal)
0.49	1470 (1083)	360 (265)	2400	4898	2.5 (0.66)
0.58	1410 (1040)	410 (302)	2500	4310	2.0 (0.53)
0.67	1350 (994)	450 (332)	2650	3955	1.8 (0.48)
0.77	1270 (936)	490 (361)	2850	3701	1.8 (0.48)
0.83	1200 (885)	500 (368)	3000	3448	1,4 (0,37)
1.00	1080 (796)	540 (398)	3200	3200	1.4 (0.37)
1.30	980 (722)	640 (472)	3600	2769	1.4 (0.37)
1.50	900 (663)	675 (498)	3950	2633	1.2 (0.32)

### AM 220 - MOMENT OF INERTIA DATA

RATIO .....:1	B kg.m <sup>2</sup> (lb-ff <sup>2</sup> )	BD 130 kg.m <sup>2</sup> (lb-ff <sup>2</sup> )	BD 145 kg.m <sup>2</sup> (lb-ff <sup>2</sup> )	BD 290 kg.m <sup>2</sup> (lb-ff <sup>2</sup> )	BDS 130 kg.m <sup>2</sup> (lb-ff <sup>2</sup> )	BDS 145 kg.m <sup>2</sup> (lb-ff <sup>2</sup> )	BDS 290 kg.m <sup>2</sup> (lb-ff <sup>2</sup> )
0.49							
0.58							
0.67	0.0952 (2.26)	0.2327 (5.52)	0.358 (8.49)	0.545 (12.94)	0.345 (8.19)	0.533 (12.64)	0.770 (18.28)
0.77	0.0839 (1.99)	0.2214 (5.25)	0.346 (8.22)	0.540 (12.67)	0.334 (7.92)	0.521 (12.37)	0.759 (18.01)
1.00	0.0561 (1.33)	0.1936 (4.59)	0.319 (7.56)	0.506 (12.01)	0.306 (7.26)	0.494 (11.71)	0.731 (17.35)
1.30	0.0503 (1.19)	0.1878 (4.46)	0.313 (7.42)	0.500 (11.87)	0.300 (7.13)	0.488 (11.58)	0.725 (17.21)
1.50	0.0476 (1.13)	0.1851 (4.39)	0.310 (7.36)	0.498 (11.81)	0.298 (7.06)	0.485 (11.51)	0.723 (17.15)

### AM 220 BD - BDS - CLUTCH CHARACTERISTICS

Clutch type	SAE size	Max input torque Nm	Max Speed n / min.	Power Kw
BD 130	3-4	330	3100	70
BD 145	3-4	450	3100	80
BD 290	1-2-3	880	2900	150
BDS 130	-	330	3100	70
BDS 145	-	450	3100	80
BDS 290	-	880	2900	150

## AM 220 B

### Basic Model - Installation Drawing

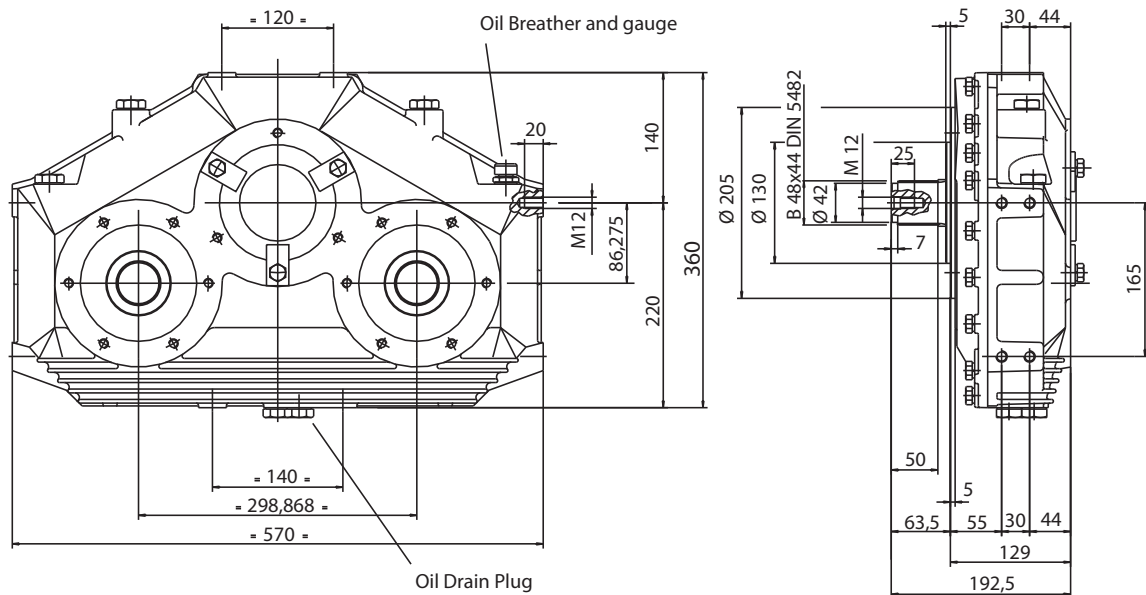

### AM 220 BD 130

With one plate 10" clutch

### AM 220 BD 145

With one plate 11" clutch

### AM 220 BD 290

With two plate 11" clutch

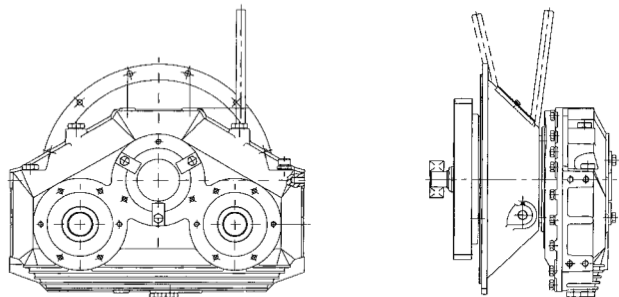

### AM 220 BDS 130

Independent mount with one plate 10" clutch

### AM 220 BDS 145

Independent mount with one plate 11" clutch

### AM 220 BDS 290

Independent mount with two plate 11" clutch

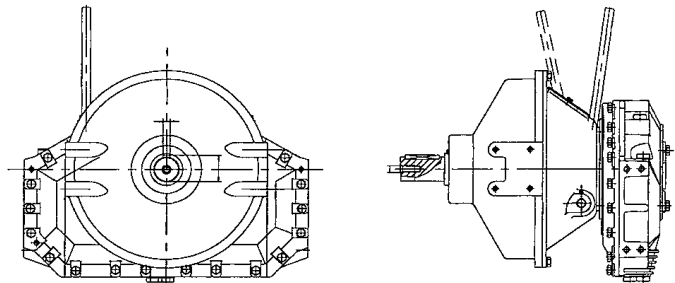

MODEL	WEIGHT kg (lbs)
AM 220 B	70 (154)
AM 220 BD 130	110 (243)
AM 220 BD 145	114 (251)
AM 220 BD 290	136 (300)
AM 220 BDS 130	141 (311)
AM 220 BDS 145	145 (320)
AM 220 BDS 290	163 (359)



## AM 220 BD

### Installation Drawing

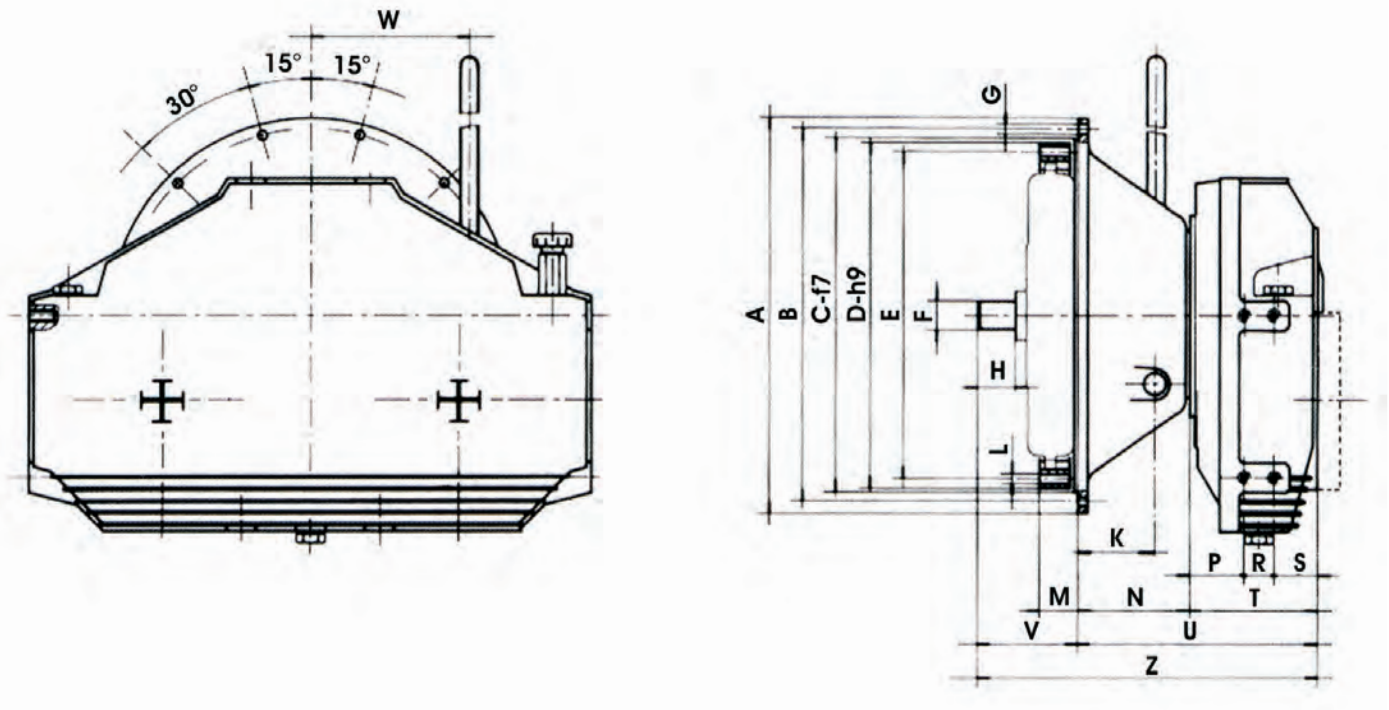

Clutch type	D	E	F	H	L	M	N	P	R	S	T	U	V	Z	K	W
<b>BD 130</b>	314.32	295.27	30	37	n. 8 holes Ø 10.5	54	114	55.5	30	43.5	129	243	100	343	78	160
<b>BD 145</b>	352.42	333.37	30	37	n. 8 holes Ø 10.5	39.7	114	55.5	30	43.5	129	243	100	343	78	160
<b>BD 145</b>	352.42	333.37	30	37	n. 8 holes Ø 10.5	39.7	147	55.5	30	43.5	129	243	100	343	111	205

SAE	DIMENSIONS			
	A	B	C	G
1	552	530.22	511.17	n. 12 holes Ø 12
2	489	466.72	447.67	n. 12 holes Ø 11
3	451	428.62	409.57	n. 12 holes Ø 11
4	403.22	381	361.95	n. 12 holes Ø 11

### AM 220 BDS

#### Installation Drawing

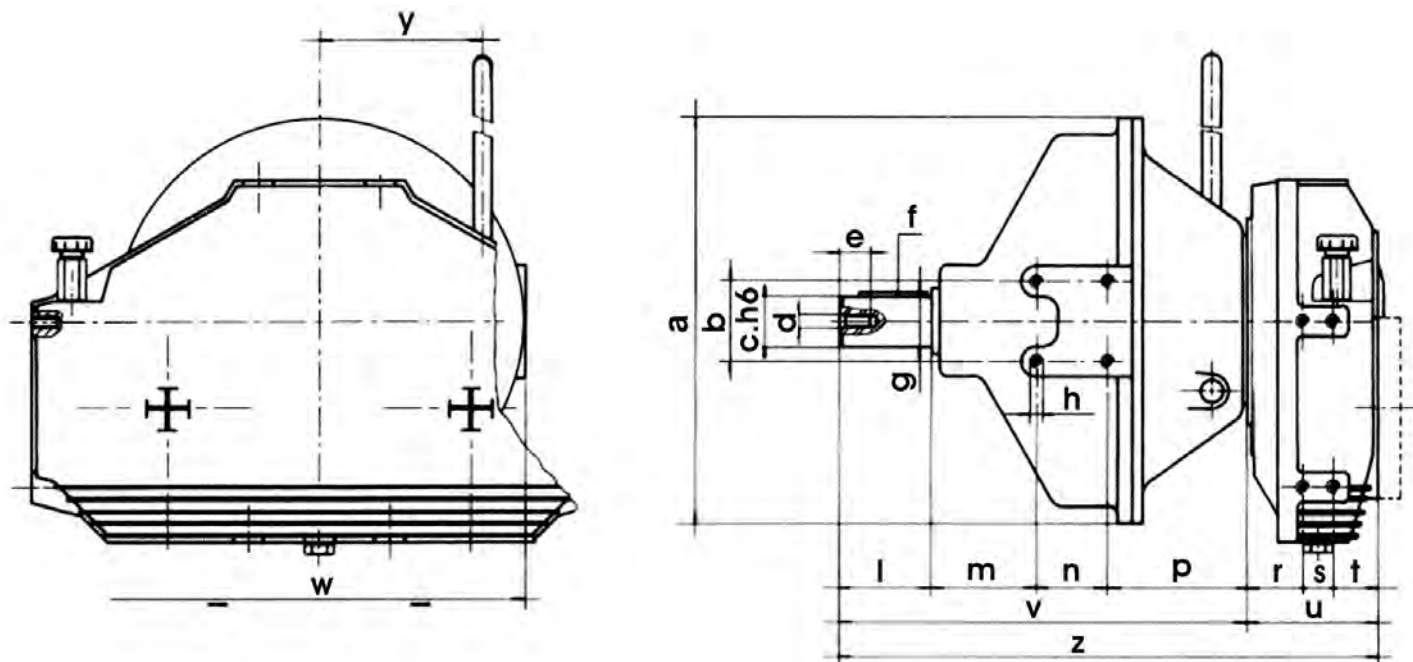

Clutch type	a	b	c	d	e	f	g	h	l	m	n	p	r	s	t	u	v	z	w	y
<b>BDS 130</b>	403	80	50	M14	30	14x9x70	54	M10	90	104	70	139	55.5	30	43.5	403	513	160	404	160
<b>BDS 145</b>	403	80	50	M14	30	14x9x70	54	M10	90	104	70	139	55.5	30	43.5	403	513	160	404	160
<b>BDS 290</b>	403	80	50	M14	30	14x9x70	54	M10	90	104	70	139	55.5	30	43.5	403	513	160	404	160

## AM 230 PUMP DRIVE

Max. Input Power 430 kW

### QUALITY IS STANDARD

- Cast iron housing
- Case-hardened and ground spur gears
- Ball bearings
- Case-hardened shafts
- Viton seals on input shaft
- Output rotation opposite the direction of input rotation
- Gear ratios identical on all output
- Modular design



### AM 230 - TECHNICAL DATA

Ratio .....:1	Max. input torque Nm (lbf-ft)	Max. output torque per pump pad Nm (lbf-ft)	Max. input speed n /min.	Max. output speed n /min.	Oil quantity lt (gal)
0.51	2080 (1532)	530 (390)	1950	3900	5.5 (1.45)
0.58	2010 (1481)	580 (427)	2050	3534	5.0 (1.32)
0.67	1910 (1408)	640 (472)	2200	3284	4.5 (1.19)
0.76	1840 (1356)	700 (516)	2300	3026	4.0 (1.06)
0.89	1680 (1238)	750 (553)	2400	2696	3.7 (0.98)
1.00	1620 (1193)	810 (597)	2600	2600	3.7 (0.98)
1.31	1390 (1024)	910 (671)	3000	2290	3.2 (0.85)
1.48	1270 (936)	940 (693)	3200	2162	3.0 (0.79)

### AM 230 - MOMENT OF INERTIA DATA

RATIO .....:1	B kg.m <sup>2</sup> (lb-ff <sup>2</sup> )	BD 290 kg.m <sup>2</sup> (lb-ff <sup>2</sup> )	BD 2200 kg.m <sup>2</sup> (lb-ff <sup>2</sup> )	BD 3300 kg.m <sup>2</sup> (lb-ff <sup>2</sup> )	BDS 290 kg.m <sup>2</sup> (lb-ff <sup>2</sup> )	BDS 2200 kg.m <sup>2</sup> (lb-ff <sup>2</sup> )
0.51						
0.58						
0.67	0.2099 (4.98)	0.660 (15.66)	2.035 (48.29)	2.760 (65.49)	0.885 (21.00)	3.210 (76.17)
0.76	0.1840 (4.37)	0.634 (15.04)	2.009 (47.67)	2.734 (64.88)	0.859 (20.38)	3.184 (75.56)
1.00	0.1191 (2.83)	0.569 (13.50)	1.944 (46.13)	2.669 (63.34)	0.794 (18.84)	3.119 (74.02)
1.31	0.1082 (2.57)	0.558 (13.25)	1.933 (45.88)	2.658 (63.08)	0.783 (18.59)	3.108 (73.76)
1.48	0.1036 (2.46)	0.554 (13.14)	1.929 (45.77)	2.654 (62.97)	0.779 (18.48)	3.104 (73.65)

### AM 230 BD - BDS - CLUTCH CHARACTERISTICS

Clutch type	SAE size	Max input torque Nm	Max Speed n / min.	Power Kw
BD 290	1-2-3	880	2900	150
BD 2200	1	1960	2400	230
BD 3300	1	2940	2400	320
BDS 290		880	2900	150
BDS 2200		1960	2400	230
BDS 3300		2940	2400	320

## AM 230 B

### Basic Model - Installation Drawing

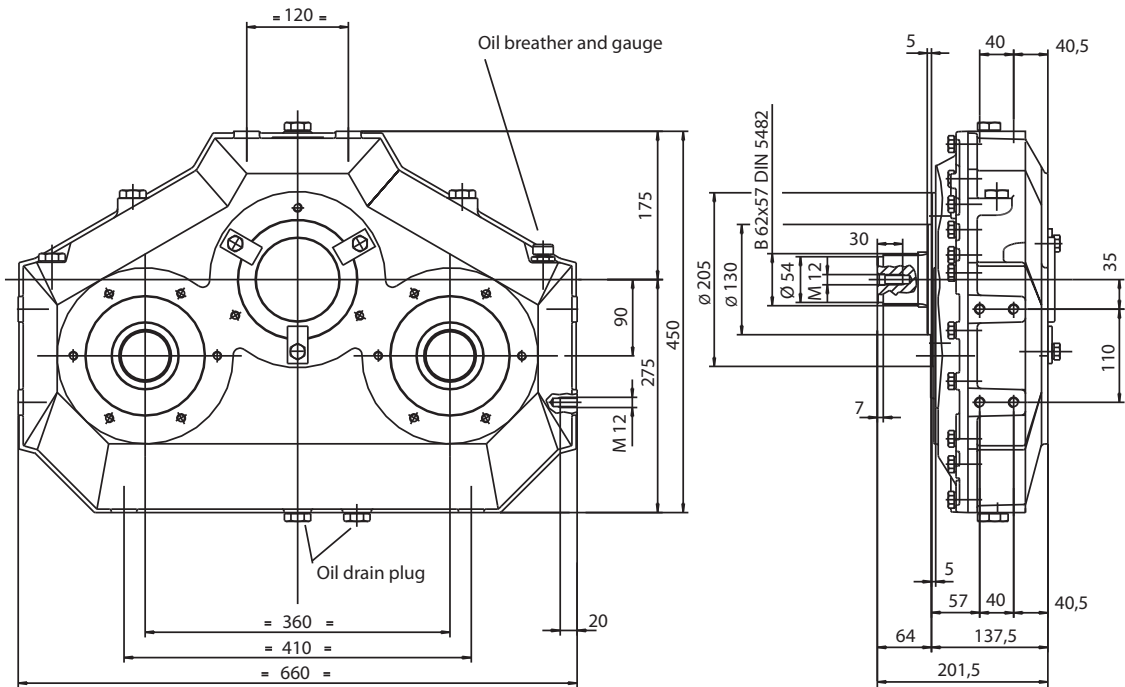

## AM 230 BD 290

With two plate 11" clutch

## AM 230 BD 2200

With two plate 14" clutch

## AM 230 BD 3300

With three plate 14" clutch

## AM 230 BDS 290

Independent mount with two plate 11" clutch

## AM 230 BDS 2200

Independent mount with two plate 14" clutch

## AM 230 BDS 3300

Independent mount with three plate 14" clutch

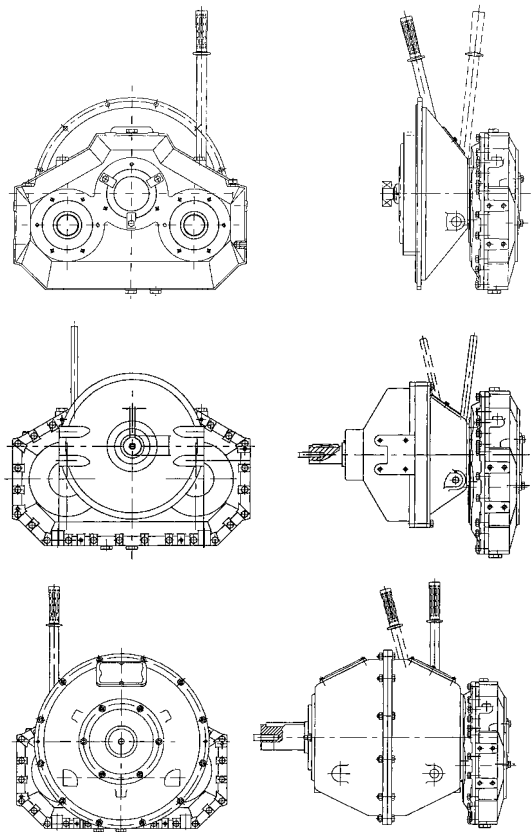

MODEL	WEIGHT kg (lbs)
AM 230 B	94 (207)
AM 230 BD 290	160 (352)
AM 230 BD 2200	227 (499)
AM 230 BD 3300	270 (594)
AM 230 BDS 290	187 (411)
AM 230 BDS 2200	337 (741)
AM 230 BDS 3300	361 (793)

## AM 230 BD

### Installation Drawing

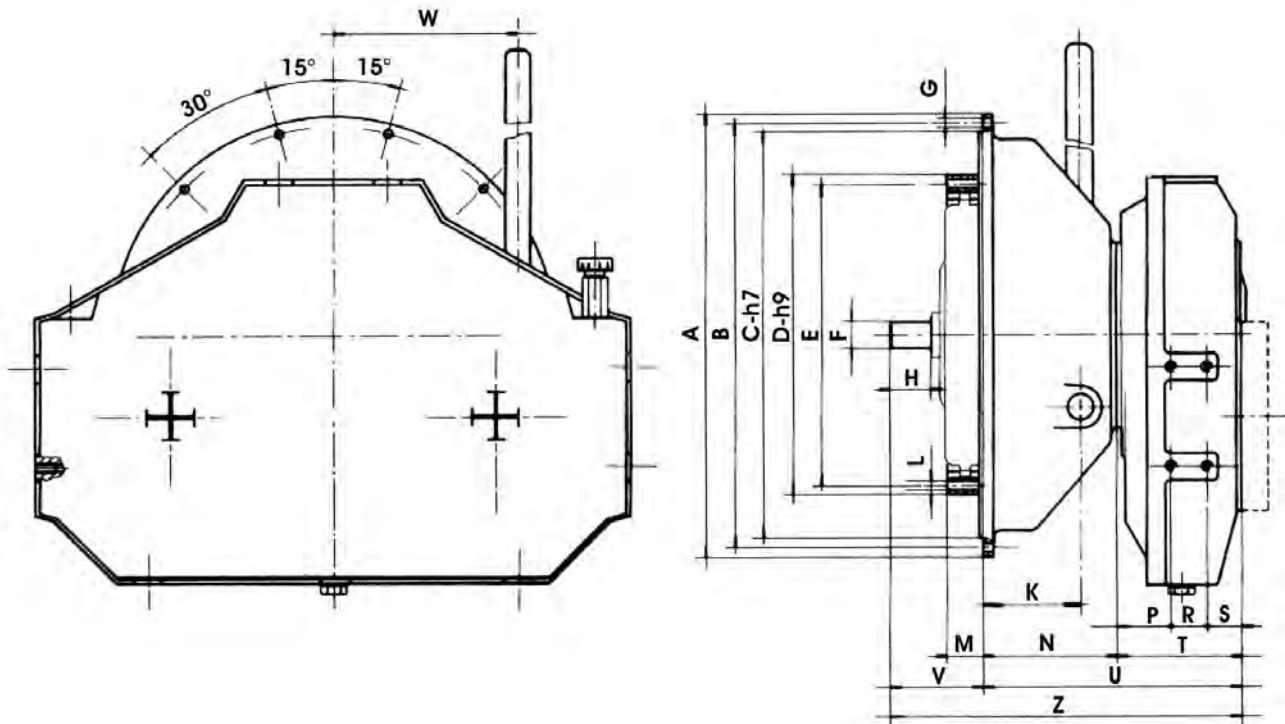

Clutch type	D	E	F	H	L	M	N	P	R	S	T	U	V	Z	K	W
<b>BD 290</b>	352,42	333,37	30	37	n. 8 holes Ø 10.5	39,7	147	57	40	40	137	284	100	384	78	160
<b>BD 2200</b>	466,72	438,15	35	37	n. 8 holes Ø 10.5	25.4	236	52	40	40	132	368	100	468	179	215
<b>BD 3300</b>	466,72	438,15	35	37	n. 8 holes Ø 10.5	25.4	264	52	40	40	132	396	100	496	207	215

SAE	DIMENSIONS			
	A	B	C	G
<b>1</b>	552	530,22	511,17	n. 12 holes Ø 12
<b>2</b>	469	466.72	447,67	n. 12 holes Ø 11
<b>3</b>	451	428.62	409,57	n. 12 holes Ø 11

### AM 230 BDS

#### Installation Drawing

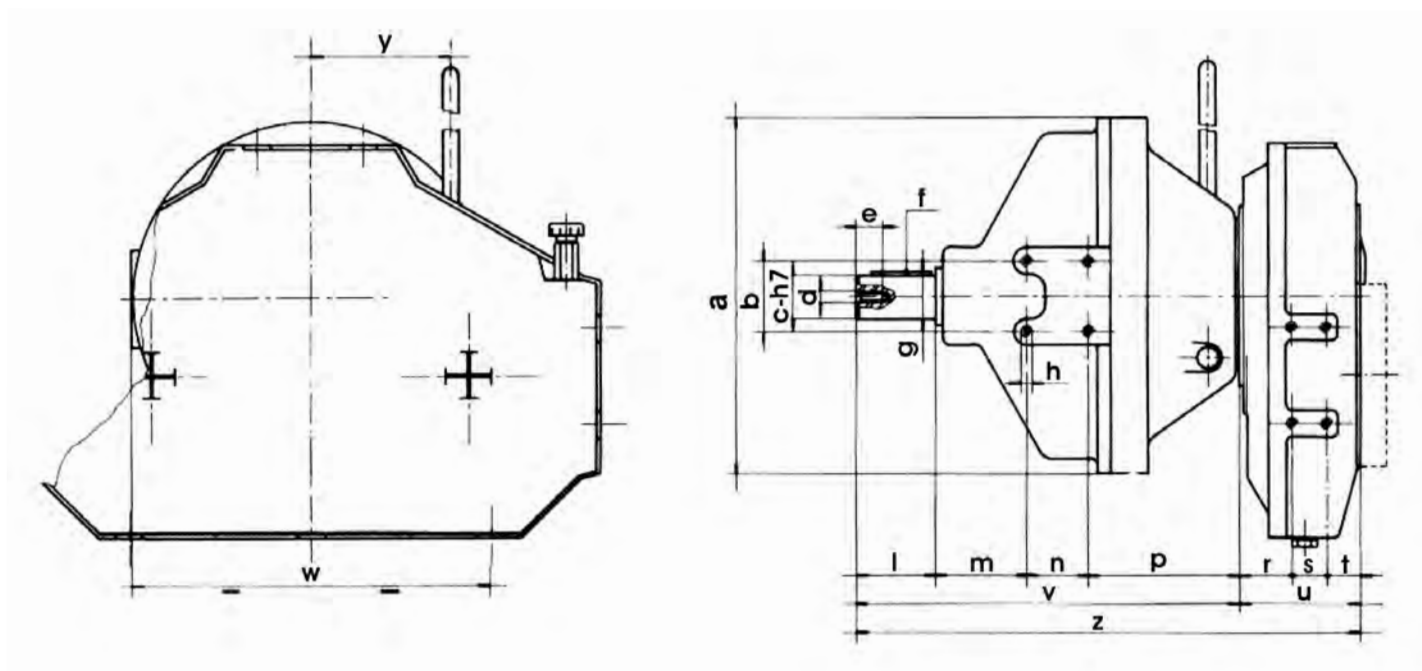

Clutch type	a	b	c	d	e	f	g	h	i	m	n	p	r	s	t
<b>BDS 290</b>	403	80	50	M 14	30	14x9x70	54	M 10	90	104	70	172	57	40	40
<b>BDS 2200</b>	552		80	M 20	45	24x14x120	87		135				52	40	40
<b>BDS 3300</b>	552	-	80	M 20	45	24x14x120	87		35	-	-	-	52	40	40



## AM 232 PUMP DRIVE

Max. Input Power 565 kW

### QUALITY IS STANDARD

- Cast iron housing
- Case-hardened and ground spur gears
- Ball bearings
- Case-hardened shafts
- Viton seals on input shaft
- Output rotation opposite the direction of input rotation
- Gear ratios identical on all output
- Modular design



### AM 232 - TECHNICAL DATA

Ratio .....:1	Max. input torque Nm (lbf-ft)	Max. output torque per pump pad Nm (lbf-ft)	Max. input speed n /min.	Max. output speed n /min.	Oil quantity lt (gal)
0,49	3250 (2397)	800 (589)	1750	3571	5.0 (1.32)
0,67	2800 (2063)	950 (700)	2000	2889	5.0 (1.32)
0,77	2700 (1989)	1050 (773)	2100	2727	5,0 (1.32)
0,83	2650 (1953)	1100 (810)	2100	2727	4.5 (1.19)
1,00	2300 (1695)	1150 (847)	2400	2400	4,5 (1,19)

### AM 232 - MOMENT OF INERTIA DATA

RATIO .....:1	B kg.m <sup>2</sup> (lb-ff <sup>2</sup> )	BD 290 kg.m <sup>2</sup> (lb-ff <sup>2</sup> )	BD 2200 kg.m <sup>2</sup> (lb-ff <sup>2</sup> )	BD 3300 kg.m <sup>2</sup> (lb-ff <sup>2</sup> )	BDS 290 kg.m <sup>2</sup> (lb-ff <sup>2</sup> )	BDS 2200 kg.m <sup>2</sup> (lb-ff <sup>2</sup> )
0.49	0.3184 (7.56)	0.768 (18.23)	2.143 (50.86)	2.868 (68.07)	0.993 (23.57)	3.318 (78.75)
0.77	0.2292 (5.44)	0.679 (16.12)	2.054 (48.75)	2.794 (66.29)	0.904 (21.46)	3.229 (76.63)
1.00	0.2026 (4.81)	0.653 (15.49)	2.028 (48.12)	2.753 (65.32)	0.878 (20.83)	3.203 (76.00)

### AM 232 BD - BDS - CLUTCH CHARACTERISTICS

Clutch type	SAE size	Max input torque Nm	Max Speed n / min.	Power Kw
BD 290	1-2-3	880	2900	150
BD 2200	1	1960	2400	230
BD 3300	1	2940	2400	320
BDS 290		880	2900	150
BDS 2200		1960	2400	230
BDS 3300		2940	2400	320

## AM 232 B

### Basic Model - Installation Drawing

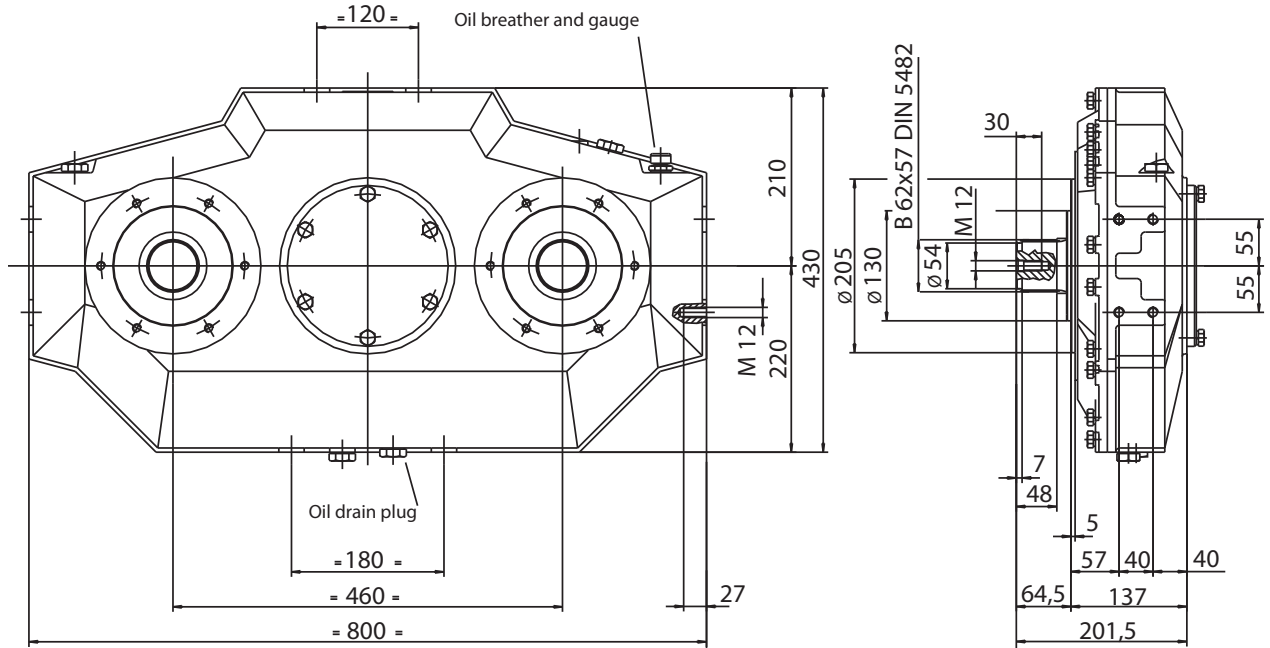

## AM 232 BD 290

With two plate 11" clutch

## AM 232 BD 2200

With two plate 14" clutch

## AM 232 BD 3300

With three plate 14" clutch

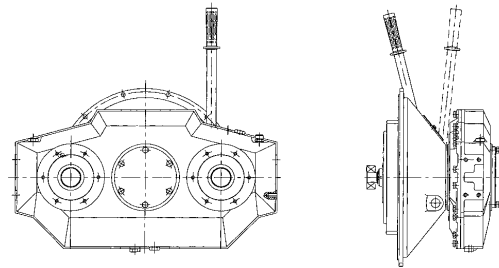

## AM 232 BDS 290

Independent mount with two plate 11" clutch

## AM 232 BDS 2200

Independent mount with two plate 14" clutch

## AM 232 BDS 3300

Independent mount with three plate 14" clutch

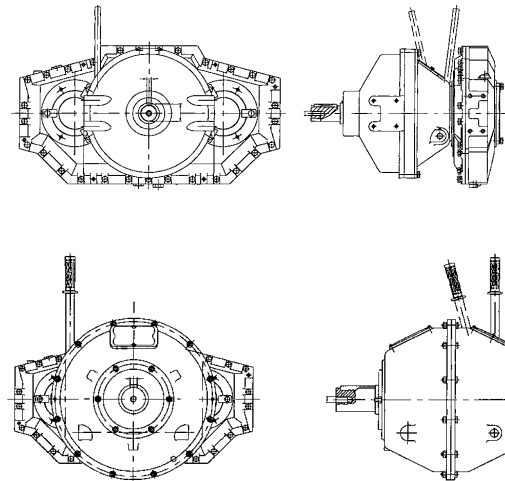

MODEL	WEIGHT kg (lbs)
AM 232 B	126 (278)
AM 232 BD 290	192 (423)
AM 232 BD 2200	259 (571)
AM 232 BD 3300	302 (666)
AM 232 BDS 290	219 (483)
AM 232 BDS 2200	369 (814)
AM 232 BDS 3300	393 (864)

## AM 232 BD

### Installation Drawing

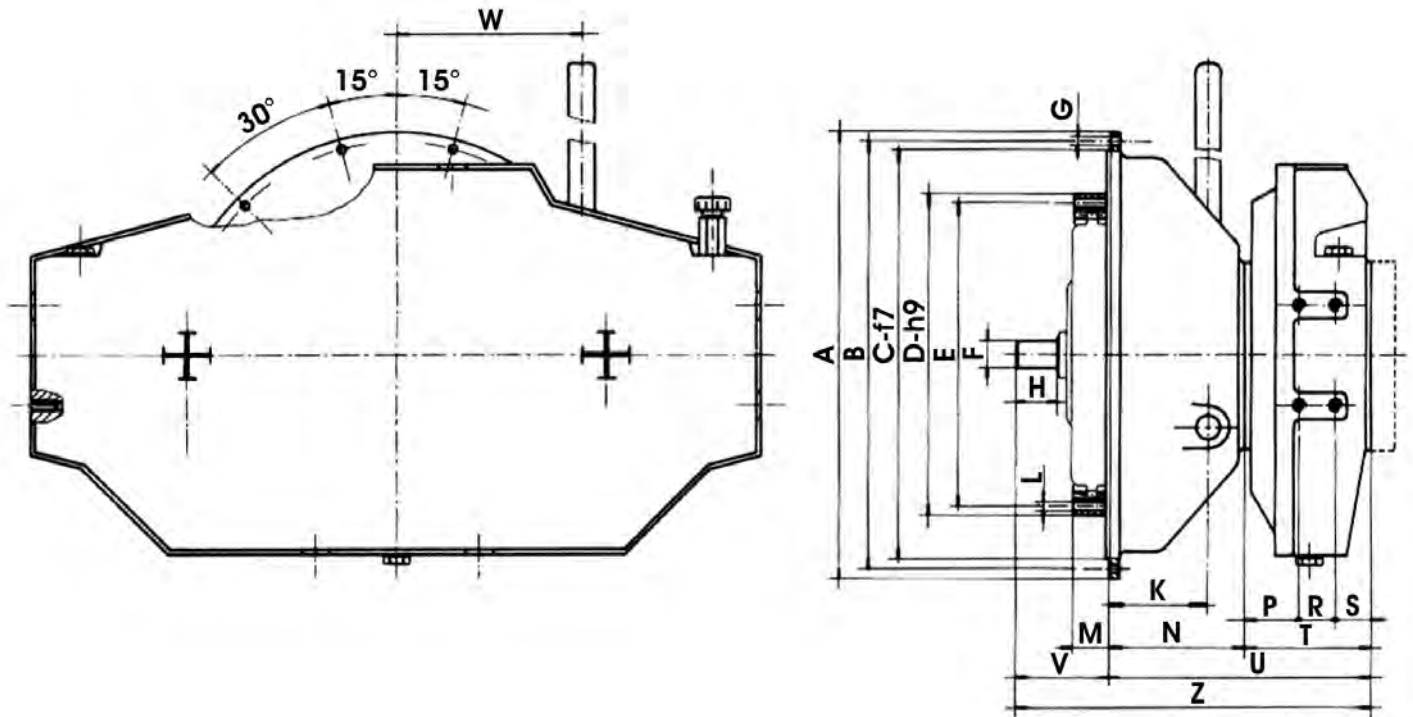

Clutch type	D	E	F	H	L	M	N	P	R	S	T	U	V	Z	K	W
<b>BD 290</b>	352.42	333,37	30	37	n. 8 holes Ø 10.5	39,7	147	57	40	40	137	284	100	384	78	160
<b>BD 2200</b>	166.72	438.15	35	37	n. 8 holes Ø 10.5	25.4	236	52	40	40	132	368	100	468	179	215
<b>BD 3300</b>	466,72	438.15	35	37	n. 8 holes Ø 10.5	25.4	264	52	40	40	132	396	100	496	207	215

SAE	DIMENSIONS			
	A	B	C	G
<b>1</b>	552	530.22	511,17	n. 12 holes Ø 12
<b>2</b>	489	466,72	447,67	n. 12 holes Ø 11
<b>3</b>	451	428,62	409,57	n. 12 holes Ø 11

### AM 232 BDS

#### Installation Drawing

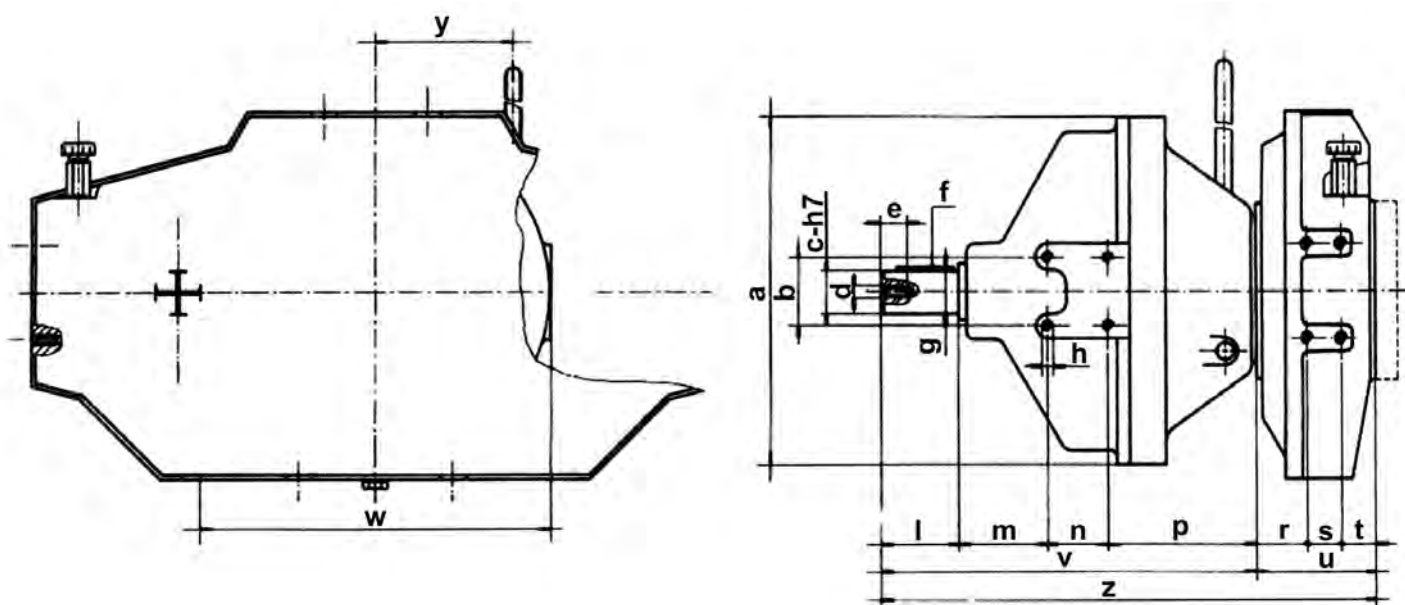

Clutch type	a	b	c	d	e	f	g	h	i	m	n	p	r	s	t	u	v	l	w	y
<b>BDS 290</b>	403	80	50	M 14	30	14x9x70	54	M10	90	104	70	172	57	40	40	137	436	573	404	160
<b>BDS 2200</b>	552		80	M 20	45	24x14x120	87	-	135	-	-		52	40	40	132	634	766		215
<b>BDS 3300</b>	552		80	M 20	45	24x14x120	87		135				52	40	40	132	662	794		215

## AM 320 PUMP DRIVE

Max. Input Power 205 kW

### QUALITY IS STANDARD

- Cast iron housing
- Shaved gears
- Ball bearings
- Case-hardened shafts
- Viton seals on input shaft
- Output rotation opposite the direction of input rotation
- Gear ratios identical on all output
- Modular design



### AM 320 - TECHNICAL DATA

Ratio .....:1	Max. input torque Nm (lbf-ft)	Max. output torque per pump pad Nm (lbf-ft)	Max. input speed n /min.	Max. output speed n /min.	Oil quantity lt (gal)
0,68	735 (542)	250 (184)	2650	3897	3.1 (0,82)
0,79	700 (516)	275 (203)	2850	3607	2,4 (064)
0,89	670 (494)	300 (222)	3200	3595	1.7 (0,45)
1,00	630 (464)	315 (232)	3200	3200	2,2 (0,59)
1,13	560 (413)	320 (236)	3300	2920	1.7 (0,45)
1,27	550 (405)	350 (258)	3600	2834	2,0 (0,53)
1,47	500 (368)	365 (269)	3950	2687	1,8 (0,48)

### AM 320 - MOMENT OF INERTIA DATA

RATIO .....:1	B kg.m <sup>2</sup> (lb-ff <sup>2</sup> )	BD 130 kg.m <sup>2</sup> (lb-ff <sup>2</sup> )	BD 145 kg.m <sup>2</sup> (lb-ff <sup>2</sup> )	BDS 130 kg.m <sup>2</sup> (lb-ff <sup>2</sup> )	BDS 145 kg.m <sup>2</sup> (lb-ff <sup>2</sup> )
0.68	0,0344 (0,82)	0,1719 (4,08)	0,2969 (7,05)	0,2844 (6,75)	0,4719 (11,20)
0,79	0,0312 (0,74)	0,1688 (4,01)	0,2937 (6,97)	0,2812 (6,67)	0,4688 (11,12)
1,00	0,0271 (0,64)	0,1646 (3,91)	0,2896 (6,87)	0,2771 (6,58)	0,4646 (11,03)
1,27	0,0226 (0,54)	0,1601 (3,80)	0,2851 (6,77)	0,2726 (6,47)	0,4601 (10,92)
1,47	0,0206 (0,49)	0,1581 (3,75)	0,2832 (6,72)	0,2707 (6,42)	0,4582 (10,87)

### AM 320 BD - BDS - CLUTCH CHARACTERISTICS

Clutch type	SAE size	Max input torque Nm	Max Speed n / min.	Power Kw
BD 130	3-4	330	3100	70
BD 145	3-4	450	3100	80
BDS 130	-	330	3100	70
BDS 145	-	450	3100	80

## AM 320 B

### Basic Model - Installation Drawing

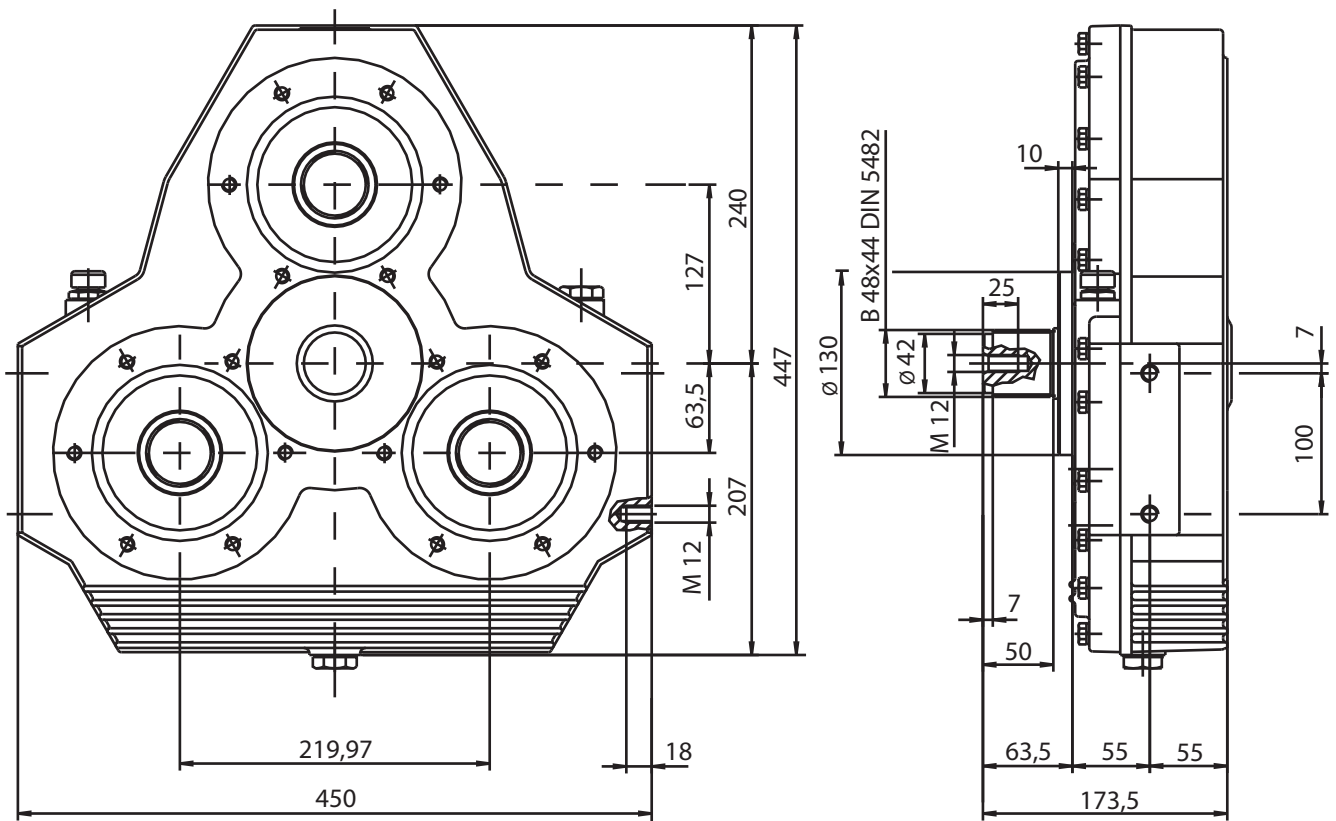

## AM 320 BD 130

With one plate 10" clutch

## AM 320 BD 145

With one plate 11" clutch

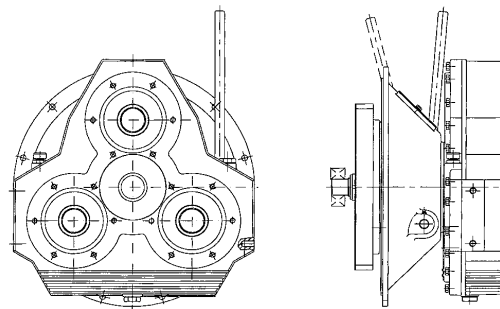

## AM 320 BDS 130

Independent mount with one plate 10" clutch

## AM 320 BDS 145

Independent mount with one plate 11" clutch

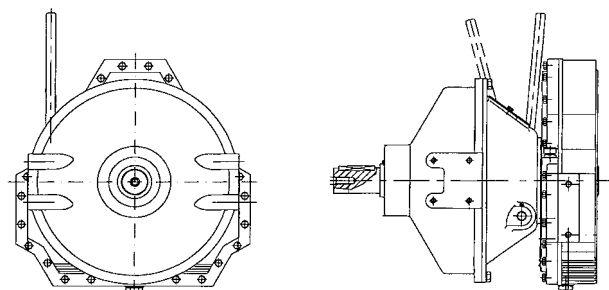

MODEL	WEIGHT kg (lbs)
AM 320 B	42 (93)
AM 320 BD 130	82 (181)
AM 320 BD 145	86 (190)
AM 320 BDS 130	113 (249)
AM 320 BDS 145	117 (258)



## AM 320 BD

### Installation Drawing

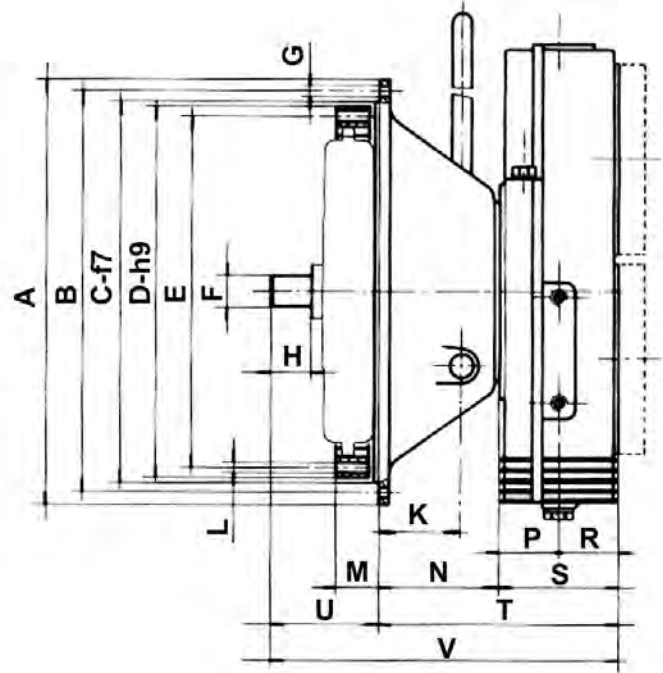
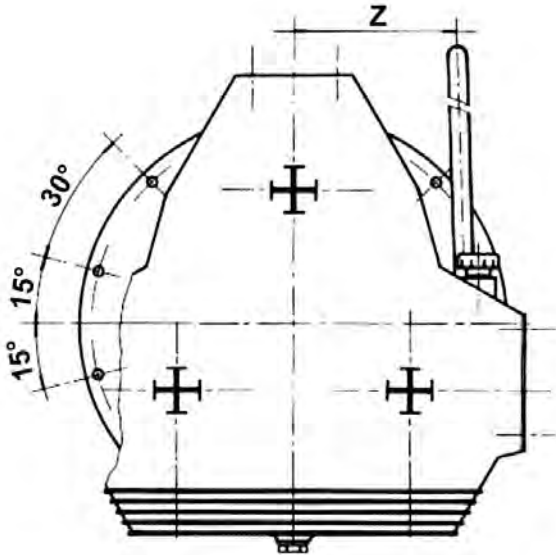

Clutch type	D	E	F	H	L	M	N	P	R	S	T	U	V	Z	K
BD 130	314.32	295.27	30	37	n. 8 holes Ø 10.5	54	114	55	55	110	224	100	324	160	78
BD 145	352.42	333.37	30	37	n. 8 holes Ø 10.5	39.7	114	55	55	110	224	100	324	160	78

SAE	DIMENSION			
	A	B	C	G
3	451,00	428,62	409,57	n. 12 holes Ø 11
4	403,22	381,00	361,95	n. 12 holes Ø 11

## AM 320 BDS

### Installation Drawing

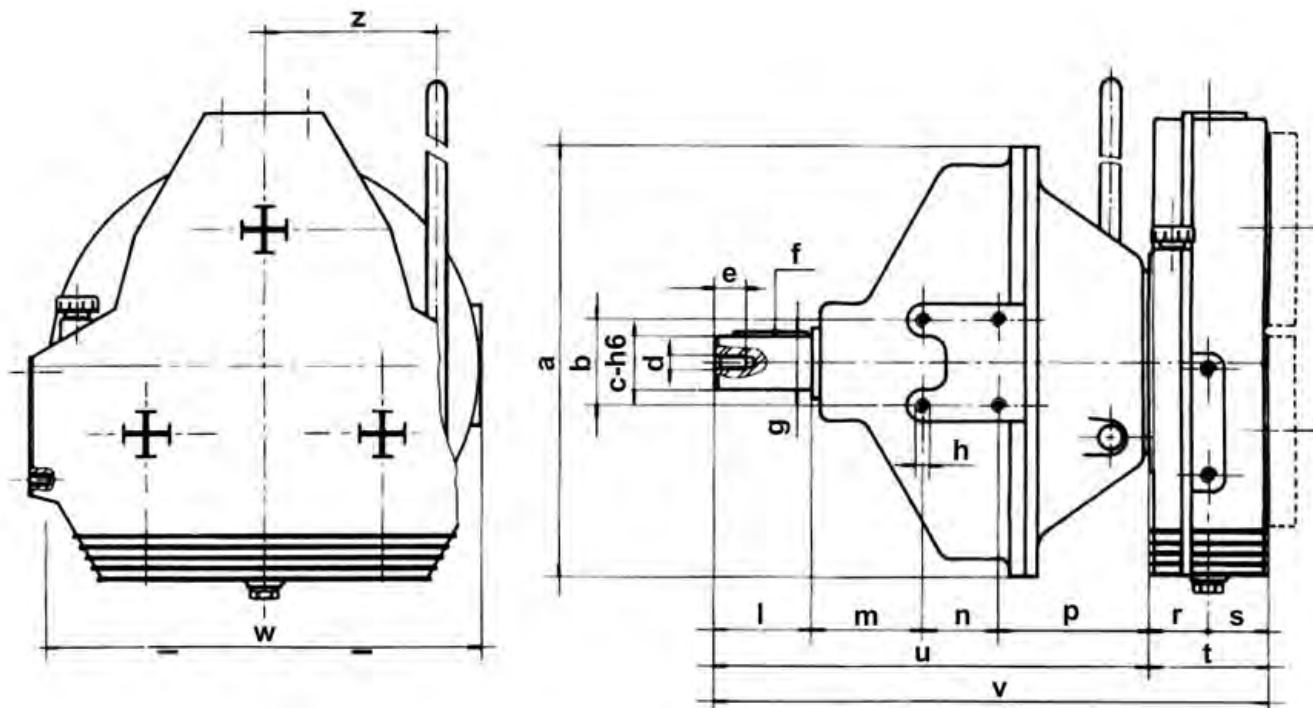

Clutch type	a	b	c	d	e	f	g	h	i	m	n	p	r	s	t	u	v	z	w
BDS 130	403	80	50	M14	30	14x9x70	54	M10	90	104	70	139	55	55	110	403	513	160	404
BDS 145	403	80	50	M14	30	14x9x70	54	M10	90	104	70	139	55	55	110	403	513	160	404

## AM 330 PUMP DRIVE

Max. Input Power 355 kW

### QUALITY IS STANDARD

- Cast iron housing
- Shaved gears
- Ball bearings
- Case-hardened shafts
- Viton seals on input shaft
- Output rotation opposite the direction of input rotation
- Gear ratios identical on all output
- Modular design



### AM 330 - TECHNICAL DATA

Ratio .....:1	Max. input torque Nm (lbf-ft)	Max. output torque per pump pad Nm (lbf-ft)	Max. input speed n /min.	Max. output speed n /min.	Oil quantity lt (gal)
0,49	1470 (1084)	360 (265)	2400	4898	2,5
0,58	1410 (1039)	410 (302)	2500	4310	2,0
0,67	1350 (995)	450 (332)	2650	3955	1,8
0,77	1270 (936)	490 (361)	2850	3701	1,8
0,83	1200 (884)	500 (368)	3000	3614	1,8
1,00	1080 (796)	540 (398)	3200	3200	1,4
1,30	980 (722)	640 (472)	3600	2769	1,4
1,50	900 (663)	675 (498)	3950	2633	1,2

### AM 330 - MOMENT OF INERTIA DATA

RATIO .....:1	B kg.m <sup>2</sup> (lb-ff <sup>2</sup> )	BD 130 kg.m <sup>2</sup> (lb-ff <sup>2</sup> )	BD 145 kg.m <sup>2</sup> (lb-ff <sup>2</sup> )	BD 290 kg.m <sup>2</sup> (lb-ff <sup>2</sup> )	BDS 130 kg.m <sup>2</sup> (lb-ff <sup>2</sup> )	BDS 145 kg.m <sup>2</sup> (lb-ff <sup>2</sup> )	BDS 290 kg.m <sup>2</sup> (lb-ff <sup>2</sup> )
0,49							
0,58							
0,67	0,1231 (2,92)	0,2606 (6,18)	0,3856 (9,15)	0,5731 (13,60)	0,3731 (8,85)	0,5606 (13,30)	0,7981 (18,94)
0,77	0,1114 (2,64)	0,2489 (5,91)	0,3739 (8,87)	0,5614 (13,32)	0,3614 (8,58)	0,5489 (13,03)	0,7864 (18,66)
1,00	0,0744 (1,77)	0,2119 (5,03)	0,3369 (7,99)	0,5244 (12,44)	0,3244 (7,70)	0,5119 (12,15)	0,7494 (17,78)
1,30	0,0668 (1,59)	0,2043 (4,85)	0,3293 (7,81)	0,5168 (12,26)	0,3168 (7,52)	0,5043 (11,97)	0,7418 (17,60)
1,50	0,0646 (1,53)	0,2022 (4,80)	0,3272 (7,76)	0,5146 (12,21)	0,3146 (7,47)	0,5021 (11,92)	0,7396 (17,55)

### AM 330 BD - BDS - CLUTCH CHARACTERISTICS

Clutch type	SAE size	Max input torque Nm	Max Speed n / min.	Power Kw
BD 130	3-4	330	3100	70
BD 145	3-4	450	3100	80
BD 290	1-2-3	880	2900	150
BDS 130	-	330	3100	70
BDS 145	-	450	3100	80
BDS 290	-	880	2900	150

## AM 330 B

### Basic Model - Installation Drawing

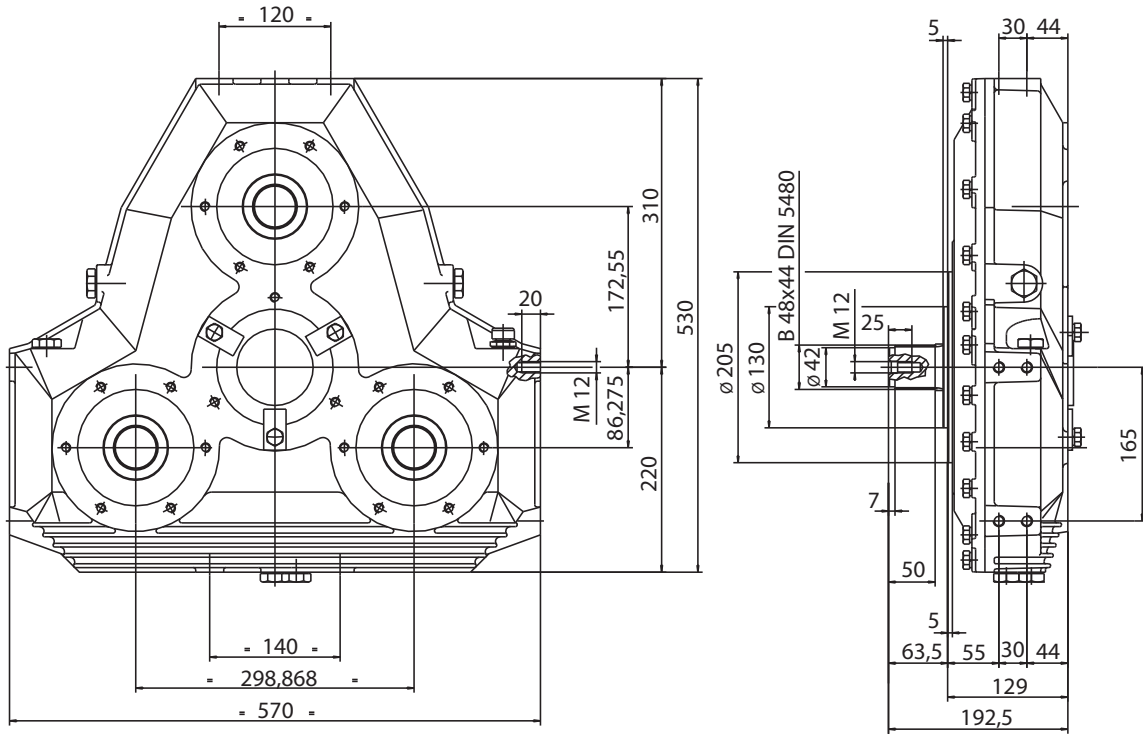

### AM 330 BD 130

With one plate 10" clutch

### AM 330 BD 145

With one plate 11" clutch

### AM 330 BD 290

With two plate 11" clutch

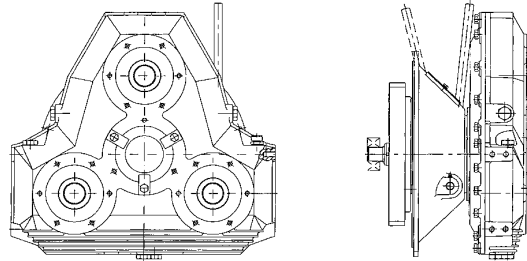

### AM 330 BDS 130

Independent mount with one plate 10" clutch

### AM 330 BDS 145

Independent mount with one plate 11" clutch

### AM 330 BDS 290

Independent mount with two plate 11" clutch

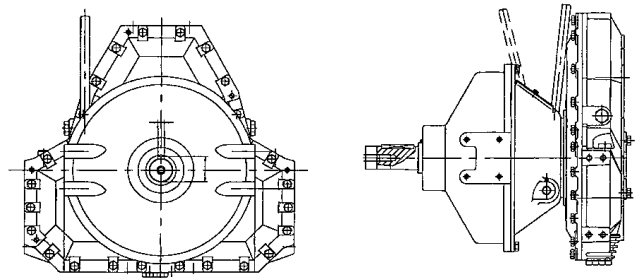

MODEL	WEIGHT kg (lbs)
AM 330 B	122 (261)
AM 330 BD 130	143 (315)
AM 330 BD 145	147 (324)
AM 330 BD 290	169 (373)
AM 330 BDS 130	174 (384)
AM 330 BDS 145	178 (392)
AM 330 BDS 290	196 (432)

## AM 330 BD

### Installation Drawing

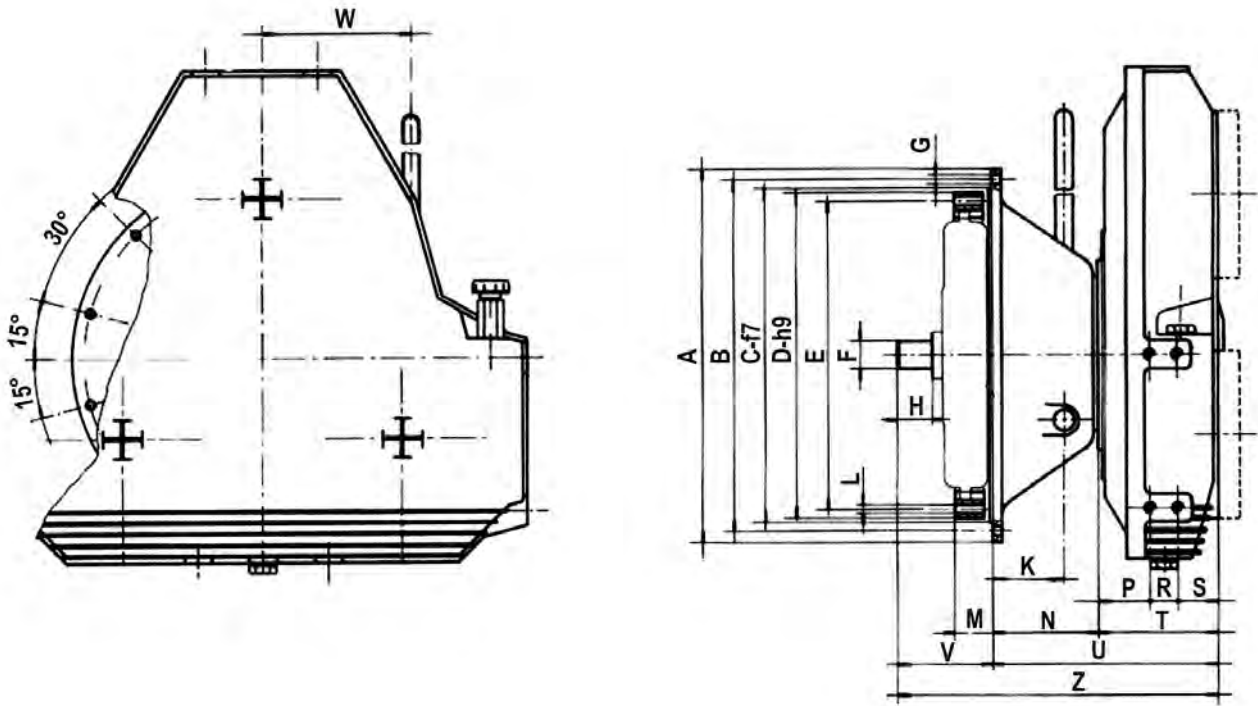

Clutch type	D	E	F	H	L	M	N	P	R	S	T	U	V	Z	K	W
<b>BD 130</b>	314,32	295,27	30	37	n. 8 holes Ø 10.5	54	114	55.5	30	43,5	129	243	100	343	78	160
<b>BD 145</b>	352,42	333,37	30	37	n. 8 holes Ø 10.5	39,7	114	55.5	30	43,5	129	243	100	343	78	160
<b>BD 290</b>	352.42	333.37	30	37	n. 8 holes Ø 10.5	39.7	147	55.5	30	43.5	129	276	100	376	111	205

SAE	DIMENSIONS			
	A	B	C	G
<b>1</b>	552,00	530,22	511,17	n. 12 holes Ø 11
<b>2</b>	489,00	466,72	447,67	n. 12 holes Ø 11
<b>3</b>	451,00	428.62	409,57	n. 12 holes Ø 11
<b>4</b>	403.22	381,00	361,95	n. 12 holes Ø 11

### AM 330 BDS

#### Installation Drawing

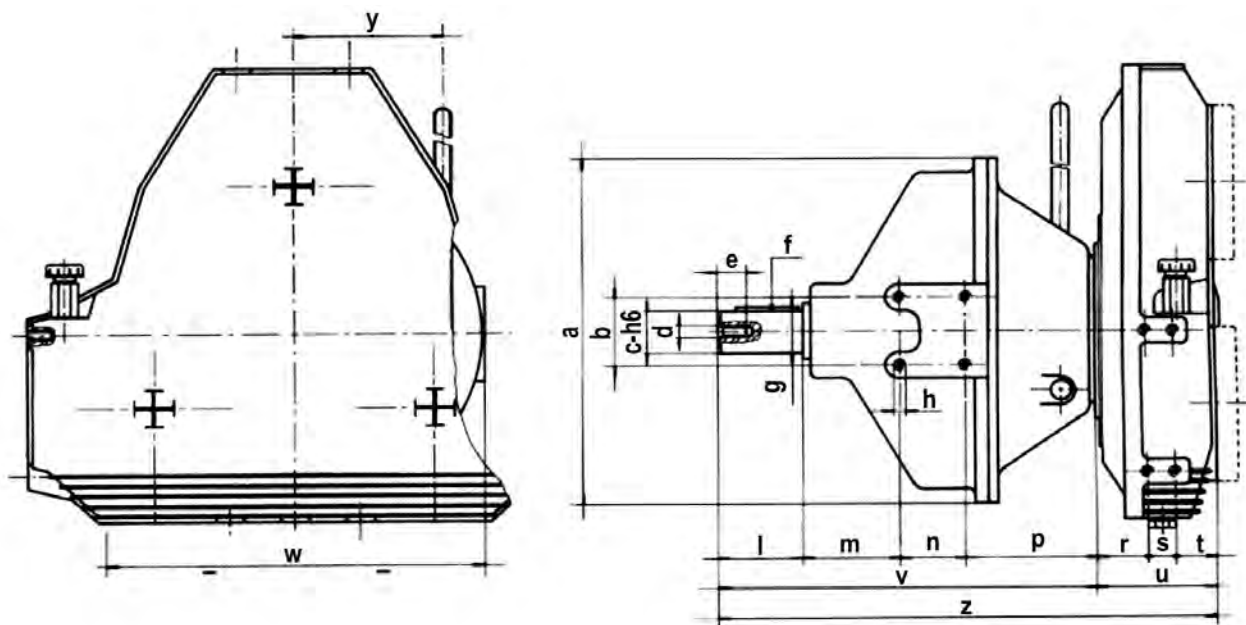

Clutch type	a	b	c	d	e	f	g	h	i	m	n	p	r	s	t	u	v	l	w	y
<b>BDS 130</b>	403	80	50	M 14	30	14x9x70	54	M10	90	104	70	139	55,5	30	43,5	129	403	532	404	160
<b>BDS 145</b>	403	80	50	M 14	30	14x9x70	54	M10	90	104	70	139	55,5	30	43,5	129	403	532	404	160
<b>BDS 290</b>	403	80	50	M 14	30	14x9x70	54	M10	90	104	70	172	55,5	30	43,5	129	436	565	404	160

## AM 345 PUMP DRIVE

Max. Input Power 430 kW

### QUALITY IS STANDARD

- Cast iron housing
- Case-hardened and ground spur gears
- Ball bearings
- Case-hardened shafts
- Viton seals on input shaft
- Output rotation opposite the direction of input rotation
- Gear ratios identical on all output
- Modular design



### AM 345 - TECHNICAL DATA

Ratio .....:1	Max. input torque Nm (lbf-ft)	Max. output torque per pump pad Nm (lbf-ft)	Max. input speed n /min.	Max. output speed n /min.	Oil quantity lt (gal)
0,51	2080 (1533)	530 (391)	1950	3823	5,5 (1,45)
0,58	2010 (1481)	580 (427)	2050	3534	5,0 (1,30)
0,67	1910 (1408)	640 (472)	2200	3284	4,4 (1,16)
0,76	1840 (1356)	700 (516)	2300	3026	4,0 (1,06)
0,89	1680 (1238)	750 (553)	2400	2696	3,7 (0,98)
1,00	1620 (1194)	810 (597)	2600	2600	3,6 (0,95)
1,31	1390 (1024)	910 (671)	3000	2290	3,0 (0,79)
1,48	1270 (936)	940 (693)	3200	2162	2,8 (0,74)

### AM 345 - MOMENT OF INERTIA DATA

RATIO .....:1	B kg.m <sup>2</sup> (lb-ff <sup>2</sup> )	BD 290 kg.m <sup>2</sup> (lb-ff <sup>2</sup> )	BD 2200 kg.m <sup>2</sup> (lb-ff <sup>2</sup> )	BD 3300 kg.m <sup>2</sup> (lb-ff <sup>2</sup> )	BDS 290 kg.m <sup>2</sup> (lb-ff <sup>2</sup> )	BDS 2200 kg.m <sup>2</sup> (lb-ff <sup>2</sup> )
0,51						
0,58						
0,67	0,2723 (6,46)	0,7223 (17,14)	2,0973 (49,77)	2,8223 (66,97)	0,9473 (22,48)	3,2723 (77,65)
0,76	0,2436 (5,78)	0,6936 (16,46)	2,0686 (49,09)	2,7936 (66,29)	0,9186 (21,80)	3,2436 (76,97)
1,00	0,1580 (3,75)	0,6080 (14,43)	1,9830 (47,06)	2,7080 (64,26)	0,8330 (19,77)	3,1580 (74,94)
1,31	0,1452 (3,45)	0,5952 (14,12)	1,9702 (46,75)	2,6952 (63,96)	0,8202 (19,46)	3,1452 (74,64)
1,48	0,1405 (3,33)	0,5904 (14,01)	1,9654 (46,64)	2,6904 (63,84)	0,8154 (19,35)	3,1404 (74,52)

### AM 345 BD - BDS - CLUTCH CHARACTERISTICS

Clutch type	SAE size	Max input torque Nm	Max Speed n / min.	Power Kw
BD 290	1-2-3	880	2900	150
BD 2200	1	1960	2400	230
BD 3300	1	2940	2400	320
BDS 290		880	2900	150
BDS 2200	-	1960	2400	230
BDS 3300	-	2940	2400	320



## AM 345 B

### Basic Model - Installation Drawing

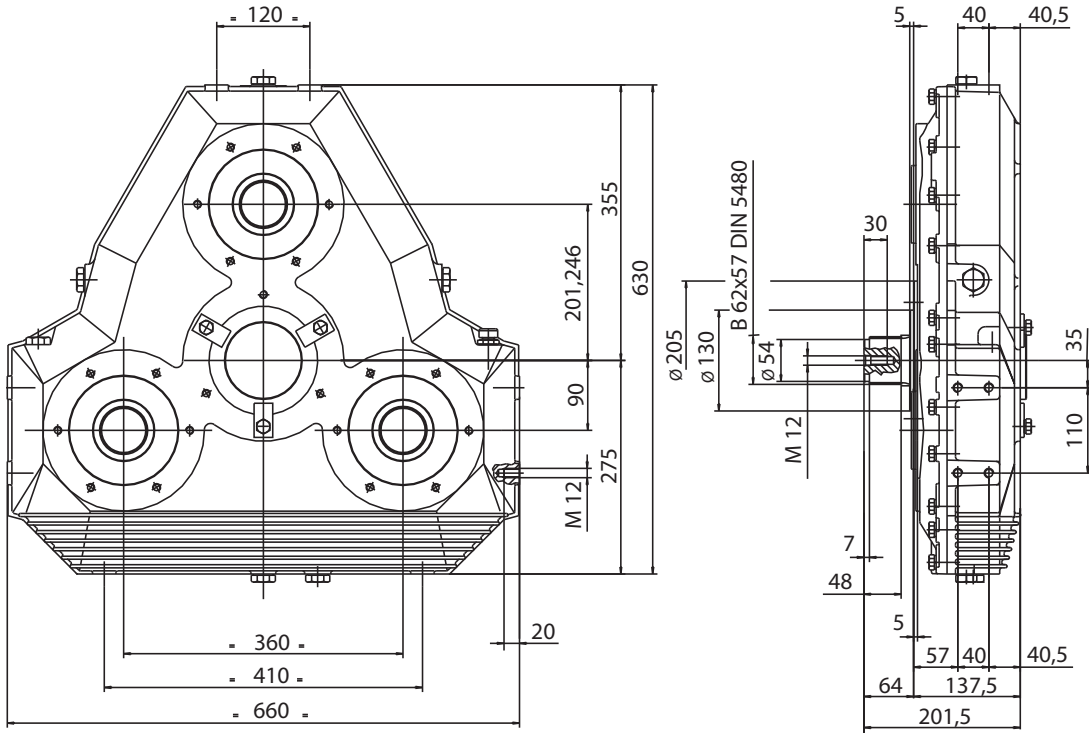

### AM 345 BD 290

With one plate 11" clutch

### AM 345 BD 2200

With two plate 14" clutch

### AM 345 BD 3300

With three plate 14" clutch

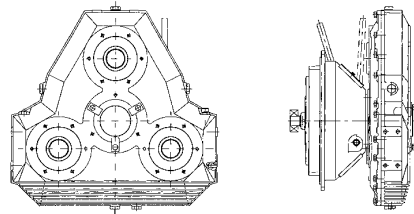

### AM 345 BDS 290

Independent mount with two plate 11" clutch

### AM 345 BDS 2200

Independent mount with two plate 14" clutch

### AM 345 BDS 3300

Independent mount with three plate 14" clutch

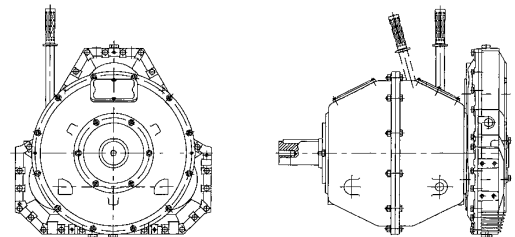
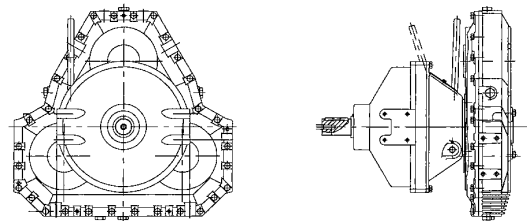

MODEL	WEIGHT kg (lbs)
AM 345 B	154 (339)
AM 345 BD 290	188 (414)
AM 345 BD 2200	255 (562)
AM 345 BD 3300	298 (657)
AM 345 BDS 290	215 (474)
AM 345 BDS 2200	365 (805)
AM 345 BDS 3300	389 (857)

## AM 345 BD

### Installation Drawing

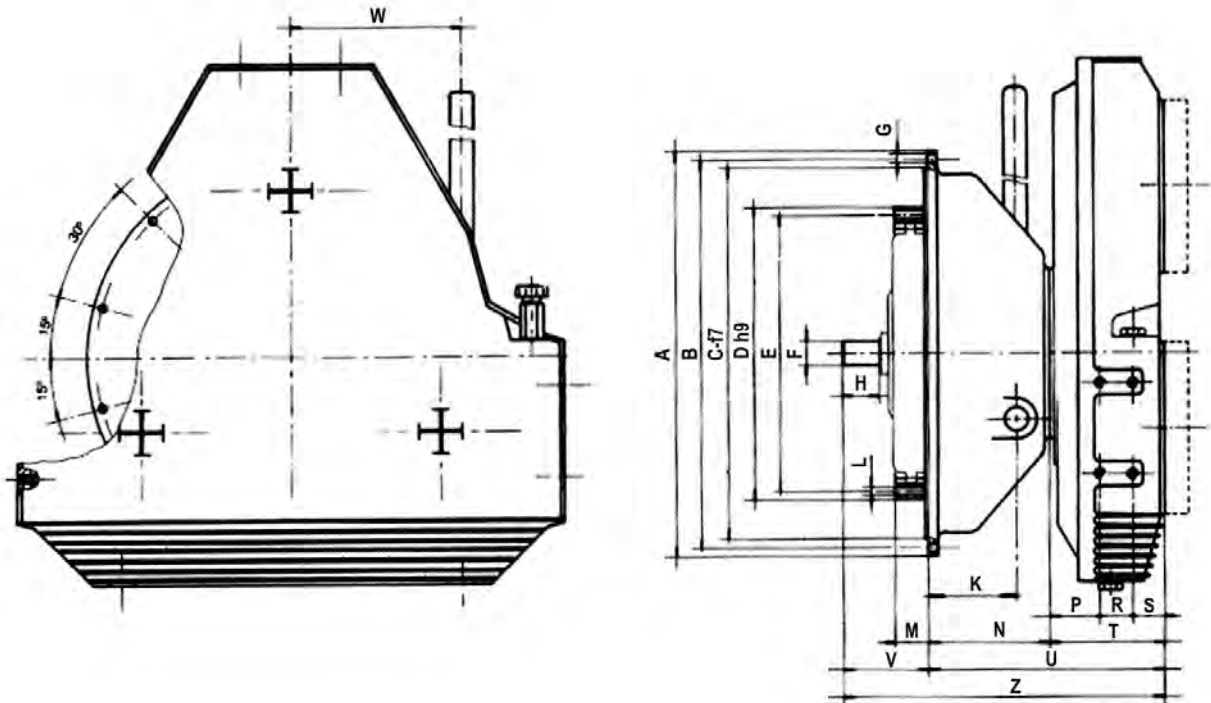

Clutch type	D	E	F	H	L	M	N	P	R	S	T	U	V	Z	K	W
BD 290	352,42	333,37	30	37	n. 8 holes Ø 10.5	39,7	147	57	40	40	137	284	100	384	78	160
BD 2200	466,72	438,15	35	37	n. 8 holes Ø 10.5	25,4	236	52	40	40	132	368	100	468	179	215
BD 3300	466,72	438,15	35	37	n. 8 holes Ø 10.5	25,4	264	52	40	40	132	396	100	496	207	215

SAE	DIMENSIONS			
	A	B	C	G
1	552	530,22	511,17	n. 12 holes Ø 12
2	489	466,72	447,67	n. 12 holes Ø 11
3	451	428,62	409,57	n. 12 holes Ø 11

### AM 345 BDS

#### Installation Drawing

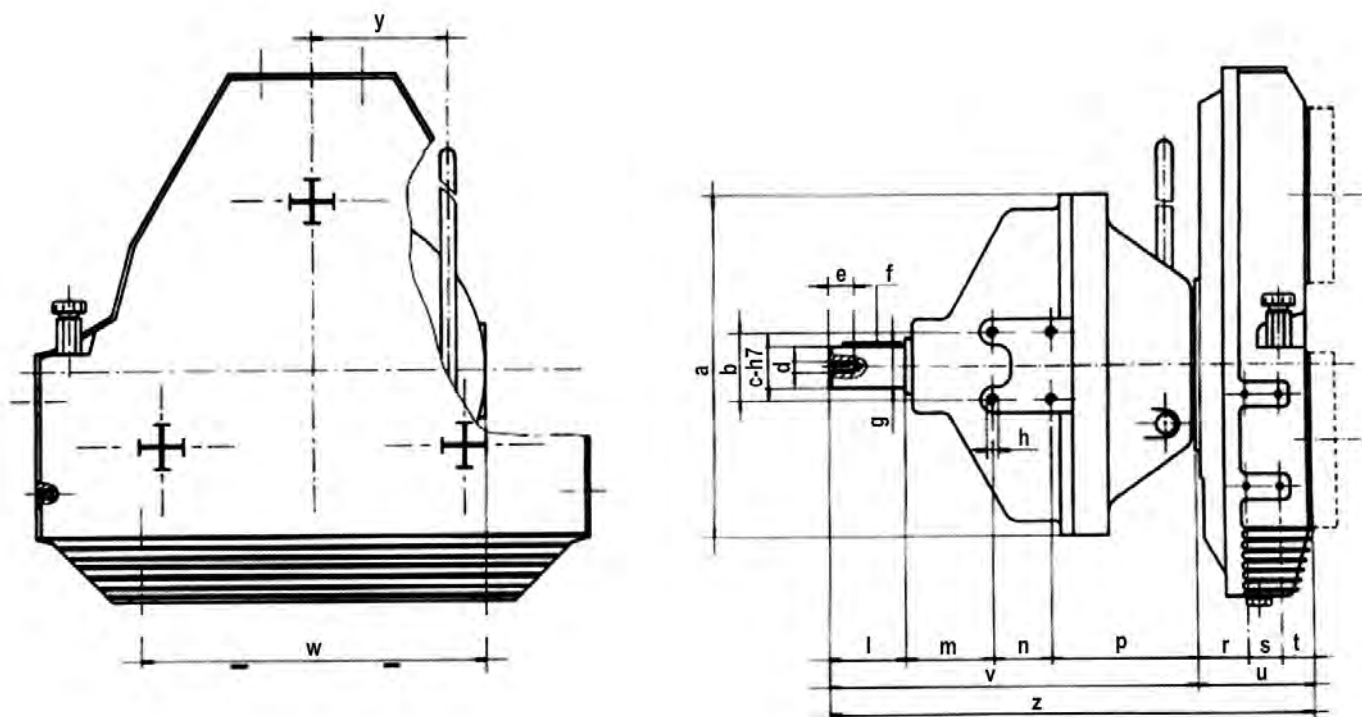

Clutch type	a	b	c	d	e	f	g	h	i	m	n	p	r	s	t	u	v	l	w	y
<b>BDS 290</b>	403	80	50	M 14	30	14x9x70	54	M10	90	104	70	172	57	40	40	137	436	573	404	160
<b>BDS 2200</b>	552	-	80	M 20	45	24x14x120	87	-	135	-	-	-	52	40	40	132	634	766	-	215
<b>BDS 3300</b>	552	-	80	M 20	45	24x14x120	87	-	135	-	-	-	52	40	40	132	662	794	-	215

### AM 450 PUMP DRIVE

Max. Input Power 640 kW

#### QUALITY IS STANDARD

- Cast iron housing
- Case-hardened and ground spur gears
- Ball bearings
- Case-hardened shafts
- Viton seals on input shaft
- Output rotation opposite the direction of input rotation
- Gear ratios identical on all output
- Modular design



#### AM 450 - TECHNICAL DATA

Ratio .....:1	Max. input torque Nm (lbf-ft)	Max. output torque per pump pad Nm (lbf-ft)	Max. input speed n /min.	Max. output speed n /min.	Oil quantity lt (gal)
<b>0,50</b>	4200 (3095)	1050 (774)	1800	3600	2,8 (0,74)
<b>0,67</b>	3780 (2786)	1250 (921)	2000	2985	2,5 (0,66)
<b>0,77</b>	3065 (2259)	1180 (870)	2100	1617	2,5 (0,66)
<b>0,89</b>	2580 (1900)	1150 (848)	2250	2000	2,3 (0,61)
<b>1,00</b>	2600 (1916)	1300 (958)	2400	2400	2,3 (0,61)

#### AM 450 - MOMENT OF INERTIA DATA

RATIO .....:1	B kg.m <sup>2</sup> (lb-ff <sup>2</sup> )	BD 290 kg.m <sup>2</sup> (lb-ff <sup>2</sup> )	BD 2200 kg.m <sup>2</sup> (lb-ff <sup>2</sup> )	BD 3300 kg.m <sup>2</sup> (lb-ff <sup>2</sup> )	BDS 290 kg.m <sup>2</sup> (lb-ff <sup>2</sup> )	BDS 2200 kg.m <sup>2</sup> (lb-ff <sup>2</sup> )
<b>0,67</b>	0,6413 (15,22)	1,1088 (26,32)	2,4663 (58,53)	3,1913 (75,73)	1,3163 (31,24)	3,6413 (86,41)
<b>0,77</b>	0,5777 (13,71)	1,0452 (24,80)	2,4027 (57,02)	3,1277 (74,22)	1,2527 (29,73)	3,5777 (84,90)
<b>0,89</b>	0,4527 (10,74)	0,9202 (21,84)	2,2777 (54,05)	3,0027 (71,26)	1,1277 (26,76)	3,4527 (81,93)
<b>1,00</b>	0,4445 (10,55)	0,8945 (21,23)	2,2695 (53,86)	2,9945 (71,06)	1,1195 (26,57)	3,4445 (81,74)

#### AM 450 BD - BDS - CLUTCH CHARACTERISTICS

Clutch type	SAE size	Max input torque Nm	Max Speed n / min.	Power Kw
<b>BD 290</b>	1-2-3	880	2900	150
<b>BD 2200</b>	1	1960	2400	230
<b>BD 3300</b>	1	2940	2400	320
<b>BDS 290</b>	-	880	2900	150
<b>BDS 2200</b>	-	1960	2400	230
<b>BDS 3300</b>	-	2940	2400	320

## AM 450 B

### Basic Model - Installation Drawing

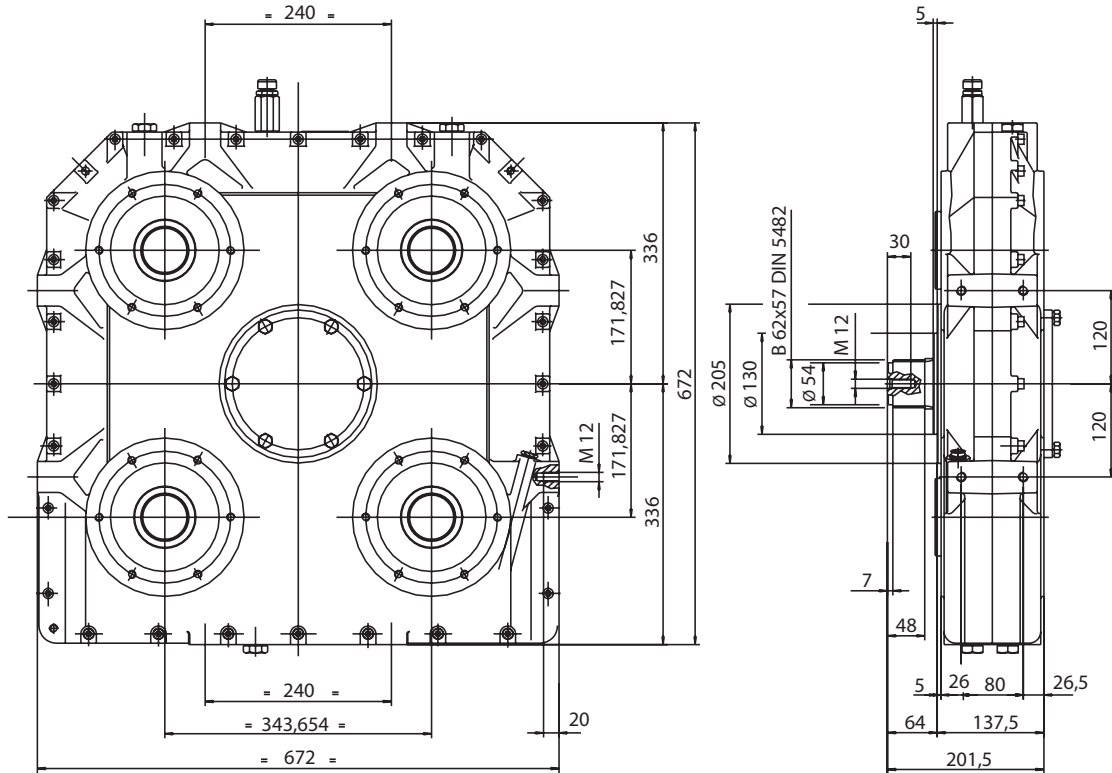

## AM 450 BD 290

With two plate 11" clutch

## AM 450 BD 2200

With two plate 14" clutch

## AM 450 BD 3300

With three plate 14" clutch

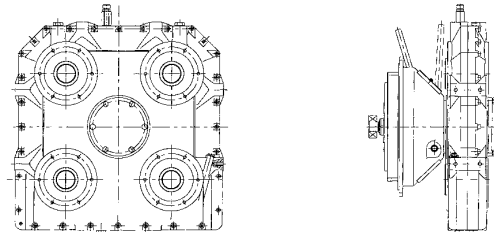

## AM 450 BDS 290

Independent mount with two plate 11" clutch

## AM 450 BDS 2200

Independent mount with two plate 14" clutch

## AM 450 BDS 3300

Independent mount with three plate 14" clutch

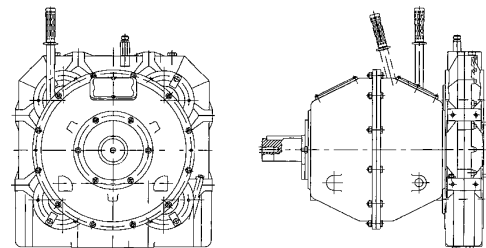
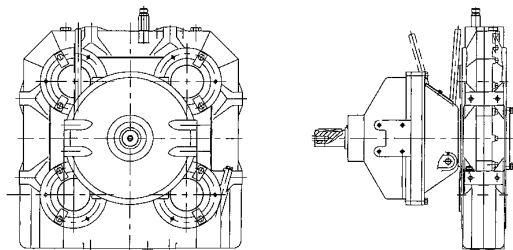

MODEL	WEIGHT kg (lbs)
AM 450 B	205
AM 450 BD 290	271
AM 450 BD 2200	338
AM 450 BD 3300	381
AM 450 BDS 290	298
AM 450 BDS 2200	448
AM 450 BDS 3300	472

## AM 450 BD

### Installation Drawing

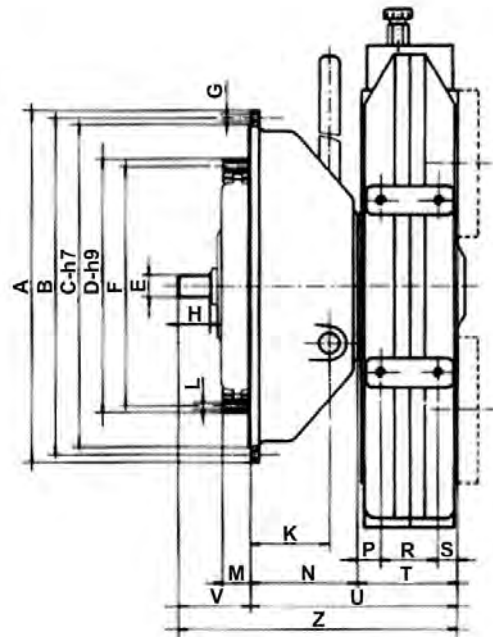
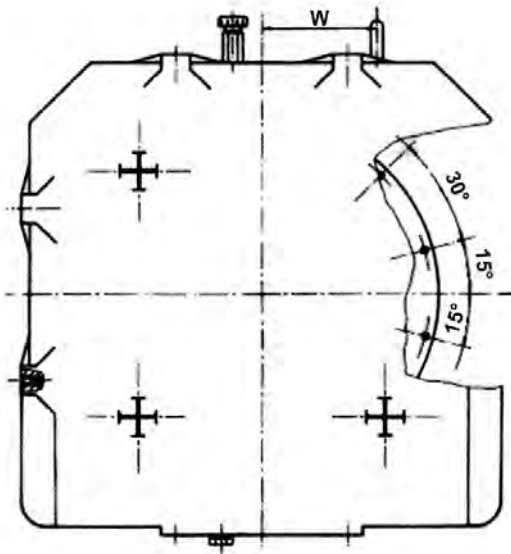

Clutch type	D	E	F	H	L	M	N	P	R	S	T	U	V	Z	K	W
<b>BD 290</b>	352,42	333,37	30	37	n. 8 holes Ø 10.5	39,7	147	31	80	26	137	284	100	384	78	160
<b>BD 2200</b>	466,72	438,15	35	37	n. 8 holes Ø 10.5	25,4	236	26	80	26	132	368	100	468	179	215
<b>BD 3300</b>	466,72	438,15	35	37	n. 8 holes Ø 10.5	25,4	264	26	80	26	132	396	100	496	207	215

SAE	DIMENSIONS			
	A	B	C	G
1	552	530,22	511,17	n. 12 holes Ø 12
2	489	466,72	447,67	n. 12 holes Ø 11
3	451	428,62	409,57	n. 12 holes Ø 11

### AM 450 BDS

#### Installation Drawing

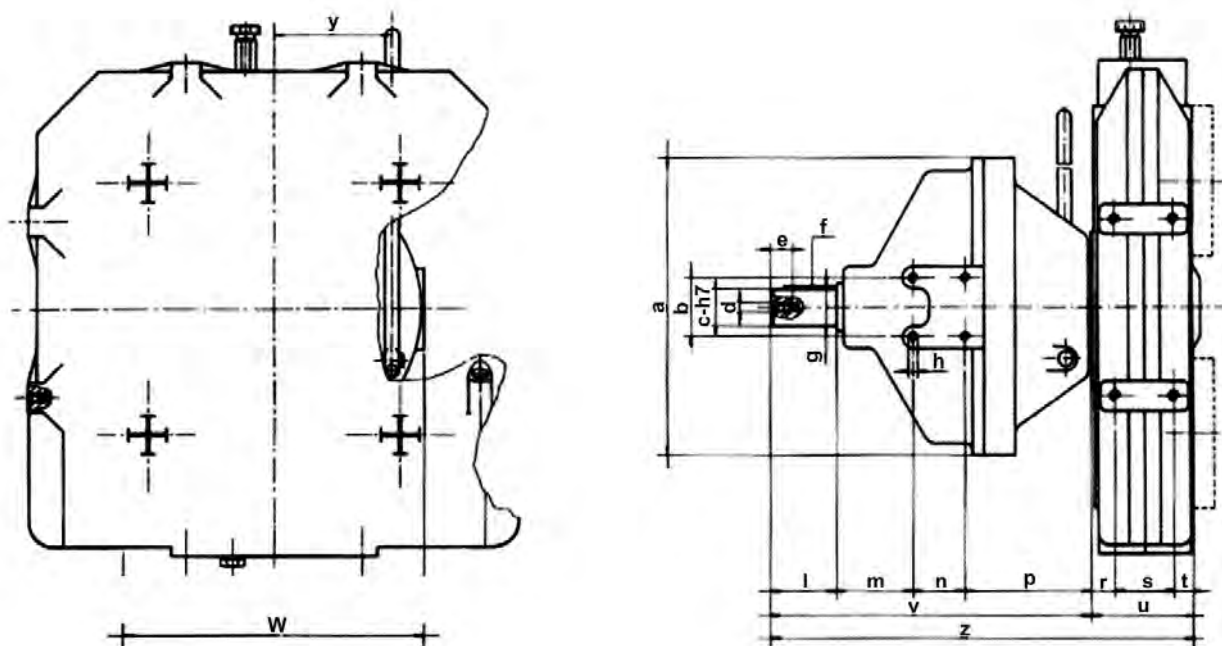

Clutch type	a	b	c	d	e	f	g	h	i	m	n	p	r	s	t	u	v	l	w	y
<b>BDS 290</b>	403	80	50	M 14	30	14x9x70	54	M 10	90	104	70	172	31	80	26	137	436	573	404	160
<b>BDS 2200</b>	552	-	80	M 20	45	24x14x120	87	-	135	-	-	-	26	80	26	132	634	766	-	215
<b>BDS 3300</b>	552	-	80	M 20	45	24x14x120	87	-	135	-	-	-	26	80	26	132	662	794	-	-



## AM 365 PUMP DRIVE

Max. Input Power 670 kW

### QUALITY IS STANDARD

- Cast iron housing
- Case-hardened and ground spur gears
- Ball bearings
- Case-hardened shafts
- Viton seals on input shaft
- Output rotation opposite the direction of input rotation
- Gear ratios identical on all output
- Modular design

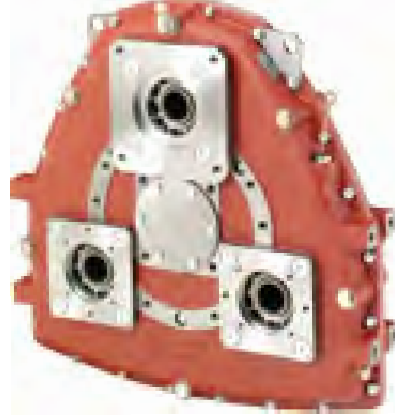

### AM 365 - TECHNICAL DATA

Ratio .....:1	Max. input torque Nm (lbf-ft)	Max. output torque per pump pad Nm (lbf-ft)	Moment of inertia kg.m <sup>2</sup> (lb.ft <sup>2</sup> )	Max. input speed n /min.	Max. output speed n /min.	Oil quantity lt (gal)	WEIGHT * kg (lbs)
0,69	3480 (2564)	1200 (884)	0,4391 (10,42)	1800	2608	14,5 (3,84)	215 (474)
0,81	3460 (2550)	1400 (1032)	0,4255 (10,10)	2100	2593		
0,92	3040 (2240)	1400 (1032)		2100	2593		
1,00	2900 (2137)	1450 (1068)	0,3626 (8,60)	2200	2200		
1,09	2660 (1960)	1450 (1068)		2200	2018		
1,23	2600 (1916)	1600 (1180)	0,3428 (8,13)	2400	1951		
1,45	2350 (1731)	1700 (1253)	0,2794 (6,63)	2500	1724		

\* Weight with SAE 1 housing: 260 Kg. (573 lbs)

### AM 365 B

#### Basic Model - Installation Drawing

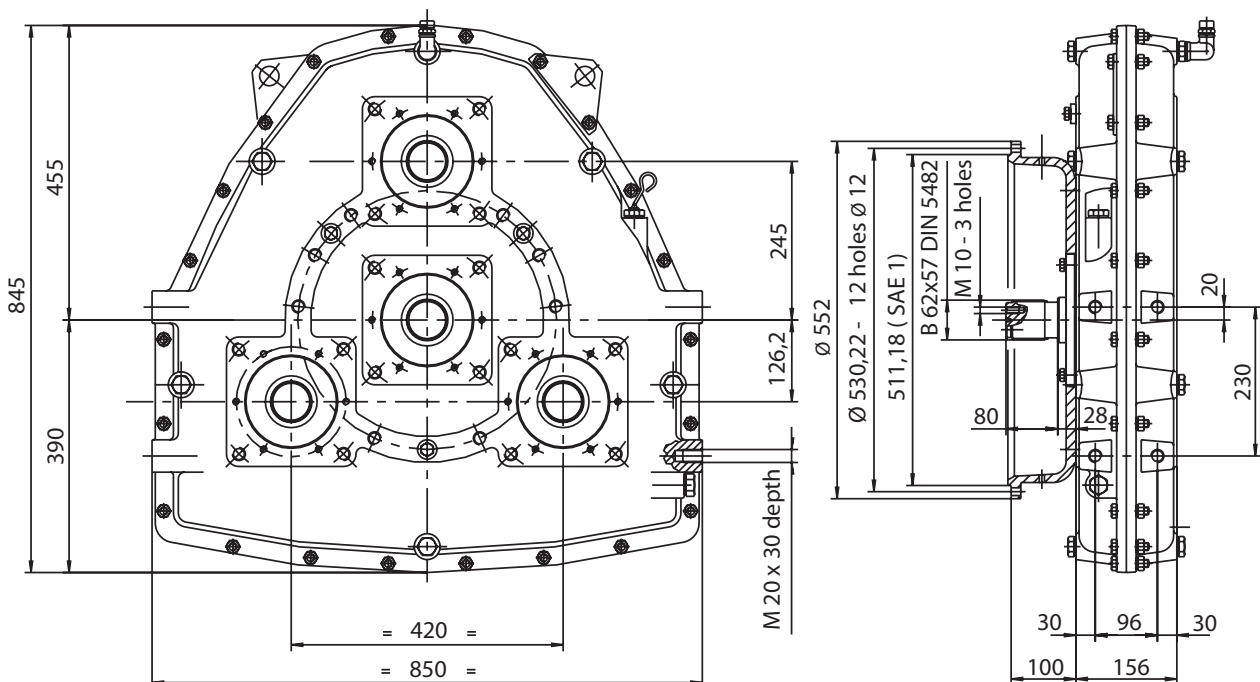

## AM 480 PUMP DRIVE

Max. Input Power 700 kW

### QUALITY IS STANDARD

- Cast iron housing
- Case-hardened and ground spur gears
- Ball bearings
- Case-hardened shafts
- Viton seals on input shaft
- Output rotation opposite the direction of input rotation
- Gear ratios identical on all output
- Modular design

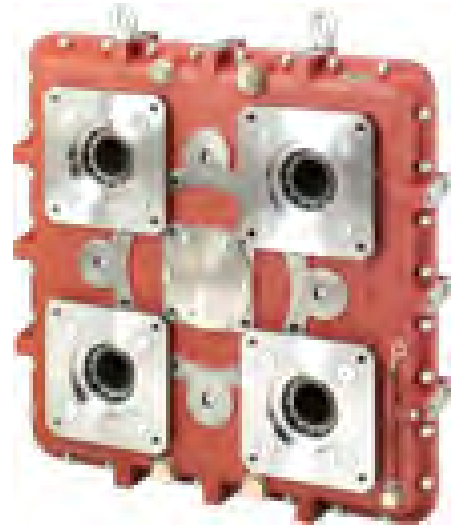

### AM 480 - TECHNICAL DATA

Ratio ....:1	Max. input torque Nm (lbf-ft)	Max. output torque per pump pad Nm (lbf-ft)	Moment of inertia kg.m <sup>2</sup> (lb.ft <sup>2</sup> )	Max. input speed n /min.	Max. output speed n /min.	Oil quantity lt (gal)	WEIGHT * kg (lbs)
0,72	4400 (3242)	1600 (1179)	1,4705 (34,90)	1700	2361	7,3 (1,93)	350 (772)
0,87	4000 (2948)	1750 (1290)	1,3524 (32,09)	1800	2068	7,0 (1,85)	
1,00	3800 (2800)	1900 (1400)	1,2394 (29,41)	1800	1800	6,9 (1,82)	
1,15	3490 (2572)	2000 (1474)	1,1568 (27,45)	2000	1739	6,7 (1,77)	

\* Weight with SAE 1 housing: 395 Kg. (871 lbs)

### AM 480 B

#### Basic Model - Installation Drawing

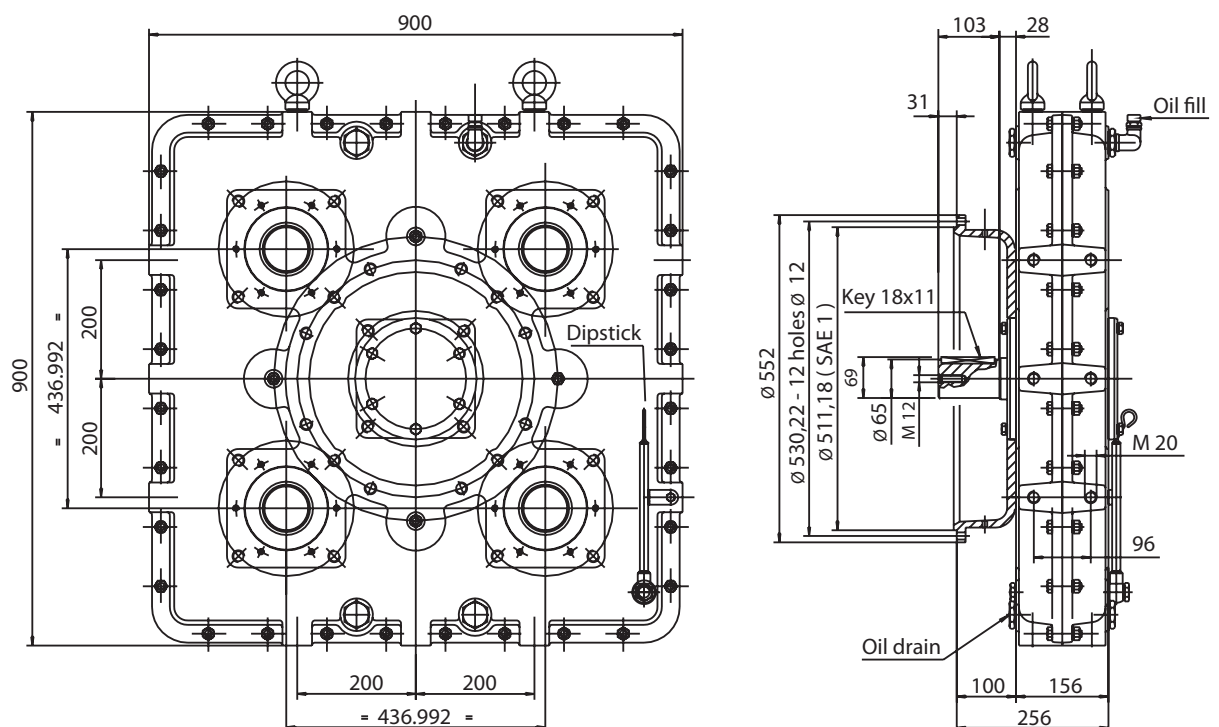

# **SPEED REDUCING (INCREASING) GEARBOXES**



## RM SPEED REDUCING (INCREASING) GEARBOXES

### DESCRIPTION

RM gearboxes have been specially designed to couple Diesel engines; they allow to operate an utilizer (water pump, compressor, fan...) requiring an input speed different from the Diesel engine speed.

Constructively the RM gearboxes consist of:

- cast iron casing (aluminium alloy on RM 20)
- helical tooth, case-hardened, shaved (grinded on RM 150) gears
- shafts are manufactured from high quality steel, case hardened
- taper roller bearing on output shaft
- the input shaft is supported by a single bearing inside the casing and therefore it must be driven by a pilot bearing assembled on the flywheel, in case of close coupling to Diesel prime mover.
- RM series includes 6 models and each of them may be provided with an output rotation direction equal to that of input (RM ... S), or with opposite direction to that of input (RM ... D).
- RM ... D: reverse rotation units have a primary gear on the input shaft driving directly onto the secondary gear powering the output shaft.
- RM ... S: same rotation version have an idler gear between primary and secondary gears.
- RM gearboxes may be equipped for close coupling to Diesel engines with:
  - overcenter clutch (BD) with SAE housing
  - SAE housing and rigid or flexible coupling (GR, GE).
- Freestanding mounting is possible in the BDS execution.

### TECHNICAL DATA

#### - Ratio I

It represents the ratio between the input speed (Diesel engine speed) and the output speed (utilizer speed).

Ratios lower than 1 indicate a gearbox performing as speed increaser, higher than 1 as speed reducer.

#### - Max. input torque Me

It is the maximum torque wich may be transmitted on input, corresponding to a theoretical unlimited gear life and to a bearing life (L10) of 5000 hours at least, with an input speed of 2000 RPM. For clutch/gearbox combination, the max input torque may be limited by the clutch capacity.

#### - Max. input speed Ne

It is the maximum speed at the input shaft. For clutch/gearbox combination, the max input speed may be limited by the clutch.

#### - Max. power P

It is the maximum power that may be transmitted under normal conditions, without an oil cooling system.

The values shown are only indicative, many external factors may create much influence, such as: air temperature, possibility of air circulation, environment conditions.

When the power is higher than the listed value a cooling system is necessary.

## SELECTION

RM unit selection should be made by taking the input torque and be multiplying it by the service factor:

**1,0** - light duty (centrifugal pumps, fans).

**1,5** - duty (4 cyl. compressors, conveyors, hydraulic pumps).

**2,0** - heavy duty (2 cyl. compressors, mixers, presses).

**2,5** - very heavy duty (1 cyl. compressors, mills).

The resulting torque is to be lower than the listed value (**Me**) for selected gearbox type and ratio.

For clutch gearbox combination, the max input torque may be limited by the clutch capacity: see table

## TECHNICAL DATA FOR CLUTCHES.

## LUBRIFICATION

- Use SAE 90 with EP additives - units are supplied without oil; before use fill to the maximum level mark on dipstick.
- Oil must be replaced after the first 100 working hours. Subsequent oil changes should be made every 1000 hours or every 12 months, whichever is the sooner.
- Check regularly the oil level.

## COOLING

The maximum oil temperature during continuous operation must not exceed 95°C.

It is wise to check this temperature during the first working hours.

If recommended maximum power limits are to be exceeded, RM models 120 and 150 are available with oil cooling system.

## RM SPEED REDUCING (INCREASING) GEARBOXES TECHNICAL DATA

Gearbox Type	Ratio	Max input torque Me (Nm)	Max input speed Ne (n/min.)	Max power P (Kw)	Equipment		
					Housing size	Clutch size	Freestanding clutch
RM 20 D	0,57	75	3500	15	SAE 5-4-3	6-1/2" 7-1/2" 8"	BDS 112
	1,00	75	3500				
	2,00	55	3500				
	2,71	50	3500				
RM 20 S	0,64	75	2800	12			
	1,89	55	3500				
	2,47	50	3500				
RM 45 D	0,67	165	2800	30	SAE 5-4-3	6-1/2" 7-1/2" 8"	BDS 118
	1,00	160	3500				
	2,00	120	3500				
	2,88	100	3500				
	3,40	80	3500				
	4,00	80	3500				
4,09	70	3500					
RM 45 S	0,57	160	2700	24			
	1,50	130	3500				
	1,81	110	3500				
	2,65	90	3500				
	4,09	70	3500				
RM 70 D	0,58	290	2400	48	SAE 4-3	10"	BDS 130
	1,00	290	2600				
	1,53	250	2400				
	2,00	210	3200				
	2,45	190	3200				
	3,00	170	3200				
3,75	155	3200					
RM 70 S	0,50	280	2400	38			
	0,63	280	2600				
	0,70	260	2700				
	1,32	220	3200				
	1,88	200	3200				
	2,73	160	3200				
3,25	120	3200					
RM 100 D	0,60	400	2400	75	SAE 4-3	10" 11-1/2"	BDS 145
	0,67	400	2500				
	1,00	400	3000				
	1,20	380	3000				
	1,50	350	3000				
	2,00	320	3000				
	3,00	260	3000				
	3,66	230	3000				
5,00	230	3000					
RM 100 S	0,51	400	2000	60			
	0,81	380	2700				
	1,23	380	3000				
	1,50	350	3000				
	1,86	320	3000				
	2,80	260	3000				
	4,21	230	3000				

## RM SPEED REDUCING (INCREASING) GEARBOXES TECHNICAL DATA

Gearbox Type	Ratio	Max input torque Me (Nm)	Max input speed Ne (n/min.)	Max power P (Kw)	Equipment		
					Housing size	Clutch size	Freestanding clutch
RM 120 D	0,50	1000	2500	85	SAE 4-3-2-1	11-1/2"	BDS 145 BDS 290
	1,02	880	2500				
	1,70	740	2500				
	2,00	700	2500				
	3,00	510	2500				
	3,55	450	2500				
RM 120 S	0,67	830	2000	68	SAE 4-3-2-1	11-1/2"	BDS 145 BDS 290
	1,50	500	2500				
	2,00	480	2500				
	2,60	480	2500				
	2,80	480	2500				
	3,00	480	2500				
RM 150 D	0,66	1500	2000	100	SAE 3-2-1	11-1/2" 14"	BDS 290 BDS 2200
	1,02	1450	2500				
	1,47	1250	2500				
	2,00	1090	2500				
	3,04	850	2500				
RM 150 S	1,51	950	2500	80	SAE 3-2-1	11-1/2" 14"	BDS 290 BDS 2200
	1,96	950	2500				
	2,70	640	2500				

## CLUTCHES TECHNICAL DATA

Clutch type	Clutch size	SAE Housing size	Max. torque Me (Nm)	Max. speed Ne (n / min)
BD 110	6-1/2" - (7-1/2")	5 - 4	170	3500
BD 112	8" - (7-1/2")	4 - 3	200	3500
BDS 112	-	-	200	3500
BD 118	8"	4 - 3	240	3500
BDS 118	-	-	240	3500
BD 130	10"	4 - 3	330	3100
BDS 130	-	-	330	3100
BD 145	11-1/2"	4 - 3	450	3100
BDS 145	-	-	450	3100
BD 290	11-1/2"	3 - 2 - 1	880	2900
BDS 290	-	-	880	2900
BD 2200	14"	1	1960	2400
BDS 2200	-	-	1960	2400



## RM...BD SPEED REDUCING (INCREASING) GEARBOXES

### Installation Drawing

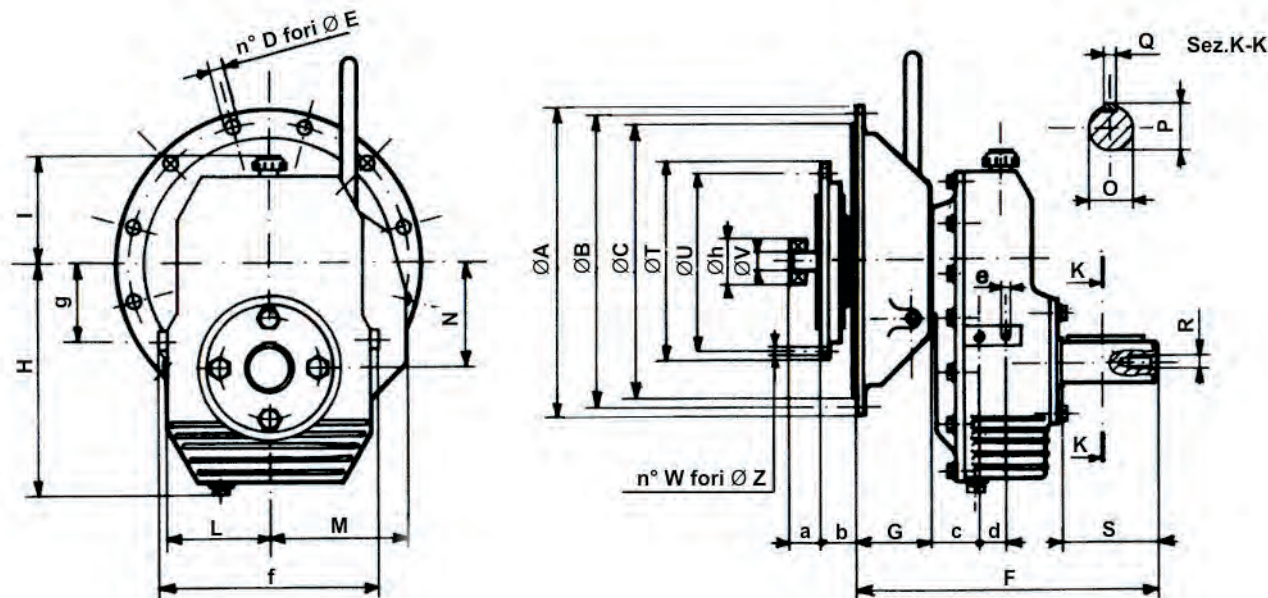

Gearbox type	FLYWEEL SIZE	HOUSING SAE	F	G	H	I	L	M	N	O	P	Q	R
RM 20...BD 110	6-½"	5	265,5	108,5	164	137	82	110	67,5	30	33	8	M 10
RM 20...BD 112	8"	3-4	237	80	164	137	82	110	67,5	30	33	8	M 10
RM 45...BD 110	6-½"	5	309,5	108,5	215	160	103	130	88,5	40	43,5	12	M 10
RM 45...BD 118	8"	3-4	281	80	215	160	103	130	88,5	40	43,5	12	M 10
RM 70...BD 130	10"	3-4	336	114	273	170	125	158	121,5	50	54	14	M 12
RM 100...BD 130	10"	3-4	406	114	283	176	135	183	135	60	65	16	M 14
RM 100...BD 145	11½"	3-4	406	114	283	176	135	183	135	60	65	16	M 14
RM 120...BD 145	11½"	3-4	454	114	337	208	170	220	160	70	76	20	M 14
RM 120...BD 290	11½"	1-2-3	487	147	337	208	170	220	160	70	76	20	M 14
RM 150...BD 290	11½"	1-2-3	549	147	384	229	190	220	189	80	87	24	M 20
RM 150...BD 2200	14"	1	633	236	384	229	190	220	189	80	87	24	M 20

Gearbox type	S	T	U	V	W	Z	a	b	c	d	e	f	g	h
RM 20...BD 110	50	215,9	200	25	6	8,5	41,4	30	-	-	-	-	-	52
RM 20...BD 112	50	263,52	244,5	25	6	11	38	62	-	-	-	-	-	62
RM 45...BD 110	70	215,9	200	25	6	8,5	41,4	30	-	-	-	-	-	52
RM 45...BD 118	70	263,52	244,5	25	6	10,5	38	62	-	-	-	-	-	62
RM 70...BD 130	80	314,32	295,3	30	8	10,5	46	54	-	-	-	-	-	72
RM 100...BD 130	120	314,32	295,3	30	8	10,5	46	54	-	-	-	-	-	72
RM 100...BD 145	120	352,42	333,4	30	8	10,5	60	40	-	-	-	-	-	72
RM 120...BD 145	140	352,42	333,4	30	8	10,5	60	40	68	50	M 12	380	238	72
RM 120...BD 290	140	352,42	333,4	30	8	10,5	60	40	68	50	M 12	380	238	72
RM 150...BD 290	140	352,42	333,4	30	8	10,5	60	40	95	50	M 12	420	159	72
RM 150...BD 2200	140	466,72	438,2	35	8	13	75	25	95	50	M 12	420	159	80

SAE Size	A	B	C	D	E
1	352	530.22	511.20	12	12
2	469	465.72	447.67	12	11
3	451	428.62	409.57	12	11
4	403	381.00	361.95	12	11
5	356	333.37	314.32	8	11

All quoted dimensions are valid also for flexible or rigid coupling fitting.

## RM... BDS SPEED REDUCING (INCREASING) GEARBOXES

Installation Drawing

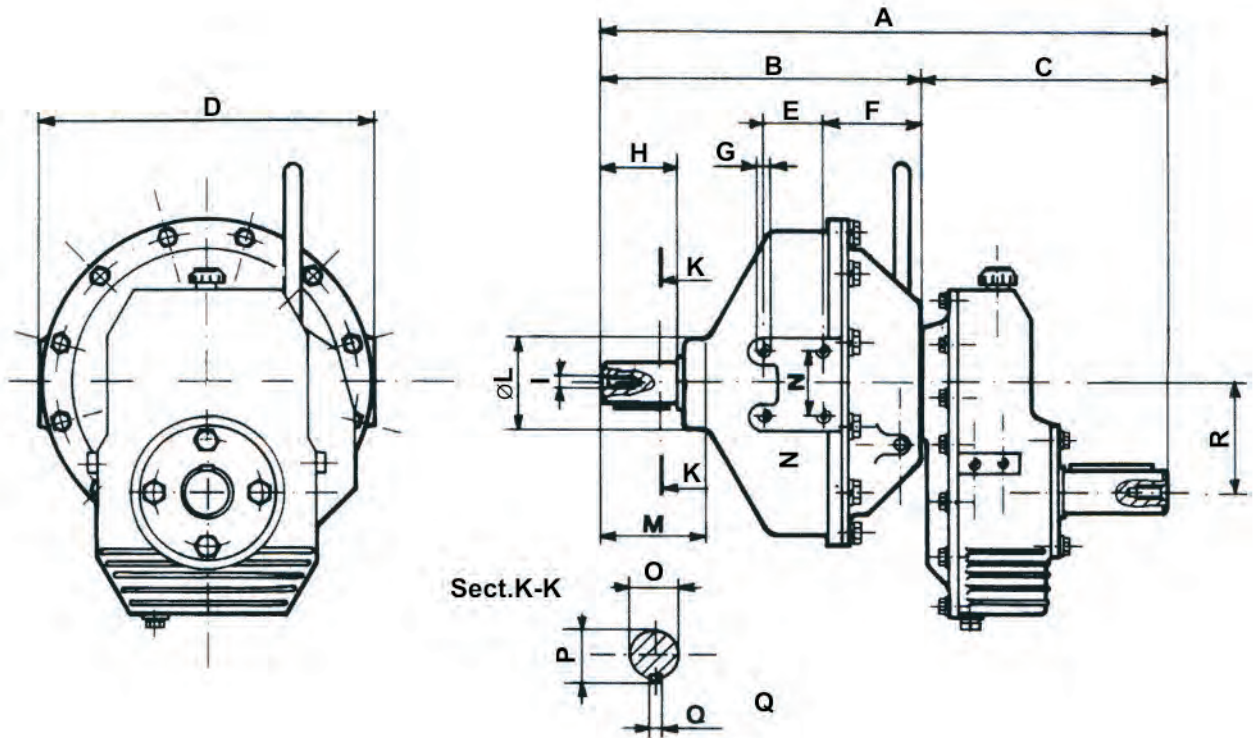

TYPE	A	B	C	D	E	F	G	H	I	L	M	N	O	P	Q	R
RM 20...BDS 112	526	369	157	404	70	105	M 10	90	M 14	140	45	80	50	54	14	67,5
RM 45...BDS 118	570	369	201	404	70	105	M 10	90	M 14	140	45	80	50	54	14	88,5
RM 70...BDS 130	627	403	224	404	70	139	M 10	90	M 14	140	45	80	50	54	14	121,5
RM 100...BDS 145	695	403	292	404	70	139	M 10	90	M 14	140	45	80	50	54	14	135
RM 120...BDS 145	743	403	340	404	70	139	M 10	90	M 14	140	45	80	50	54	14	160
RM 120...BDS 290	776	436	340	404	70	172	M 10	90	M 14	140	45	80	50	54	14	160
RM 150...BDS 290	838	436	402	404	70	172	M 10	90	M 14	140	45	80	50	54	14	189
RM 150...BDS 2200	1027	630	397	*	*	*	*	135	M 20	*	*	*	80	87	24	189

## ORDER CODE

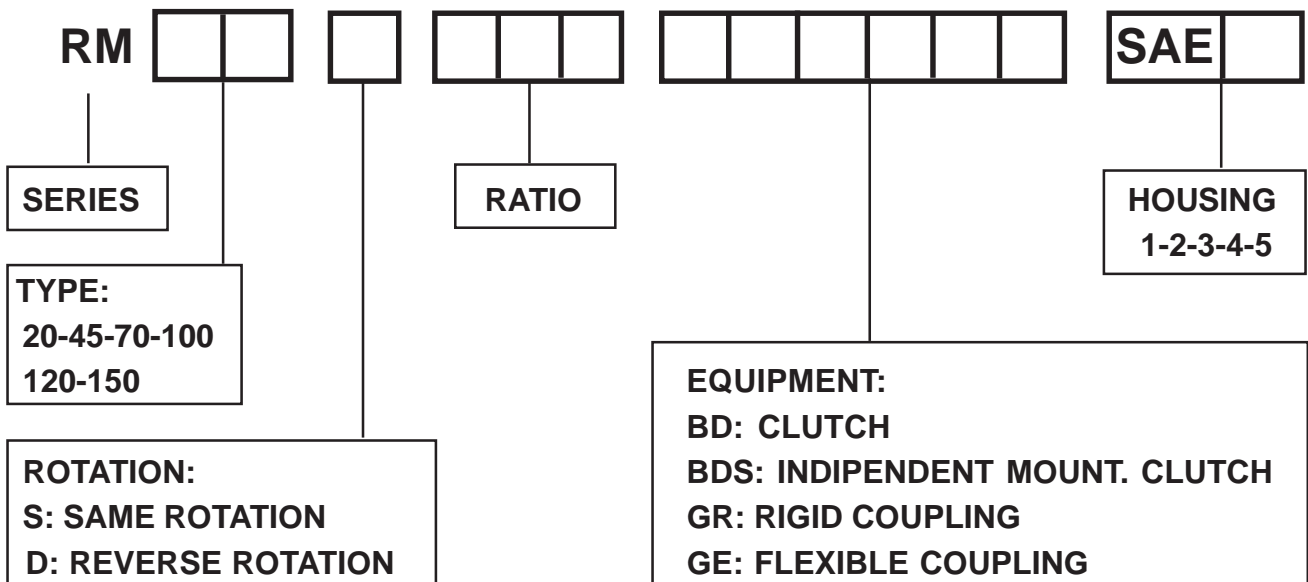

## RM... BDS SPEED REDUCING (INCREASING) GEARBOXES

Allowable side-pull loads on the output shaft

$$F = \frac{1910 \times kW}{n \times D} \times f \times f_1$$

F = Radial Load (dN)

kW = Input Power (kW)

n = Output shaft speed (n/min.)

D = Pulley Pitch diameter (m)

f = 1,0 - Load factor for chain or gear drive

2,5 - Load factor for V belts

3,5 - Load factor for flat belts

f<sub>1</sub> = 2 - Load factor only for reciprocating compressor or severe shock drives

The resulting value of F must to be lower or equal to that quoted on the table, according to the X distance.

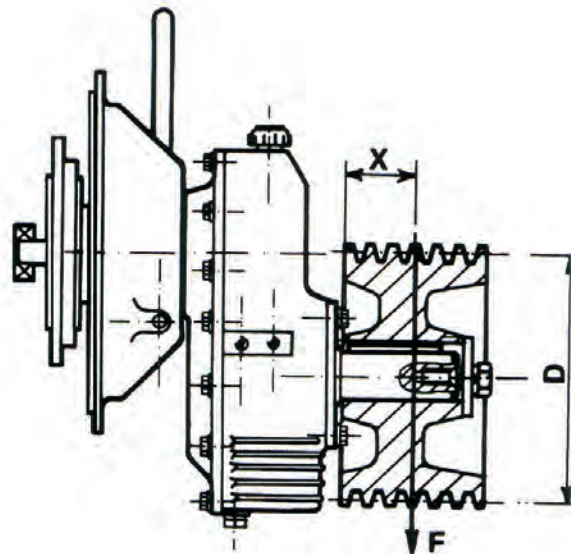

TYPE	SPEED n/min.	DISTANCE (X) mm.						
		30	40	50	60	80	100	150
		Radial Load (F) dN						
RM 20	1000	400	380	330	280	220	-	-
	2500	330	280	240	200	160	-	-
RM 45	1000	-	500	450	390	300	250	-
	2500	-	380	350	290	230	190	-
RM 70	1000	-	1050	900	780	650	530	-
	2500	-	800	700	600	500	410	-
RM 100	1000	-	1200	1100	1000	830	700	530
	2500	-	850	720	650	540	470	350
RM 120	1000	-	-	1600	1400	1150	970	750
	2500	-	-	1250	1100	900	790	570
RM 150	1000	-	-	1900	1700	1420	1200	900
	2500	-	-	1750	1580	1300	1100	820

# MECHANICAL POWER TAKE-OFF



## TECHNICAL FEATURES

The power take-off series "BD" may be coupled directly to Diesel engines with SAE flanges.

They can be used for a variety of industrial applications where there is a need to disengage movement from the engine to the driven unit, such as the drives of compressor, fans, pumps.

The mechanical controlled dry-disc clutch is equipped with a housing and supported by a shaft.

"BD" series range consists of single-disc clutch of 6½" - 7½" - 8" - 10" - 11½", double-disc clutch of 11½" - 14" and triple-disc clutch of 11½" - 14" and 18".

"BD" series power take off covers a power range between 15 and 700 kW.

## SELECTION

Selection of the clutch should be made considering the following issues:

- type of engine
- type of driven equipment
- number of engagement per hour
- absorbed power **P** (kW) by the driven unit and relevant speed **n** (n / min.)
- maximum rotation speed

The selection has to be made comparing maximum torque value that may be transmitted by the clutch, indicated with **T** in the catalogue and maximum torque value absorbed by the driven unit **Ta** multiplied by service factor **S** (see table below).

$$T_a \text{ (Nm)} = \frac{P \text{ (kW)}}{n \text{ (n/min)}} \times 9550$$

$$T_a \text{ (Nm)} \times S < T \text{ (Nm)}$$

Driven Equipment	Engine			
	Diesel 1-2 Cylinders Engine	Diesel 3-4 Cylinders Engine	Diesel 6 Cylinders Engine	Electric, Turbine
	Service factor S			
<b>Low WR2 equipment and torque demand curve similar to centrifugal pumps.</b> <b>Mechanism operate one or more hours before disconnecting.</b> centrifugal pump ventilator blowers/fans hydraulic pump generators cooling circuit pump firefighting pump	1,1	1,25	1,3	1,4
<b>Medium/low WR2 equipment and with low frequency of torque demand peaks.</b> <b>Clutch engaged max. 5 times each hour.</b> 4 cylinder compressor marine equipment excavator backhoe loaders	1,2	1,5	1,6	2,0
<b>Medium/high WR2 equipment.</b> <b>The clutch must engaged within 3 seconds.</b> <b>Clutch engaged max. 10 times each hour.</b> 2 cylinder compressors mills concrete mixers wood chippers	1,6	2,1	2,3	2,7
<b>High WR2 equipment and/or with high frequency of torque demand peaks and/or clutch engaged more than 10 times each hour.</b> <b>The clutch must engaged within 4 seconds.</b> Single cylinder compressors Crushers or impact load machines	2,2	2,8	3,1	3,6



## BD MECHANICAL CLUTCHES

### Installation Drawing - Technical Specifications

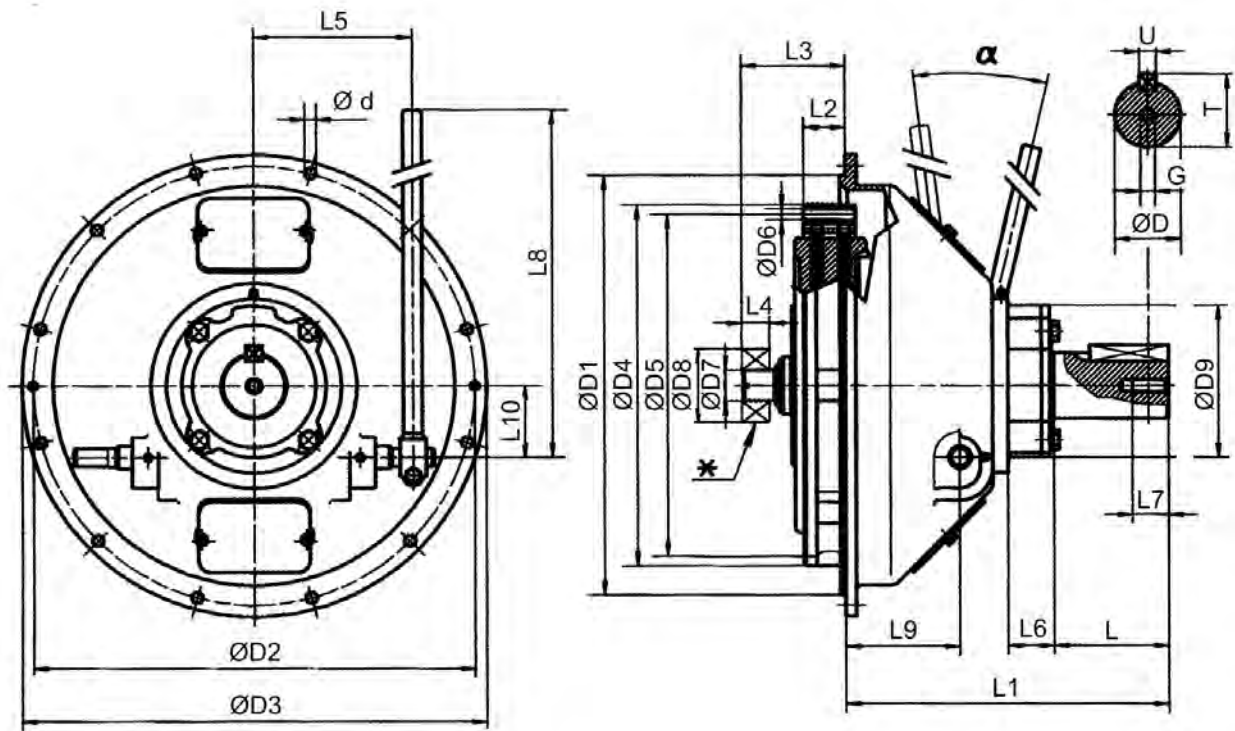

Model	Housing Size SAE	Max torque T(Nm)	Max speed n/min.	SAE Clutch	D4 mm	D5 mm	D6 n° x ø	Moment of inertia J (Kgm <sup>2</sup> )	Engag. torque M (Nm)	Weight Kg
BD 110/15	5	170	3500	6 - 1/2"	215,9	200	6x8,5	0,050	70	21
	4	170	3500	6 - 1/2"	215,9	200	6x8,5	0,050	70	22
BD 112/16	4	200	3500	7 - 1/2"	241,3	222,3	8x8,5	0,070	90	24
BD 112/16	4	200	3500	8"	263,5	244,5	6x10,5	0,080	90	24
	3	200	3500	8"	263,5	244,5	6x10,5	0,080	90	25
BD 118/24	4	240	3500	8"	263,5	244,5	6x10,5	0,090	110	29
	3	240	3500	8"	263,5	244,5	6x10,5	0,090	110	31
BD 130/50	4	330	3100	10"	314,3	295,3	8x11	0,140	220	44
	3	330	3100	10"	314,3	295,3	8x11	0,140	220	47
BD 145/75	4	450	3100	11 - 1/2"	352,4	333,4	8x10,5	0,260	220	48
	3	450	3100	11 - 1/2"	352,4	333,4	8x10,5	0,260	220	52
BD 290/150	3	880	2900	11 - 1/2"	352,4	333,4	8x10,5	0,450	220	68
	2	880	2900	11 - 1/2"	352,4	333,4	8x10,5	0,450	220	70
	1	880	2900	11 - 1/2"	352,4	333,4	8x10,5	0,450	220	75
BD 290/150 R	3	880	2900	11 - 1/2"	352,4	333,4	8x10,5	0,480	220	77
	2	880	2900	11 - 1/2"	352,4	333,4	8x10,5	0,480	220	79
	1	880	2900	11 - 1/2"	352,4	333,4	8x10,5	0,480	220	84
BD 390	3	1320	2900	11 - 1/2"	352,4	333,4	8x10,5	0,790	220	95
	2	1320	2900	11 - 1/2"	352,4	333,4	8x10,5	0,790	220	98
BD 2200	1	1960	2400	14"	466,7	438,2	8x13	1,820	400	156
BD 2200 R	1	1960	2400	14"	466,7	438,2	8x13	1,880	400	170
BD 3300	1	2940	2400	14"	466,7	438,2	8x13	2,550	500	170
BD 3300 R	1	2940	2400	14"	466,7	438,2	8x13	2,610	500	193
BD 3500	0	4150	2000	18"	571,5	542,9	6x17	6,120	600	420

## BD MECHANICAL CLUTCHES

### Installation Drawing

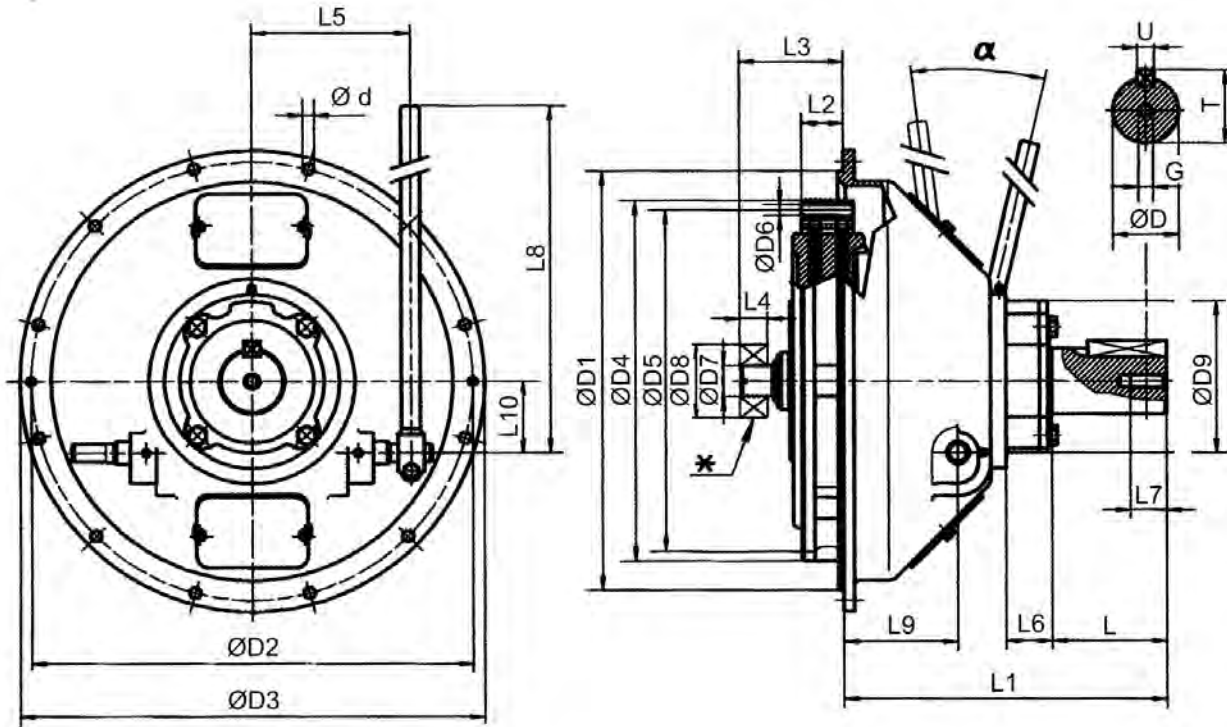

\* Pilot bearing upon your request

Housing Size SAE	D1	D2	D3	d n° x Ø
5	314.3	333.4	355	8x10.5
4	362	381	403	12x10.5
3	409.6	428.6	451	12x10.6
2	447.7	466.7	489	12x10.7
1	511.2	530.2	552	12x12
0	647.7	679.5	711	16x13.5

Model	SAE Clutch	L1 mm	Shaft					L2 mm	L3 mm	L4 mm	L5 mm	L6 mm	L7 mm	L8 mm	L9 mm	L10 mm	D7 mm	D8 mm	D9 mm	α
			L mm	D mm	T mm	U mm	G mm													
BD 110 / 15	6 ½"	212,5	80	36,51	41,3	9,52	M 10	30,2	71,4	18	148	12	25	400	68,5	70	25	52	96	18°
BD 110 / 15	7 ½"	212,5	80	36,51	41,3	9,52	M 10	30,2	71,4	18	148	12	25	400	68,5	70	25	52	96	18°
BD 112 / 16	7 ½"	212,5	80	36,51	41,3	9,52	M 10	30,2	71,4	18	148	12	25	400	68,5	70	25	52	96	18°
BD 112 / 16	8"	184	80	36,51	41,3	9,52	M 10	62	100	24	148	12	25	400	40	70	25	62	96	18°
BD 118 / 24	8"	221	100	44,45	50,8	12,70	M 10	62	100	24	148	29	28	400	40	70	25	62	138	18°
BD 130 / 50	10"	297	140	57,15	65,1	15,87	M 10	53,8	100	27	160	33	30	400	78	70	30	72	122	18°
BD 145 / 75	11 ½"	334	165	57,15	65,1	15,87	M 14	39,6	100	27	155	45	30	400	78	70	30	72	170	20°
BD 290 / 150 SAE 3	11 ½"	367	165	63,50	71,4	15,87	M 14	39,6	100	27	155	45	35	400	MI	70	30	72	170	20°
BD 290 / 150 SAE 2-1	11 ½"	367	165	63,50	71,4	15,87	M 14	39,6	100	27	200	45	35	600	107	80	30	72	170	20°
BD 290 / 150 R SAE 3	11 ½"	461	150	63,50	71,4	15,87	M 14	39,6	100	27	155	134	35	400	MI	70	30	72	154	20°
BD 290 / 150 R SAE 2-1	11 ½"	461	150	63,50	71,4	15,87	M 14	39,6	100	27	200	134	35	600	107	80	30	72	154	20°
BD 390 SAE 3	11 ½"	488	150	63,50	71,4	15,87	M 14	39,6	100	27	155	134	35	400	138	70	30	72	154	20°
BD 390 SAE 2	11 ½"	488	150	63,50	71,4	15,87	M 14	39,6	100	27	200	134	35	600	138	80	30	72	154	20°
BD 2200	14"	467	140	88,90	100	22,22	M 20	25,4	100	31	215	77	40	600	179	114	35	80	220	15°
BD 2200 R	14"	571	140	88,90	100	22,22	M 20	25,4	100	31	215	181	40	600	179	114	35	80	220	15°
BD 3300	14"	495	140	88,90	100	22,22	M 20	25,4	100	31	215	77	40	600	207	114	35	80	220	15°
BD 3300 R	14"	600	140	88,90	100	22,22	M 20	25,4	100	31	215	181	40	600	207	114	35	80	220	15°
BD 3500	18"	663	200	114,30	127	25,4	M 24	15,7	100	29	305	105	60	600	265	145	55	120	290	15°



## BD - BDS MECHANICAL CLUTCHES

Allowable side-pull loads on the output shaft

$$F = \frac{1910 \times kW}{n \times D} \times f \times f_1$$

F = Radial Load (dN)

kW = Input Power (kW)

n = Output shaft speed (n/min.)

D = Pulley Pitch diameter (m)

f = 1,0 - Load factor for chain or gear drive

2,5 - Load factor for V belts

3,5 - Load factor for flat belts

f<sub>1</sub> = 2 - Load factor only for reciprocating compressor or severe shock drives

The resulting value of F must to be lower or equal to that quoted on the table, according to the X distance.

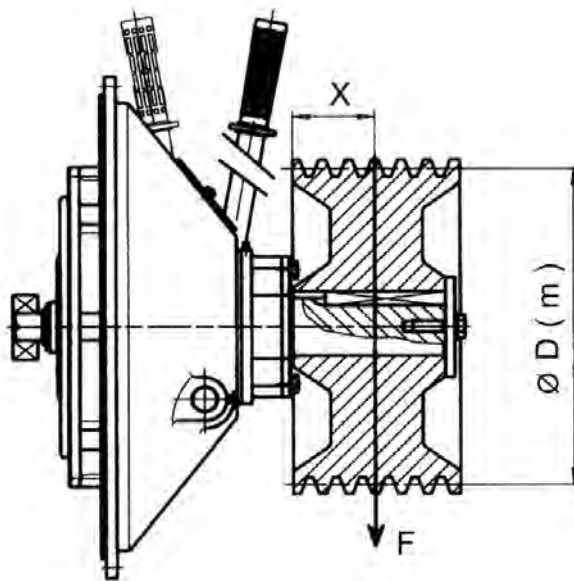

Model	X (mm) - Distance					
	30	50	80	100	120	140
<b>BD 110 / 15</b>	370	280	.	.	.	.
<b>BD 112 / 16</b>	370	280	.	.	.	.
<b>BD 118 / 24</b>	560	430	335	.	.	.
<b>BD 130 / 50</b>	930	600	430	-	-	.
<b>BD 145 / 75</b>	1800	1200	750	650	-	-
<b>BD 290 / 150</b>	1800	1200	750	650	-	-
<b>BD 390</b>	2500	2000	1500	1250	.	-
<b>BD 2200</b>	-	2150	1600	1350	1200	.
<b>BD 3300</b>	-	2150	1600	1350	1200	-
<b>BD 3500</b>	-	2800	2700	2650	2600	2500

## BDS INDIPENDENT MOUNTING MECHANICAL CLUTCHES

Installation Drawing - Technical Specifications

**BDS 112 - 118 - 130 - 145 - 290 - 2200 - 3300**

### TECHNICAL SPECIFICATIONS

Model	Max. torque T(Nm)	Max. speed n / min.	Weight Kg	Moment of inertia j (Kgm <sup>2</sup> )
BDS 112/16	200	3500	52	0,1175
BDS 118/24	240	3500	57	0,1375
BDS 130/50	330	3100	75	0,2875
BDS 145/75	450	3100	83	0,4375
BDS 290/150	880	2900	106	0,6750
BDS 2200	1960	2400	264	3,0000
BDS 3300	2940	2400	288	3,3750

**BDS 112 - 118 - 130 - 145 - 290**

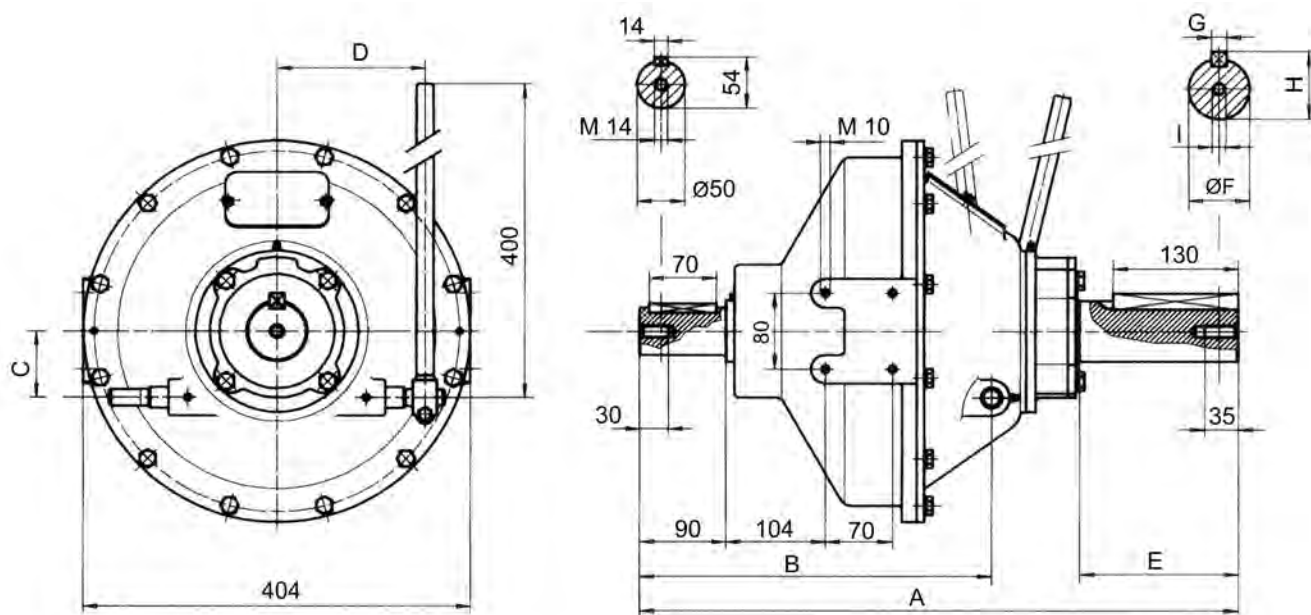

**BDS 112 - 118 - 130 - 145 - 290**

### DIMENSIONS

Model	A mm	B mm	C mm	D mm	E mm	F mm	G mm	H mm	I mm
BDS 112	474	330	70	148	80	36,51	9,52	41,3	M 10
BDS 118	511	330	70	148	100	44,45	12,70	50,8	M 10
BDS 130	587	368	70	160	140	57,15	15,87	65,1	M 10
BDS 145	623	368	70	155	165	57,15	15,87	65,1	M 14
BDS 290	656	401	70	155	165	63,50	15,87	71,4	M 14

## BDS INDEPENDENT MOUNTING MECHANICAL CLUTCHES

Installation Drawing - Technical Specifications

### BDS 2200 - 3300

### DIMENSIONS

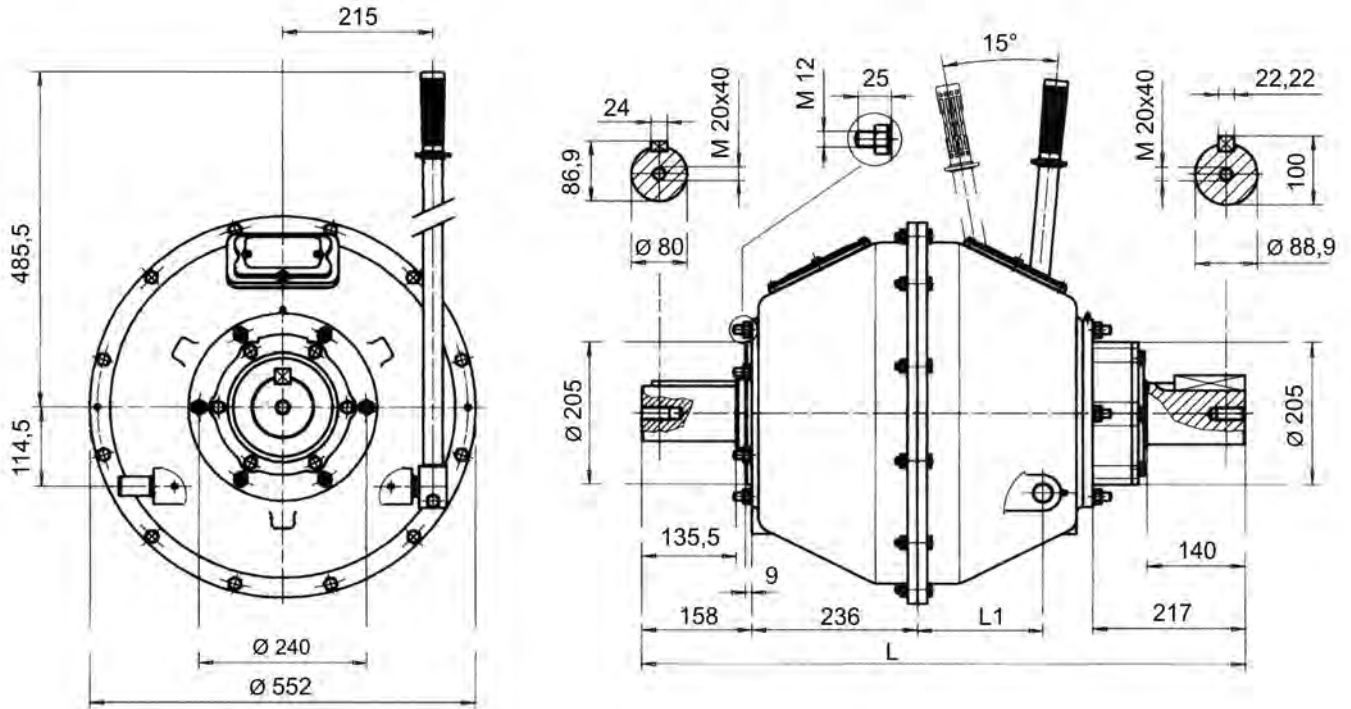

Model	L mm	L1 mm
BDS 2200	862	179
BDS 3300	890	207

## BD MECHANICAL CLUTCHES

Flange thickness

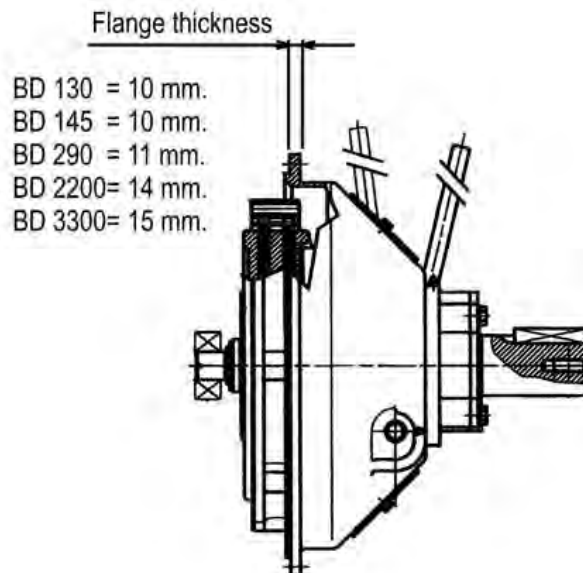

## BDP - BDSP MECHANICAL CLUTCHES

Single plate and double plate 11-1/2" Pto's can be supplied with suitable output for direct mounting of hydrostatic pumps. Torque and technical characteristics are the same as correspondent "BD" and "BDS" models.

### BDP 145 - 290

#### Installation Drawing - Technical Specifications

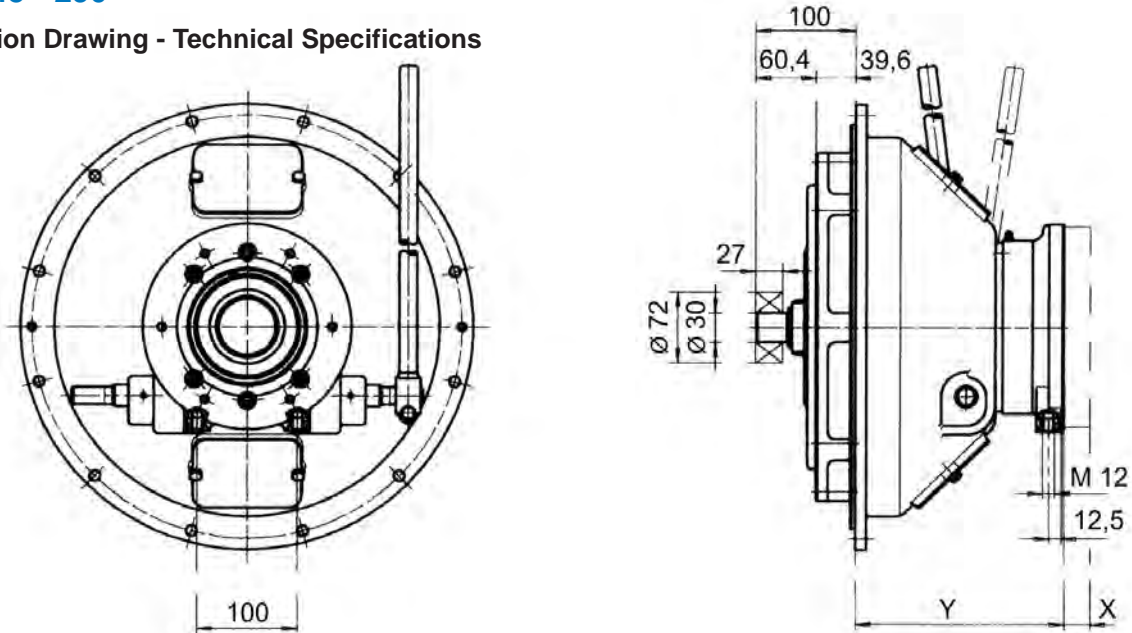

Model	SAE Housing size	Flywheel size	Max. torque Nm	Max speed n / min.	Y mm
BDP 145	3-4	11-1/2"	450	3100	174
BDP 290	1-2-3	11-1/2"	880	2900	207

Pump flange	X mm
SAE B	20
SAE C	28

### BDSP 145 - 290

#### Installation Drawing - Technical Specifications

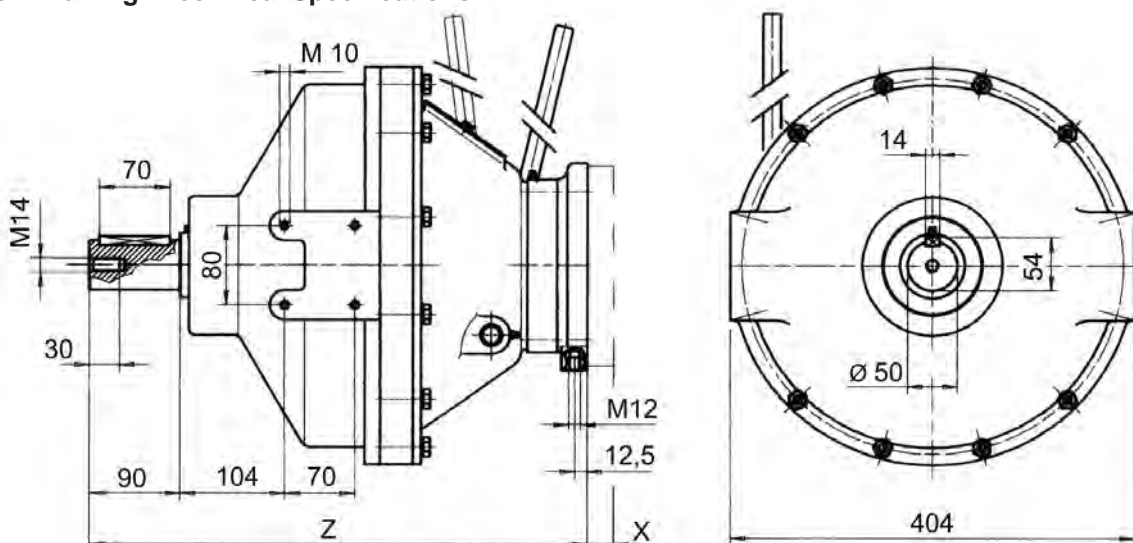

Model	Max. torque - Nm	Max speed n / min	Z mm
BDSP 145	450	3100	463
BDSP 290	880	2900	496

Pump flange	X mm
SAE B	20
SAE C	28

# HYDRAULIC POWER TAKE-OFF

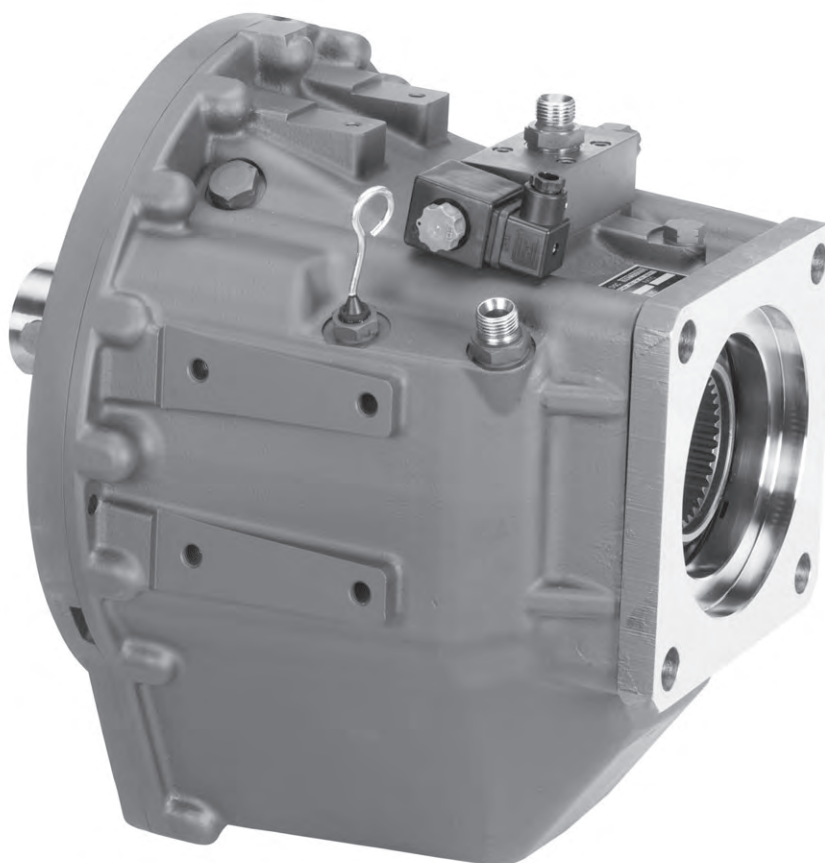



## HYDRAULIC POWER TAKE-OFF - PFI 60

### SPECIFICATIONS

Multiple disc clutch in oil bath, hydraulically operated with 24V electric selector for remote control.

**Versions:** input cylindric shaft; output cylindric shaft or female splined shaft for hydraulic pump connection.  
SAE 3-2-1 housing or free standing mounting possibilities.

**Input rotation:** right or left hand (to be specified with order).

**Cooling:** oil must be cooled by an external heat exchanger.

### TECHNICAL DATA

- Max. Torque     **600 Nm**
- Max. Speed     **3200 n/min.**
- Weight           **80 kg.**

P.TO. selection is to be made multiplying the net input power by the service factor:

- 1,0 for centrifugal pumps
- 1,3 for hydraulic pumps
- 1,5 for direct winch drivers
- 2,0 for crushers

### POWER CURVE

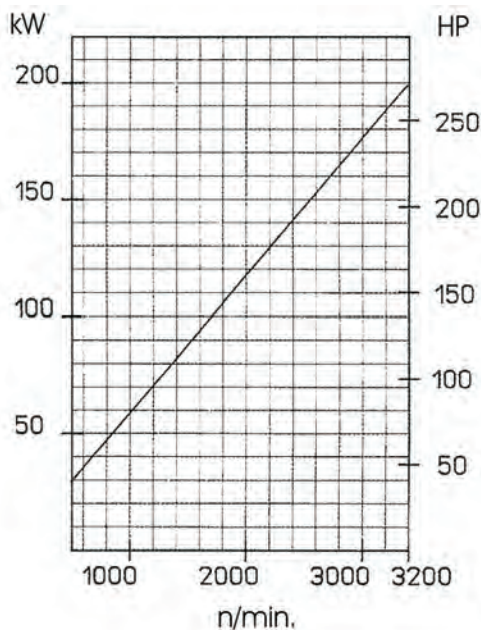





## HYDRAULIC POWER TAKE-OFF PFI 120

### SPECIFICATIONS

Multiple disc clutch in oil bath, hydraulically operated with mechanical or 12V or 24V electric selector for remote control.

**Versions:** input cylindric shaft; output cylindric shaft or female splined shaft for hydraulic pump connection. SAE 3-2-1 housing or free standing mounting possibilities.

**Input rotation:** right or left hand (to be specified with order).

**Cooling:** oil must be cooled by an external heat exchanger.

### TECHNICAL DATA

- **Max. Torque**      **1200 Nm**
- **Max. Speed**     **3000 n/min.**
- **Weight**            **100 kg.**

P.TO. selection is to be made multiplying the net input power by the service factor:

- 1,0 for centrifugal pumps
- 1,3 for hydraulic pumps
- 1,5 for direct winch drivers
- 2,0 for crushers.

The resulting power is to be below the line on the graph.

### POWER CURVE

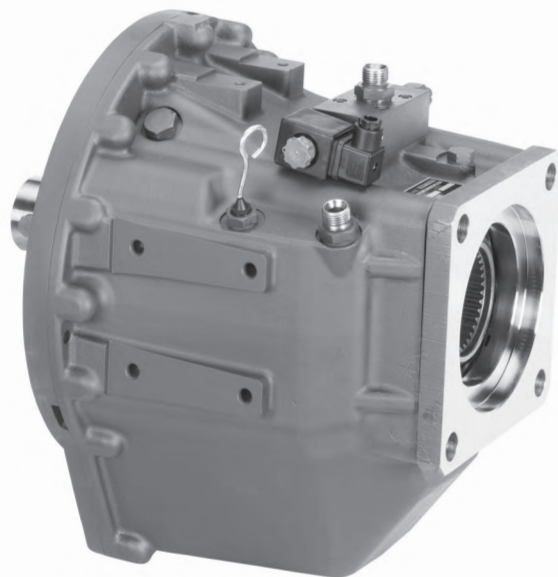
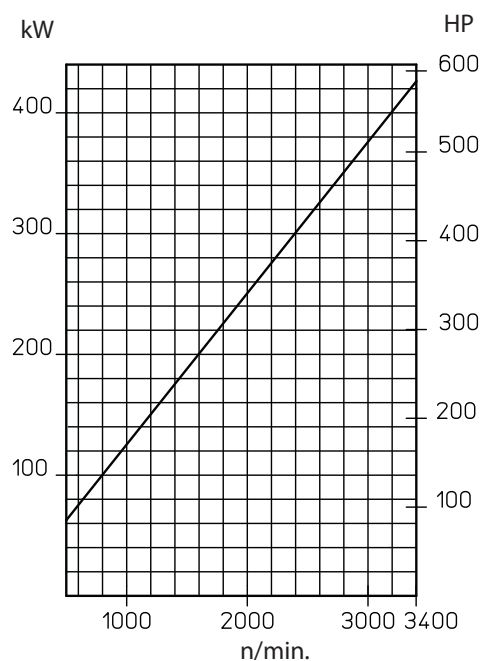

## HYDRAULIC POWER TAKE-OFF - PFI 120

### INSTALLATION DRAWING

#### PFI 120

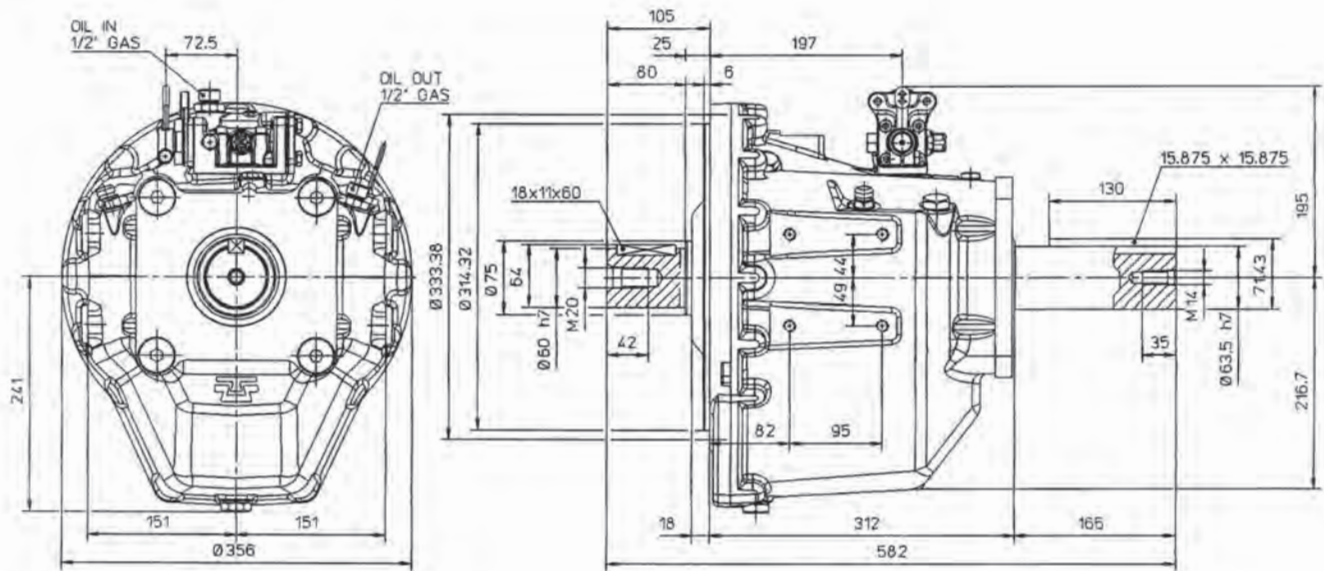

#### PFI 120 P

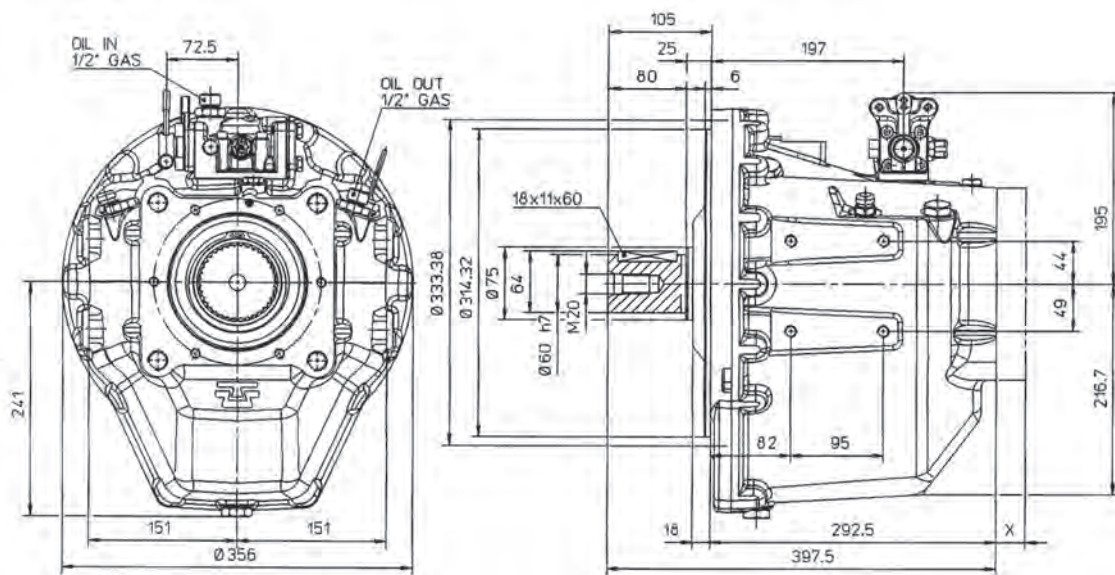

# PUMP DRIVE ADAPTORS



## BELL HOUSINGS AND COUPLINGS FOR HYDRAULIC PUMPS

### INTRODUCTION

Thanks to the availability of bell housings and couplings, we can offer a complete kit to couple a wide range of hydraulic pumps having SAE, ISO or CETOP flanging to Diesel engines equipped with flywheel-housing and flywheel according to SAE specification.

The couplings are made of an external part of aluminium alloy and internal part of steel with intermediate rubber elements.

The connection to the pump shaft is allowed by means of one or more splined hubs.

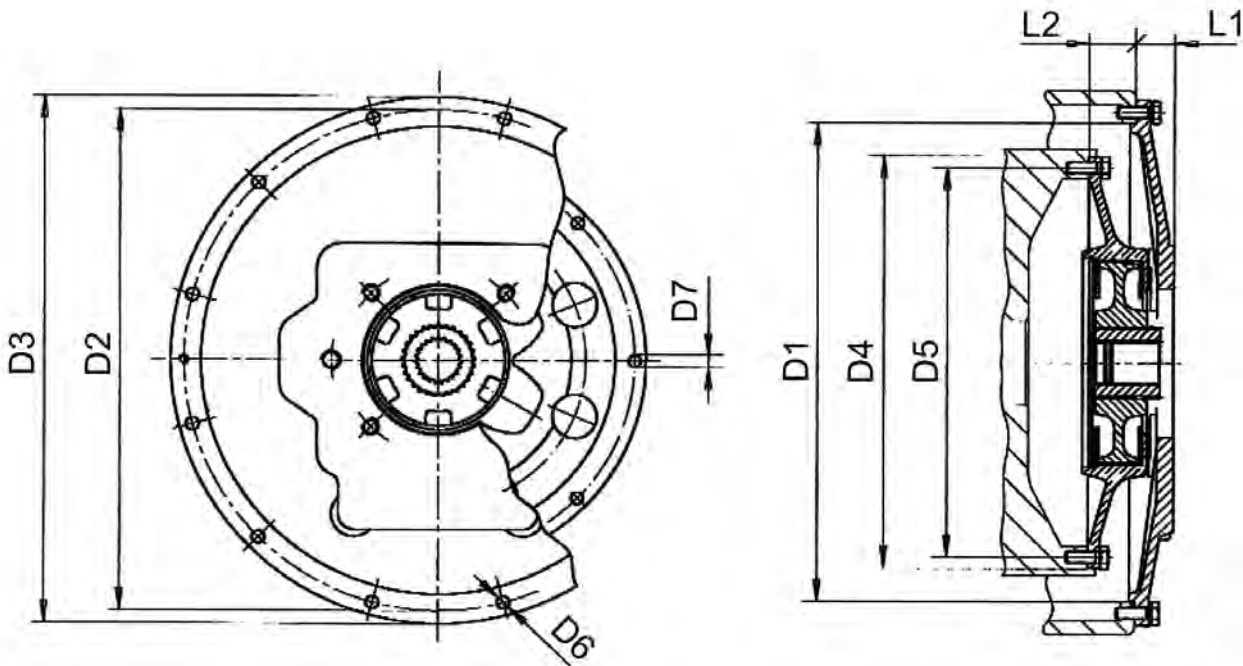

Coupling					Max. torque Nm		Max. speed n / min.	Mom. Inertia J Kg <sup>m</sup> <sup>2</sup>
SAE	D4	D5	L2	D7	cont.	int.		
6- 1/2"	215.19	200	30.2	9	300	400	4000	0.0043
7-1/2"	241.3	222.3	30.2	9	300	400	4000	0.0098
8"	263.5	244.5	61.9	11	300	400	4000	0.0135
10"	314.3	295.3	53.8	11	300	400	4000	0.0215
11-1/2"	352.4	333.4	39.6	11	650	850	3500	0.0517

Bell Housing								
SAE size	D1	D2	D3	D6	L1			
SAE 1	511.2	530.2	552	12	50	/	/	/
SAE 2	447.7	466.7	489	11	50	/	/	/
SAE 3	409.6	428.6	451	11	33	50	13.5	
SAE 4	361.9	381	403	11	33	50	12.5	
SAE 5	314.3	333.4	356	11	35.5	50	13.5	



**FLYWHEEL SIDE ADAPTORS**

**SAE 1 - 11 1/2 "**

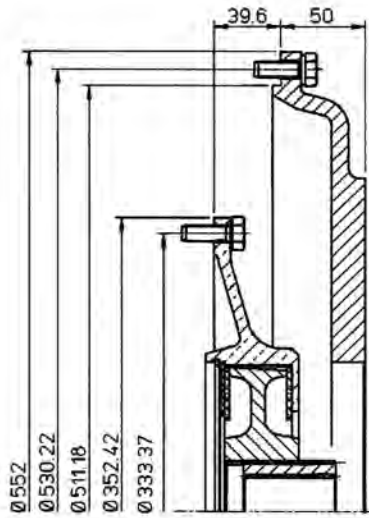

**SAE 2 - 11 1/2 "**

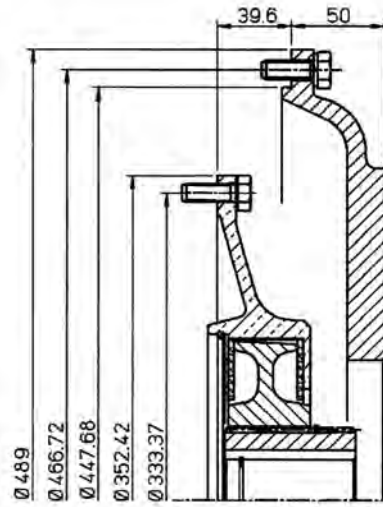

**SAE 3 - 10" long**

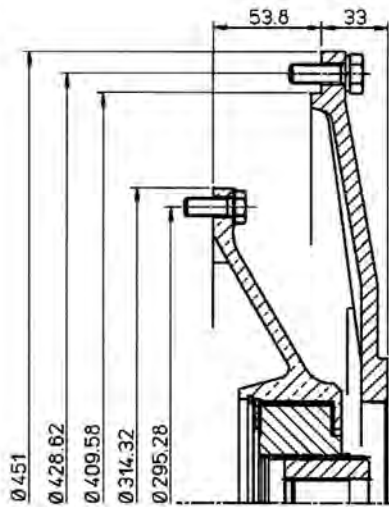

**SAE 3 - 10" short**

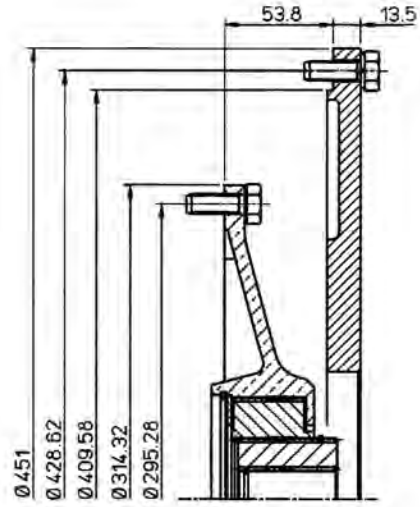

**SAE 3 - 11 1/2" long**

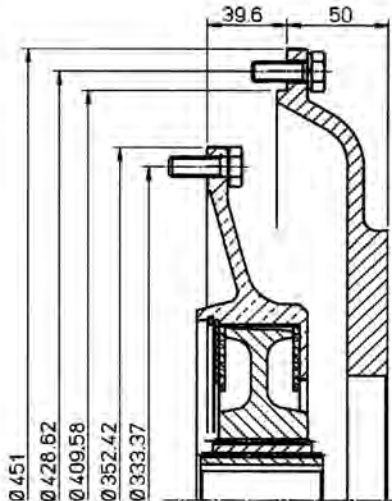

**SAE 3 - 11 1/2" short**

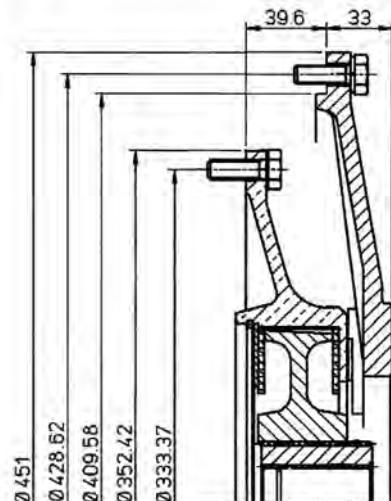

## FLYWHEEL SIDE ADAPTORS

### SAE 4 - 6 1/2 "

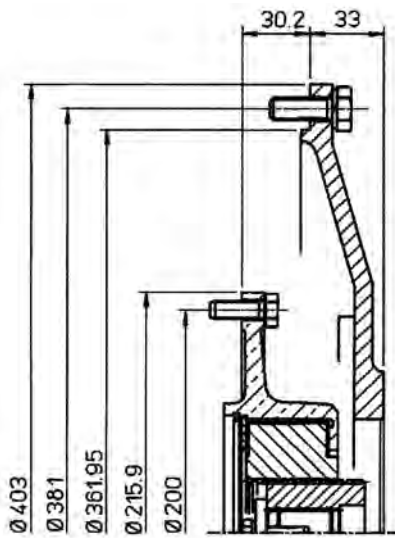

### SAE 4 - 7 1/2 "

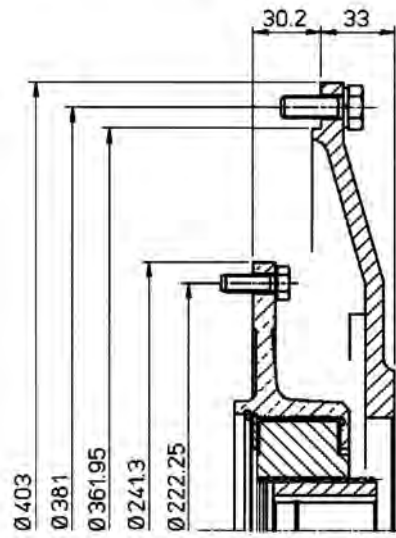

### SAE 4 - 8"

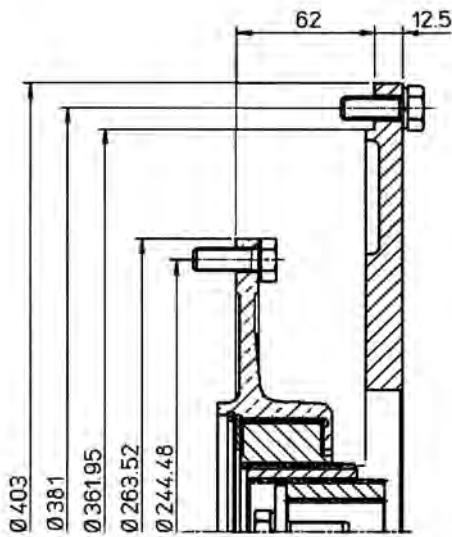

### SAE 4 - 10" long

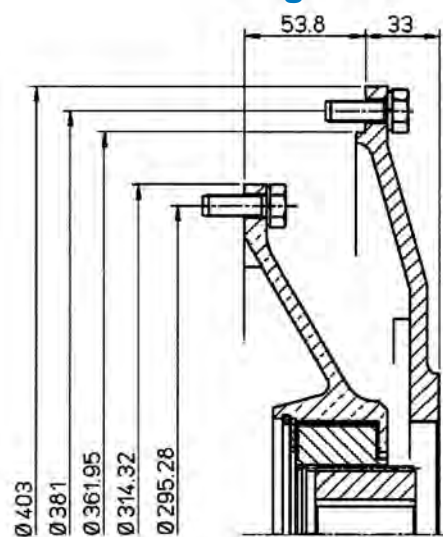

### SAE 4 - 10" short

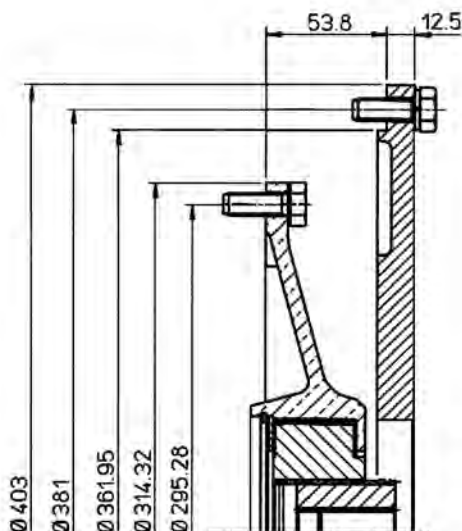

### SAE 4 - 11 1/2"

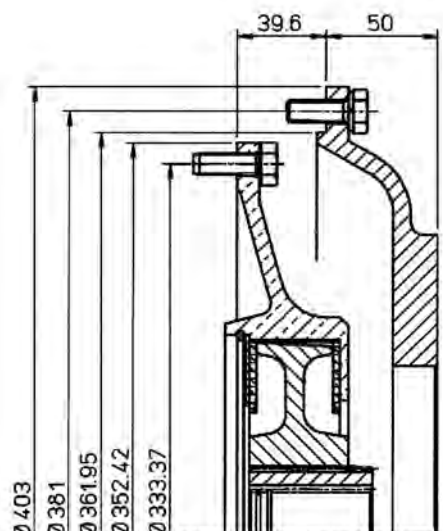

## FLYWHEEL SIDE ADAPTORS

### SAE 5 - 6 1/2 "

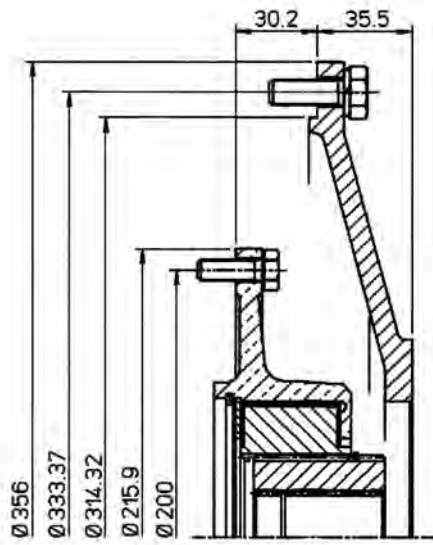

### SAE 5 - 7 1/2 "

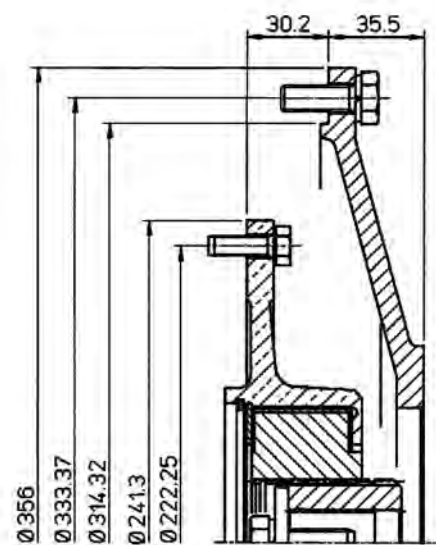

### SAE 5 - 8"

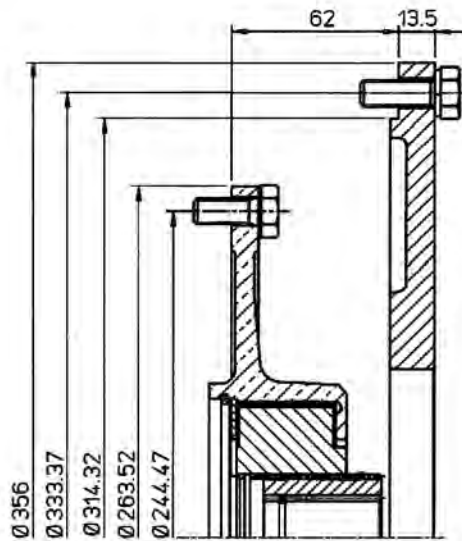

### SAE 4 - Kubota V 3300

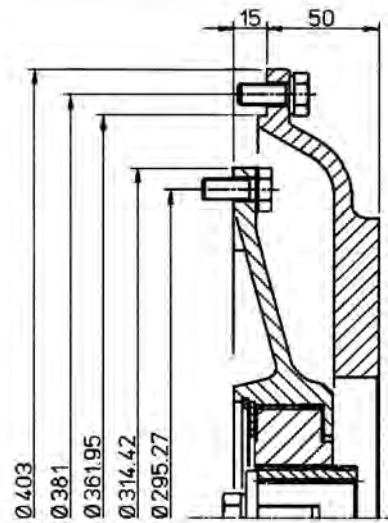

### Lombardini 5LD

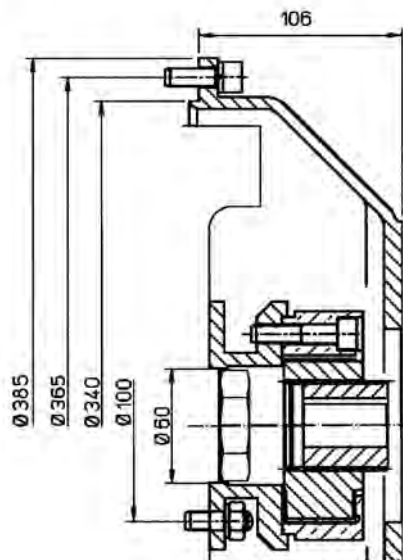

### SAE 5 - Hatz2/3/4 L30-40

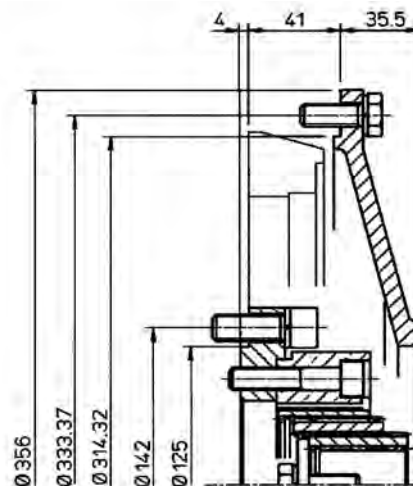



## FLYWHEEL SIDE ADAPTORS

**SAE 4 - Yanmar 94-98**

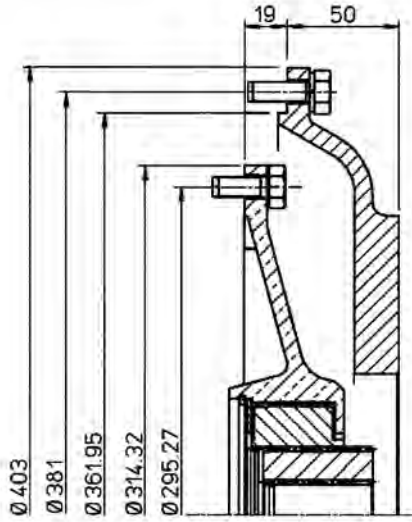

**SAE 5 - Yanmar 3TNE 68-74-82  
Yanmar 4 TNE 84-88**

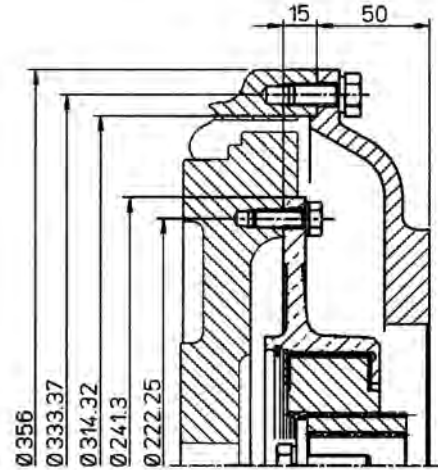

**SAE 4 - VM SUN**

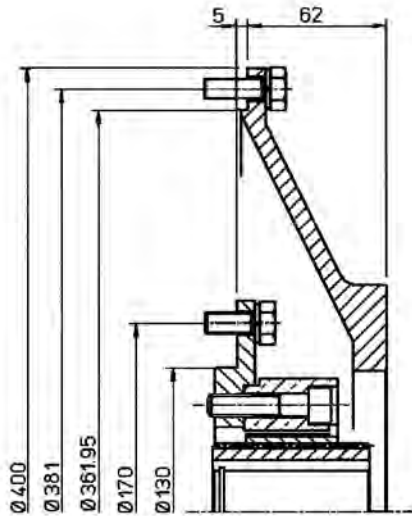

**SAE 4 - VM D700**

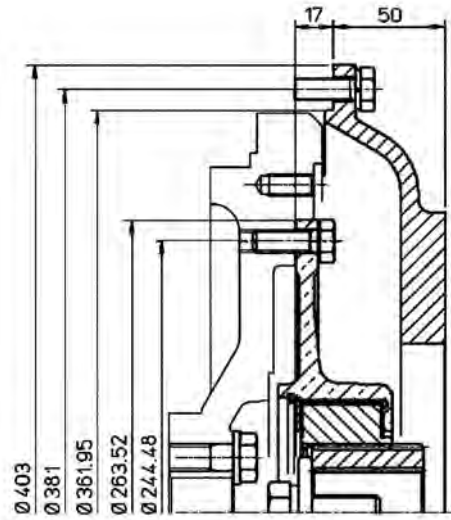

## ISO FLANGES

### Hatz 2G40

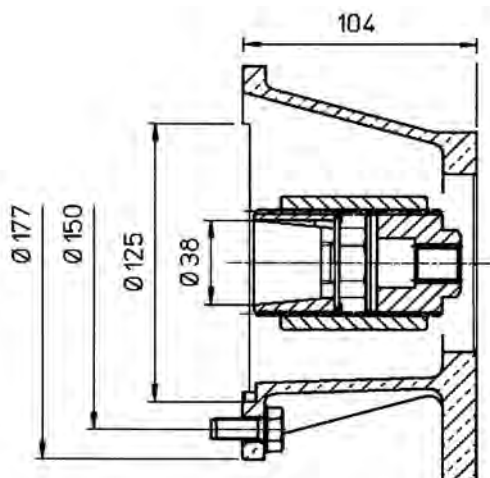

### Lombardini 3LD

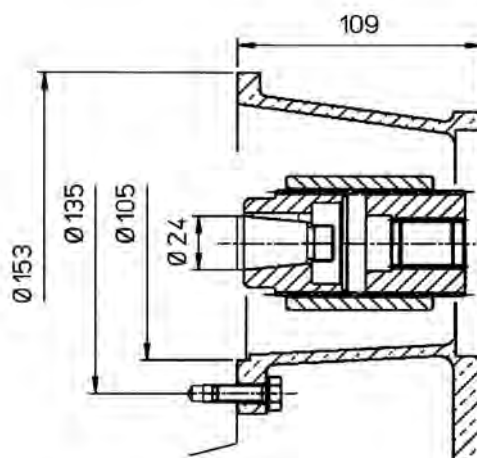

### Lombardini 4LD

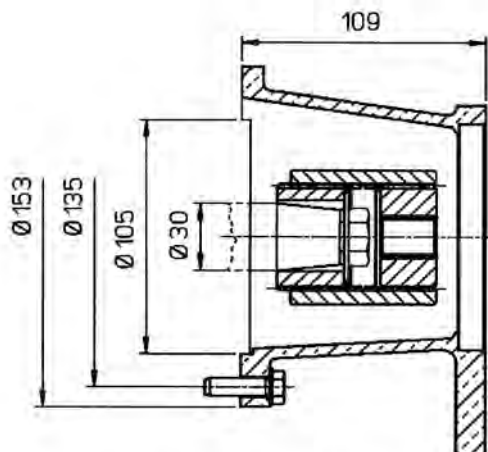

### Lombardini 6LD

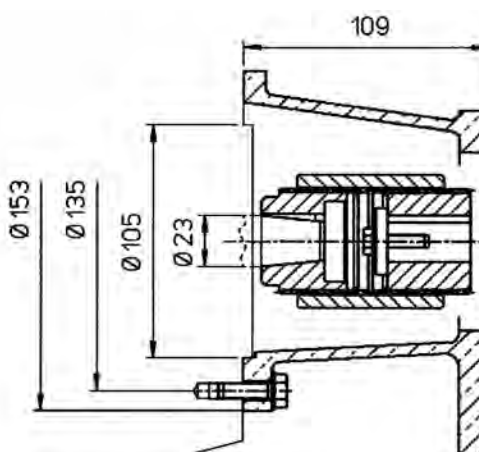

### Lombardini 7LD

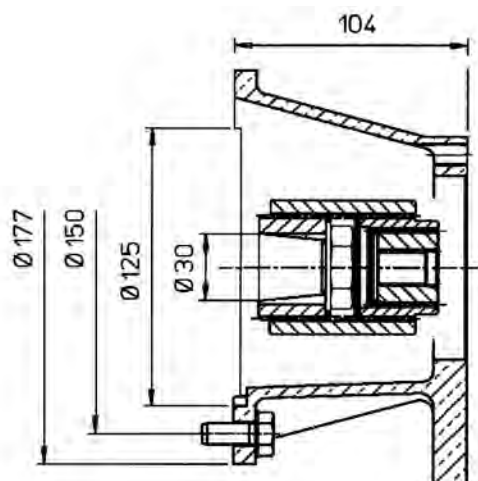

### Lombardini 15LD

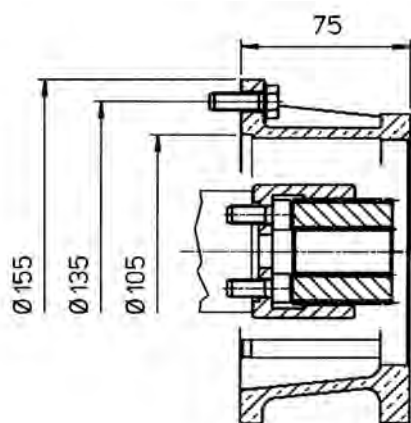

## FRONT MOUNTING ADAPTORS

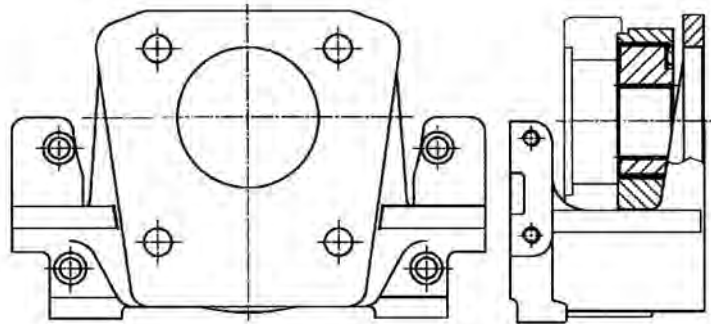

**Deutz F5/6L-912 F5/6L-913**

**Same 1000 Series**

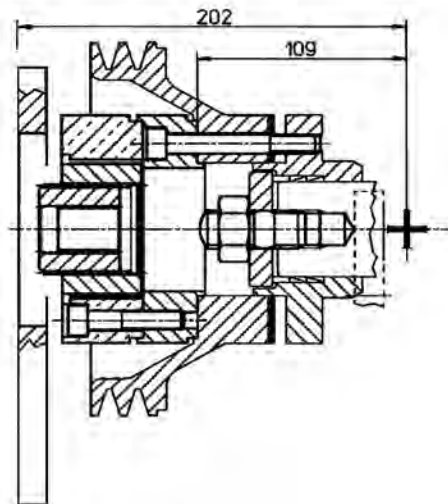
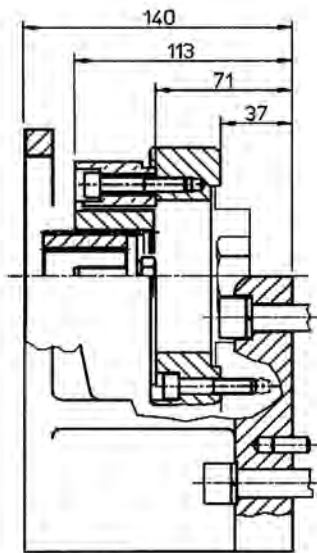

**VM SUN Series**

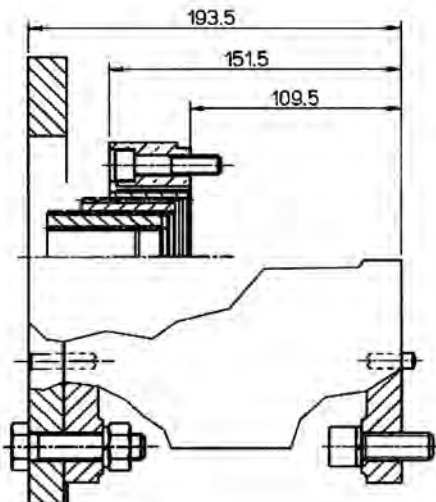

As HANSA-TMP has a very extensive range of products and some products have a variety of applications, the information supplied may often only apply to specific situations.

If the catalogue does not supply all the information required, please contact HANSA-TMP.

In order to provide a comprehensive reply to queries we may require specific data regarding the proposed application.

Whilst every reasonable endeavour has been made to ensure accuracy, this publication cannot be considered to represent part of any contract, whether expressed or implied.

HANSA-TMP reserves the right to amend specifications at their discretion.



---

---

Dutch Hydraulic Consultants BV	Tel. : +31-(0)6-83695868
Achterweg ZZ 8	Mail : <a href="mailto:info@dhc-hydraulic.nl">info@dhc-hydraulic.nl</a>
3216 AB Abbenbroek	Web : <a href="http://www.dhc-hydraulic.nl">www.dhc-hydraulic.nl</a>
Nederland	